

CAREL

μChiller

Controller for Chiller / Heat Pump



USER MANUAL

LEGGI E CONSERVA
QUESTE ISTRUZIONI

READ AND SAVE
THESE INSTRUCTIONS



NO POWER
& SIGNAL
CABLES
TOGETHER

READ CAREFULLY IN THE TEXT!

μChiller

+0300053EN - ENG

Up to date version available on

www.carel.com

GENERAL WARNINGS



CAREL bases the development of its products on decades of experience in HVAC/R, on continuous investments in technological innovations to products, procedures and strict quality processes with in-circuit and functional testing on 100% of its products, and on the most innovative production technology available on the market. CAREL and its subsidiaries/affiliates nonetheless cannot guarantee that all the aspects of the product and the software included with the product respond to the requirements of the final application, despite the product being developed according to start-of-the-art techniques. The customer (manufacturer, developer or installer of the final equipment) accepts all liability and risk relating to the configuration of the product in order to reach the expected results in relation to the specific final installation and/or equipment. CAREL may, based on specific agreements, act as a consultant for the successful commissioning of the final unit/application, however in no case does it accept liability for the correct operation of the final equipment/system. The CAREL product is a state-of-the-art product, whose operation is specified in the technical documentation supplied with the product or can be downloaded, even prior to purchase, from the website www.carel.com. Each CAREL product, in relation to its advanced level of technology, requires setup/configuration/programming/commissioning to be able to operate in the best possible way for the specific application. Failure to complete such operations, which are required/indicated in the user manual, may cause the final product to malfunction; CAREL accepts no liability in such cases. Only qualified personnel may install or carry out technical service on the product.

The customer must only use the product in the manner described in the documentation relating to the product. In addition to observing any further warnings described in this manual, the following warnings must be heeded for all CAREL products:

- prevent the electronic circuits from getting wet. Rain, humidity and all types of liquids or condensate contain corrosive minerals that may damage the electronic circuits. In any case, the product should be used or stored in environments that comply with the temperature and humidity limits specified in the manual;
- do not install the device in particularly hot environments. Too high temperatures may reduce the life of electronic devices, damage them and deform or melt the plastic parts. In any case, the product should be used or stored in environments that comply with the temperature and humidity limits specified in the manual;
- do not attempt to open the device in any way other than described in the manual.
- do not drop, hit or shake the device, as the internal circuits and mechanisms may be irreparably damaged.
- do not use corrosive chemicals, solvents or aggressive detergents to clean the device.
- do not use the product for applications other than those specified in the technical manual.

All of the above suggestions likewise apply to the controllers, serial cards, programming keys or any other accessory in the CAREL product portfolio. CAREL adopts a policy of continual development. Consequently, CAREL reserves the right to make changes and improvements to any product described in this document without prior warning. The technical specifications shown in the manual may be changed without prior warning. The liability of CAREL in relation to its products is specified in the CAREL general contract conditions, available on the website www.carel.com and/or by specific agreements with customers; specifically, to the extent where allowed by applicable legislation, in no case will CAREL, its employees or subsidiaries/affiliates be liable for any lost earnings or sales, losses of data and information, costs of replacement goods or services, damage to things or people, downtime or any direct, indirect, incidental, actual, punitive, exemplary, special or consequential damage of any kind whatsoever, whether contractual, extra-contractual or due to negligence, or any other liabilities deriving from the installation, use or impossibility to use the product, even if CAREL or its subsidiaries/affiliates are warned of the possibility of such damage.

DISPOSAL



Fig. 1



Fig. 2

INFORMATION FOR USERS ON THE CORRECT HANDLING OF WASTE ELECTRICAL AND ELECTRONIC EQUIPMENT (WEEE)

The product is made up of metal parts and plastic parts. In reference to European Union directive 2002/96/EC issued on 27 January 2003 and related national legislation, please note that:

- WEEE cannot be disposed of as municipal waste and such waste must be collected and disposed of separately;
- the public or private waste collection systems defined by local legislation must be used. In addition, the equipment can be returned to the distributor at the end of its working life when buying new equipment;
- the equipment may contain hazardous substances: the improper use or incorrect disposal of such may have negative effects on human health and on the environment;
- the symbol (crossed-out wheeled bin) shown on the product or on the packaging and on the instruction sheet indicates that the equipment has been introduced onto the market after 13 August 2005 and that it must be disposed of separately;
- in the event of illegal disposal of electrical and electronic waste, the penalties are specified by local waste disposal legislation.

Warranty on materials: 2 years (from production date, excluding consumables).

Approval: the quality and safety of CAREL S.p.A. products are guaranteed by the ISO 9001 certified design and production system.

IMPORTANT

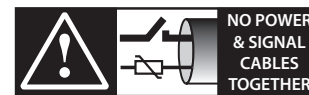

READ CAREFULLY IN THE TEXT!

Separate as much as possible the probe and digital input cables from cables to inductive loads and power cables, so as to avoid possible electromagnetic disturbance. Never run power cables (including the electrical panel cables) and signal cables in the same conduits.

Key to the symbols:



Important: to bring critical issues to the attention of those using the product.



Note: to focus attention on important topics; in particular the practical application of the various product functions.



Important: This product is to be integrated and/or incorporated into the final apparatus or equipment. Verification of conformity to the laws and technical standards in force in the country where the final apparatus or equipment will be operated is the manufacturer's responsibility. Before delivering the product, Carel has already completed the checks and tests required by the relevant European directives and harmonised standards, using a typical test setup, which however cannot be considered as representing all possible conditions of the final installation.

Index

1. Introduction.....	7	6. Parameter table.....	83
1.1 Main functions.....	7	6.1 System.....	83
1.2 Models.....	8	6.2 Compressor.....	84
1.3 Accessories.....	8	6.3 BLDC and Inverter.....	85
2. Installation.....	12	6.4 Valve.....	86
2.1 Warnings.....	12	6.5 Source.....	86
2.2 Panel version.....	12	6.6 Input/output configuration.....	88
2.3 DIN rail version.....	13	6.7 mCH2 parameters (Legacy models only).....	88
2.4 Electrical installation.....	13	6.8 BMS port.....	89
2.5 Probe/digital input connection.....	14	6.9 Password.....	89
2.6 Connection to user terminals.....	15	6.10 Dashboard values.....	89
2.7 Positioning inside the panel.....	16	6.11 Settings.....	90
2.8 Electrical installation.....	17	7. Supervisor table.....	91
2.9 Connecting serial ports with two circuits.....	17	7.1 Coil Status.....	91
2.10 Connection to Power+ (for BLDC).....	18	7.2 Input Status.....	92
2.11 Positioning of probes/ components.....	19	7.3 Holding Register.....	93
2.12 Input/output configuration.....	19	7.4 Input Register.....	97
2.13 Functional diagrams.....	22	8. Alarms and signals.....	99
3. Initial configuration.....	36	8.1 Types of alarms.....	99
3.1 APPLICA app.....	36	8.2 Alarm list.....	100
3.2 Configuration procedure.....	36	9. Technical specifications.....	102
3.3 Unit set-up parameter list.....	40	9.1 Connector/cable table.....	104
3.4 Applica Desktop.....	42	10. Release notes.....	104
3.5 Configuration procedure with Applica Desktop - Legacy Model.....	43		
4. User interface.....	46		
4.1 Introduction.....	46		
4.2 User terminal.....	46		
4.3 Standard display.....	47		
5. Functions.....	51		
5.1 Temperature control.....	51		
5.2 User pumps.....	53		
5.3 Frost protection control.....	55		
5.4 Compressor rotation.....	58		
5.5 Compressor management.....	60		
5.6 BLDC compressor protectors.....	62		
5.7 BLDC comp. alarm prevention.....	63		
5.8 Compressor alarms.....	65		
5.9 Power+ Speed drive.....	65		
5.10 Expansion valve driver.....	66		
5.11 Control of the expansion valve.....	66		
5.12 Source pump.....	66		
5.13 Source fans.....	67		
5.14 Free cooling.....	70		
5.15 Types of free cooling.....	70		
5.16 Free cooling.....	73		
5.17 Defrost.....	74		
5.18 4-way valve management.....	78		
5.19 Manual device management.....	78		
5.20 Air/air unit management (Legacy model only).....	79		
5.21 Automatic heater management for water units (Legacy model only).....	80		
5.22 Condensing unit management.....	81		
5.23 Automatic changeover (Legacy model only).....	81		

1. INTRODUCTION

µChiller is the Carel solution for complete management of air/water and water/water chillers and heat pumps, and condensing units. The solution also allows the field replacement of µchiller2 and µchiller2 SE with the new product (hereinafter called the Legacy model). The maximum configuration manages 2 compressors per circuit (*), up to a maximum of 2 circuits (using an expansion card for circuit 2). The distinctive element of µChiller is complete control of high- efficiency units through integrated management of electronic expansion valves (ExV) and brushless BLDC compressors, thus ensuring greater compressor protection and reliability and a high-efficiency unit. The user terminal allows wireless connectivity with mobile devices and is built-in on the panel mounted models, or sold separately on DIN rail mounted models. CAREL's "APPLICA" app, available on Google Play for the Android operating system, makes it easier to configure parameters and commission the unit in the field.

(*): 2 On/Off compressors or 1 BLDC compressor + 1 On/Off compressor.

1.1 Main functions

Ref.	Description
Main features	Up to two circuits and 2 + 2 compressors
	Compressors in tandem configuration with possible BLDC compressor (*)
	Air/water chiller or heat pump (A/W)
	Water/water chiller or heat pump (W/W)
	Cooling-only condensing unit
	Reverse-cycle condensing unit
	Air/air unit, cooling only (Legacy models only)
	Air/air unit, reverse-cycle (Legacy models only)
	1 evaporator per unit
	Air-cooled condenser with separate/shared air circuit for A/W units
Hardware	Water-cooled condenser with single circuit for W/W units
	Panel mounted model: management of ON-OFF compressors
	DIN rail mounted model: management of ON-OFF compressors
	DIN rail mounted model, enhanced: management of ON-OFF compressors
User interface	DIN rail mounted model, high efficiency: management of BLDC compressors
	7-segment, 2-row LED display, optional pGDx graphic display, communication via APPLICA app (compatible with NFC and BTLE) for mobile devices
Temperature control	PID at start-up
	PID in operation
	Set point compensation on outdoor temperature
Compressor rotation	FIFO or timed
Compressor management	Specific BLDC compressors (see list on KSA - µChiller section)
	Generic scroll compressors
Oil management with BLDC	Oil recovery function (extended operation at part load)
	Oil equalisation (tandem with BLDC compressor)
Circuit destabilisation	Forced compressor rotation (extended operation at part load)
ExV driver	Built-in valve driver on enhanced and high efficiency models
	External driver management via FieldBus port (all versions)
Programming with time bands	Unit ON-OFF or 2nd set point (1 time band per day)
	"Noise reduction" function for condenser fans (1 time band per day)
User pumps	1/2 pumps (2 pumps only with 2 circuits)
	Rotation by time or with pump overload alarm
	Cyclical activation during standby
Water-cooled condenser	1 common pump for both circuits
Air-cooled condenser	Independent fans on each circuit or common to both circuits
	Fan modulation based on condensing temperature (On/Off fan control via CAREL CONVONOFF0 module)
	Optimised start-up to quickly bring the compressor(s) to steady operation
	Fan anti-block protection (harsh climate)
Defrost	Simultaneous
	Separate
	Independent
	Using only the fans
Prevent	Defrost interval managed based on outside temperature ("sliding defrost")
	Prevention of scroll compressor operating limits in relation to condensing and evaporation temperature
Alarms	Evaporator frost prevention
	Total management of the BLDC compressor envelope limits
	Management of automatic and manual reset according to alarm severity (see the chapter on Alarms)
Connectivity/supervision	Alarm log (up to 20 events): alarm and reset date and time recorded
	RS485 serial port
	Modbus RTU
	Baud rate up to 115200 bit/s
	Frame configurable by Parity (None, Even, Odd) and StopBits (1 or 2); Databits fixed at 8 bits.

Tab. 1.a

(*) the configuration envisaged requires the capacity of the ON/OFF compressor to be equal to 60% of the capacity of the BLDC compressor (at maximum speed).

1.2 Models

P/N	Assembly	Connectivity	Compresso management:	Notes	Electronic expansion valve management
UCHBP00000190	panel	NFC	On/Off	Standard version	bipolar: with EVD Evolution driver
UCHBP00000200	panel	NFC, Bluetooth (BLE)	On/Off	Standard version	bipolar: with EVD Evolution driver
UCHBD00001230	DIN rail	-	On/Off	Standard version	bipolar: with EVD Evolution driver
UCHBDE00001150	DIN rail	-	On/Off	Enhanced version	unipolar: built-in; bipolar with external EVD Evolution driver
UCHBDH00001150	DIN rail	-	On/Off and BLDC	-	bipolar: with external EVD Evolution driver
UCHBE00001230: 2nd circuit expansion	DIN rail	-	On/Off and BLDC	-	unipolar: built-in; bipolar with external EVD Evolution driver
UCHBE00001150: 2nd circuit expansion	DIN rail	-	On/Off and BLDC	-	unipolar: built-in; bipolar: with external EVD Evolution driver
UCHBP000X0190	panel	NFC	On/Off	Legacy version	bipolar: with EVD Evolution driver
UCHBP000X0200	NFC, Bluetooth	NFC, Bluetooth	On/Off	Legacy version	bipolar: with EVD Evolution driver
UCHBP000X0230	DIN rail	-	On/Off	Legacy version	bipolar: with EVD Evolution driver

Tab. 1.b

1.3 Accessories

1.3.1 µChiller user terminal

For DIN rail mounted models (built-in on the panel model). The user terminal includes the display and keypad, comprising four buttons that, when pressed alone or combined with other buttons, access the operations available for the “User” and “Service” profiles (see the paragraph on “Commissioning”). Connectivity - NFC or NFC + Bluetooth (BLE) based on the model - allows interaction with mobile devices and simplifies unit commissioning (after having installed the CAREL “Applica” APP for the Android operating system, see chapters “Commissioning” and “User interface”). For assembly, see the technical leaflet +0500146IE.



Fig. 1.a

Code	Description
AX5000PD20A20	User terminal (NFC)
AX5000PD20A30	User terminal (NFC, Bluetooth BLE)
ACS00CB000020	Connection cable L=1.5 m
ACS00CB000010	Connection cable L=3 m

Tab. 1.c

1.3.2 pGDx Touch user terminal

The 4.3” pGDx graphic terminal is part of the touch screen family designed to make the user interface simple and intuitive. The electronic technology used and the 65K colour display enable management of high quality images and advanced features to ensure a high aesthetic standard. The touch screen display guarantees simple human-machine interaction, making it easier to browse between the various screens. See the technical leaflet +050001895.



Fig. 1.b

Code	Description
PGR04****B***	pGDx, 1 x RS485 port, 1 x 24 Vdc power connector, 1 optional keypad connector
PGR04****C***	pGDx, 1 x opto-isolated RS485 port, 1 x 24 Vdc power connector, 1 optional keypad connector, 1 Ethernet port

Tab. 1.d

1.3.3 EVD Evolution/EVD Evolution twin valve driver

The Enhanced and High Efficiency models have the driver built-into the controller, able to drive unipolar valves (up to Carel model E3V, with a cooling capacity less than 90-100kW); all versions can be connected to the external EVD Evolution driver to drive bipolar valves (with a higher cooling capacity).



Fig. 1.c

Part number Description

EVD0000T20	EVD evolution twin universal (RS485/Modbus)
EVD0000T21	EVD evolution twin universal, (RS485/Modbus) multiple pack of 10 pcs.
EVD0000T50	EVD evolution twin Carel valve (RS485/Modbus)
EVD0000T51	EVD evolution twin Carel valve, (RS485/Modbus) multiple pack of 10 pcs.

Tab. 1.e

1.3.4 Temperature sensors

NTC sensors for measuring the temperatures in the user circuit, the outdoor air or source, and the refrigeration circuit. NTC**HT sensors are recommended for discharge temperature measurement (with BLDC compressors in heat pump mode).



Fig. 1.d

Code	Type	Range
NTC060HF01	10 kΩ ±1% @25°C, IP67	-50 to 90°C strap-on
NTC060HP00	10 kΩ ±1% @25°C, IP67	-50 to 50 °C (105°C in air)
NTC060HT00	50 kΩ ±1% @25°C, IP67	-30 to 100°C RH95% in air (150°C in a dry environment)

Tab. 1.f

🔔 **Notice:** see manual +040010025 (ITA- ENG) /+040010026 (FRE- GER) for guidelines on installing the sensors on the unit.

1.3.5 Pressure sensors

These measure:

1. evaporation pressure in the circuit, used to control superheat, manage the evaporator frost protection function and the operating limits;
2. condensing pressure in the circuit, to control the condensing stage and manage the operating limits.

See the technical leaflet +050000488.



Fig. 1.e

Code	Type	Application	Range
SPKT0*13P*	0-5V	LP R407C, R290	-1 to 9.3 bars
SPKT0*43P*	0-5V	LP R410A, R32	0 to 17.3 bars
SPKT0*33P*	0-5V	HP R407C, R290	0 to 34.5 bars
SPKT0*B6P*	0-5V	HP R410A, R32	0 to 45 bars
SPKT0011C*	4-20mA	LP R407C, R290	0 to 10 bars
SPKT0041C*	4-20mA	LP R410A, R32	0 to 18.2 bars
SPKT0031C*	4-20mA	HP R407C, R290	0 to 30 bars
SPKT00B1C*	4-20mA	HP R410A, R32	0 to 44.8 bars
SPKC00*310	IP67 connection cable		L=2 to 12 m
SPKC00*311	IP67 connection cable - 50 pcs		L=0.65 to 1.3 m

Tab. 1.g

1.3.6 Unipolar valve (P/N E2V**FSAC*)



Fig. 1.f

Used with a compatible stator from the E2VSTA03**series. Unipolar electronic expansion valve, managed directly by the controller, which guarantees precise refrigerant flow even at low flow- rates. See the technical leaflet +050001680.

1.3.7 Ultracap module (EVD0000UC0)



Fig. 1.g

The Ultracap module EVD0000UC0 is an optional external backup module for the EVD Evolution driver that ensures the valves are closed in the event of a power failure. The module guarantees temporary power supply to one EVD Evolution driver (single or twin) only in the event of a power failure, for enough time to immediately close the connected electronic valves (one or two). It therefore also avoids the need to install a solenoid valve in the refrigeration circuit, or a backup coil kit.

1.3.8 Ultracap module for unipolar valve (EVD000HAC0)

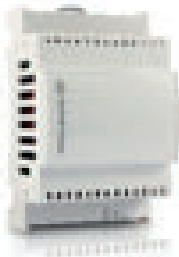

Fig. 1.h

The Ultracap module EVD000HAC0 is an optional device used with the μChiller models equipped with an integrated unipolar electronic valve driver. This external backup module closes the valve in the event of a power failure.

Part number	Description
EVD000HAC0	Ultracap module for HVAC ACU APPLICATIONS
ACS00CB002370	Ultracap module cable for unipolar valve 0,3 m

1.3.9 Cloudgate for tERA connection



Fig. 1.i

CloudGate is CAREL's new family of IoT gateways to enable monitoring and tERA platform services for HVAC/R systems with up to 10 units. Compact, standard installation inside an electrical panel and a local LED interface with immediate indication of communication status make Cloudgate easy to install in the field, without the need for experts in connectivity devices.

1.3.10 Connector kit



Fig. 1.j

Part number	Description
UCHCONP000	uChiller panel MOLEX/free connector kit
UCHCONP010	uChiller panel MOLEX/free connector and 100 cm cable kit
UCHCONP030	uChiller panel Molex/free connector and 300 cm cable kit
UCHCOND000	uChiller DIN MOLEX/free connector kit
UCHCOND010	uChiller DIN MOLEX/free connector and 100 cm cable kit
UCHCONPMC0	Adapter kit for MCH2

1.3.11 Cables for LED displays (DIN models only)

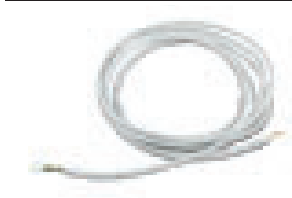

Fig. 1.k

Part number	Description
ACS00CB000010	Display cable AX JST/JST 3 M
ACS00CB000020	Display cable AX JST/JST 1.5 m
ACS00CB000012	Display cable AX JST/JST 3 m, multiple pack (10 pcs)
ACS00CB000022	Display cable AX JST/JST 1.5 m, multiple pack (10 pcs)

1.3.12 USB/RS485 converter (CVSTDUMOR0)



Fig. 1.l

Electronic device used to interface an RS485 network to a personal computer via the USB port. See the technical leaflet +050000590.

2. INSTALLATION

2.1 Warnings

▲ Important: avoid installing the controller in environments with the following characteristics:

- temperature and humidity that do not comply with the ambient operating conditions (see "Technical specifications");
- strong vibrations or knocks;
- exposure to water sprays or condensate;
- exposure to aggressive and polluting atmospheres (e.g.: sulphur and ammonia gases, saline mist, smoke) which may cause corrosion and/or oxidation;
- strong magnetic and/or radio frequency interference (thus avoid installation near transmitting antennae);
- exposure to direct sunlight and the elements in general;
- wide and rapid fluctuations in ambient temperature;
- exposure to dust (formation of corrosive patina with possible oxidation and reduction of insulation).

2.2 Panel version

2.2.1 Dimensions - mm (in)

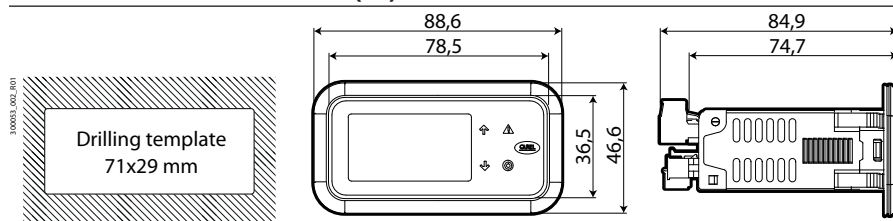

Fig. 2.a

2.2.2 Assembly

▲ Important: before carrying out any maintenance, disconnect the controller from the power supply by moving the main system switch to "off".

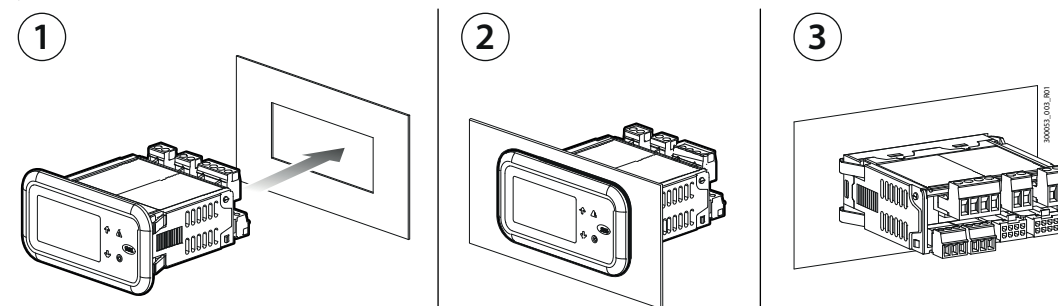

Fig. 2.b

1. Place the controller in the opening, pressing lightly on the side anchoring tabs.
2. Then press on the front until fully inserted (the side tabs will bend, and the catches will attach the controller to the panel).

▲ Important: IP65 front protection is guaranteed only if the following conditions are met:

- maximum deviation of the rectangular opening from flat surface: ≤ 0.5 mm;
- thickness of the electrical panel sheet metal: 0.8-2 mm;
- maximum roughness of the surface where the gasket is applied: ≤ 120 μm .

ⓘ Notice: the thickness of the sheet metal (or material) used to make the electrical panel must be adequate to ensure safe and stable mounting of the product.

2.2.3 Removal

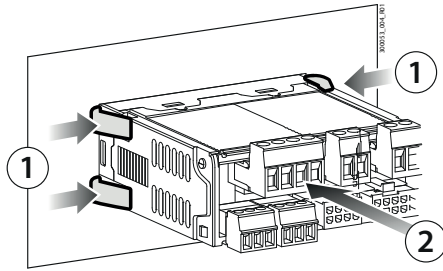

Fig. 2.c

Open the electrical panel from the rear and press the anchoring tabs and then the controller to remove it.

1. Gently press the side anchoring tabs on the controller;
2. Exert slight pressure on the controller until it is removed.

⚠ Important: the operation does not require the use of a screwdriver or other tools.

2.3 DIN rail version

2.3.1 Dimensions - mm(in)

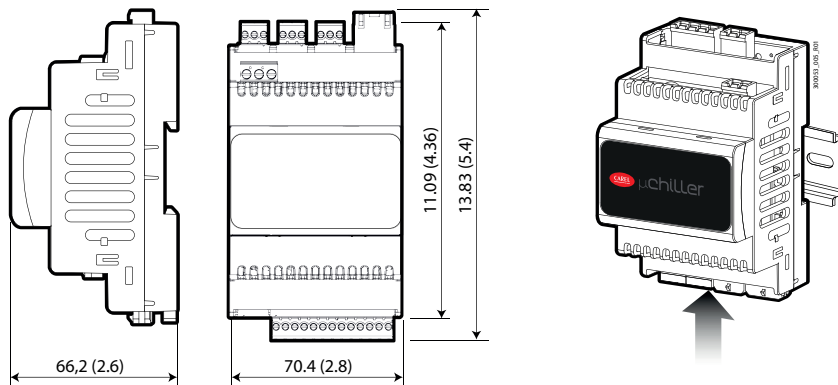

Fig. 2.d

Apply slight pressure to the controller resting on the DIN rail until the rear tab clicks into place.

2.3.2 Removal

Use a screwdriver as a lever in the hole to lift and release the tab. The tab is held in the locked position by return springs.

2.4 Electrical installation

⚠ Important: before carrying out any maintenance, disconnect the controller from the power supply by moving the main system switch to "off".

2.4.1 Description of the terminals

Panel model

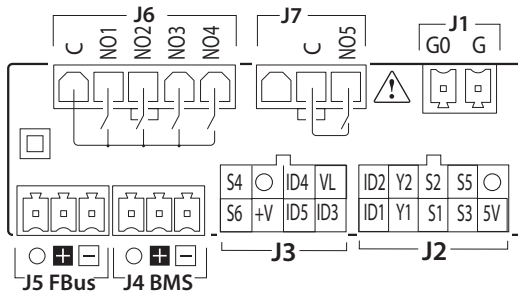
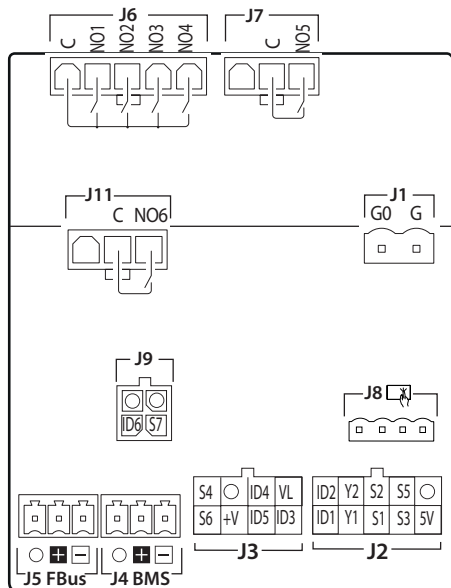

Fig. 2.e

DIN rail model

Basic



Enhanced/ High Efficiency

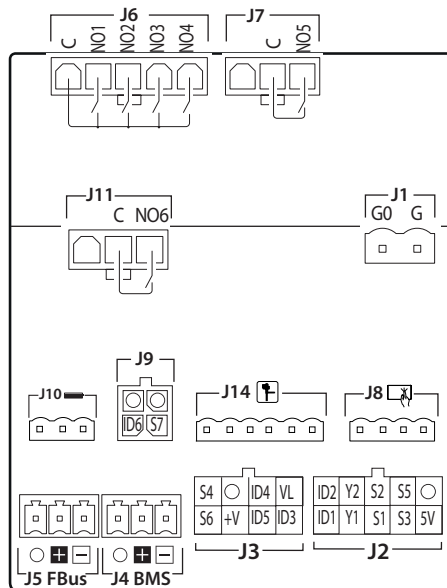

Fig. 2.f

Ref.	Description
J1	G Power supply
	G0 Power supply: reference
J2	5V Ratiometric probe power supply
	S3 Analogue input 3
	S1 Analogue input 1
	Y1 Analogue output 1
	ID1 Digital input 1
	O GND: reference for probes, digital inputs and analogue outputs
	S5 Analogue input 5
	S2 Analogue input 2
	Y2 Analogue output 2
	ID2 Digital input 2
J3	ID3 Digital input 3
	ID5 Digital input 5
	+V Power supply to 4-20 mA active probes
	S6 Analogue input 6
	VL Not used
	ID4 Digital input 4
	O GND: reference for analogue and digital inputs
	S4 Analogue input 4
J4	- BMS serial port (RS485): Rx/Tx-
	+ BMS serial port (RS485): Rx/Tx+
	O BMS serial port (RS485): GND

Ref.	Description
J5	- Fieldbus serial port (RS485): Rx/Tx -
	+ Fieldbus serial port (RS485): Rx/Tx +
	O Fieldbus serial port (RS485): GND
J6	C Common for relays 1, 2, 3, 4
	NO1 Digital output (relay) 1
	NO2 Digital output (relay) 2
	NO3 Digital output (relay) 3
	NO4 Digital output (relay) 4
J7	C Common for relay 5
	NO5 Digital output (relay) 5
J8	- Unit terminal connector (AX5* or PGR04*)
J9	S7 Analogue input 7
	ID6 Digital input 6
	O Input reference
	O Input reference
J10*	G Ultracap module power supply (future use)
	G0
	Vbat Emergency power supply from Ultracap module (future use)
J11	- (not used)
	C Common for relay 6
	NO6 Digital output (relay) 6
J14*	Carel ExV unipolar valve connector

Tab. 2.a

(*) for DIN Enhanced / High Efficiency models only

2.5 Probe/digital input connection

NTC probes

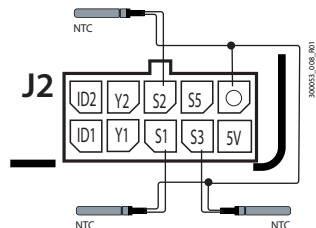

Fig. 2.g

0-5 V ratiometric pressure probes

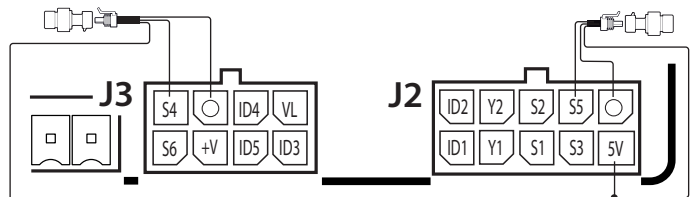

Fig. 2.h

0-10 Vdc probes

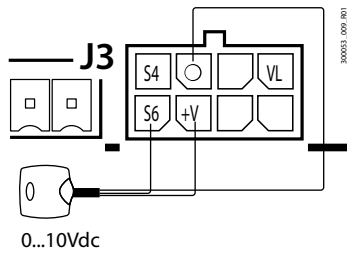

Fig. 2.i

4-20 mA probes/digital inputs

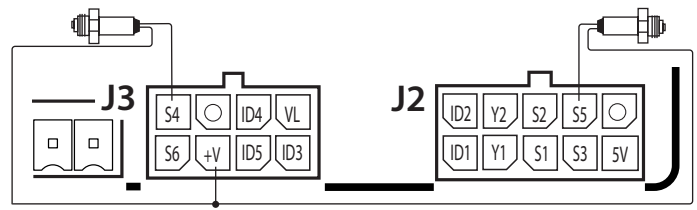

Fig. 2.j

Controller terminals	Pressure probe with current signal	
	1	
+V	Power supply	brown
S1	Signal	white

Tab. 2.b

Controller terminals	Pressure probe with current signal	
	1	
5V	Power supply	black
O	Power reference	green
S1	Signal	white

Tab. 2.c

⚠ Notice: O = GND

⚠ Notice: if an ExV valve is connected, an NTC temperature sensor must also be connected to read the gas suction temperature: this sensor must be connected to one of the available inputs provided. For the position of the sensor on the suction pipe, see the installation guide +040010025 "Sonde e sensori - Guida alla scelta e all'installazione ottimale / Probes and sensors - Selection and optimal installation guide", available at carel.com under product => sensor => quick guide.

2.6 Connection to user terminals

2.6.1 Panel model

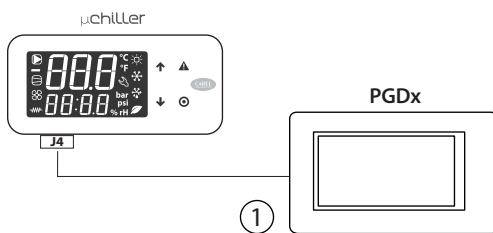

Fig. 2.k

2.6.2 DIN rail model

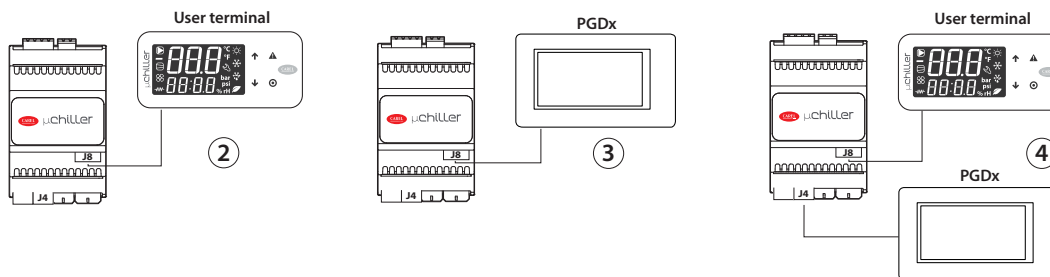

Fig. 2.l

Connection to connector J4

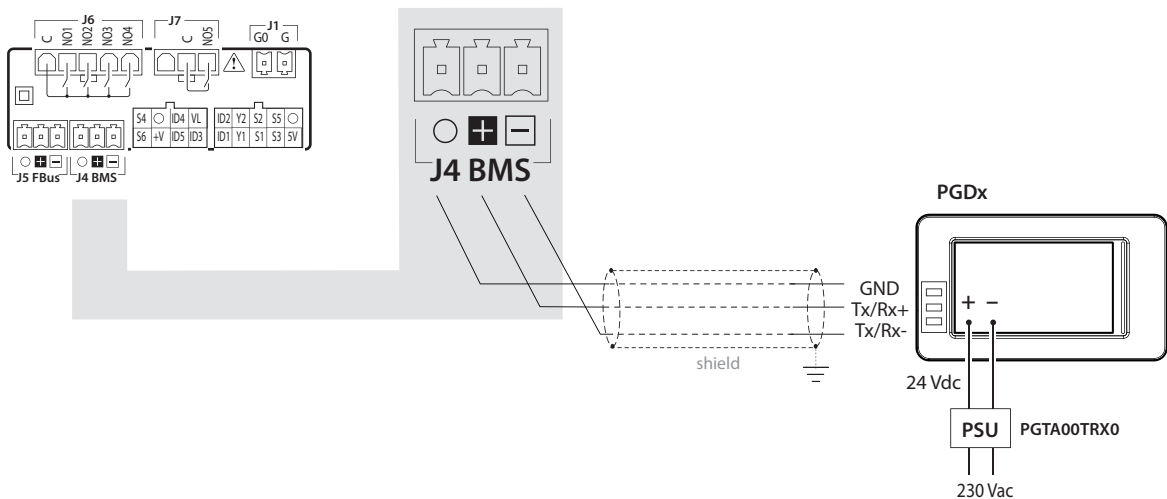

Fig. 2.m

Connection to connector J8

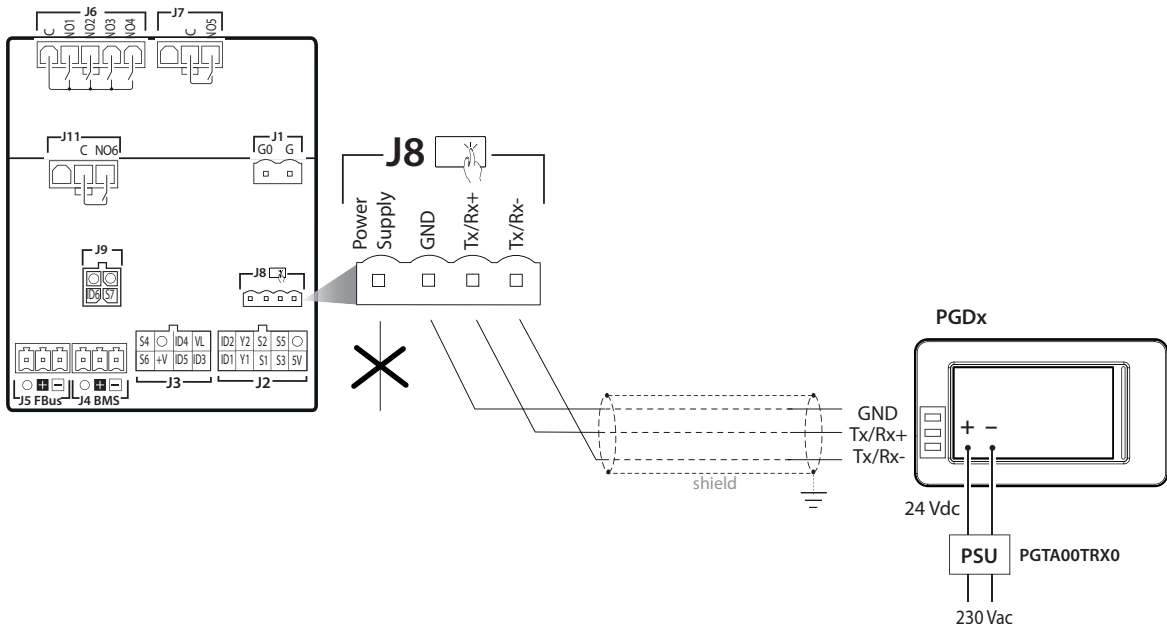

Fig. 2.n

ⓘ **Notice:** (1) and (4) with PGDx connected to port J4 (BMS): the parameters must be set as shown in the following table.

Communication parameters

User	Display	Code	Description	Value
S	x	Hd00	BMS: serial address	1
S	x	Hd01	BMS: baud rate 3=9600; 4=19200; 5=38400; 6=57600; 7=115200	6
S	x	Hd02	BMS: settings 0=8-NONE-1; 1=8-NONE-2; 2=8-EVEN-1; 3=8-EVEN-2; 4=8-ODD-1; 5=8-ODD-2	0

Tab. 2.d

2.7 Positioning inside the panel

The position of the controller in the electrical cabinet must be chosen so as to guarantee correct physical separation from the power components (solenoids, contactors, actuators, inverters, ...) and the connected cables. Proximity to such devices/cables may create random malfunctions that are not immediately evident. The structure of the panel must allow the correct flow of cooling air.

2.8 Electrical installation

▲ Important: When laying the wiring, “physically” separate the power part from the control part. The proximity of these two sets of wires will, in most cases, cause problems of induced disturbance or, over time, malfunctions or damage to the components. The ideal solution is to house these two circuits in two separate cabinets. Sometimes this is not possible, and therefore the power part and the control part must be installed in two separate areas inside the same panel.

For the control signals, it is recommended to use shielded cables with twisted wires. If the control cables have to cross over the power cables, the intersections must be as near as possible to 90 degrees, always avoiding running the control cables parallel to the power cables.

Pay attention to the following warnings:

- use cable ends suitable for the corresponding terminals. Loosen each screw and insert the cable ends, then tighten the screws. When the operation is completed, slightly tug the cables to check they are sufficiently tight;
- separate as much as possible the probe signal, digital input and serial line cables from the cables carrying inductive loads and power cables to avoid possible electromagnetic disturbance. Never run power cables (including the electrical cables) and probe signal cables in the same conduits. Do not install the probe cables in the immediate vicinity of power devices (contactors, circuit breakers or similar);
- reduce the path of the probe cables as much as possible, and avoid spiral paths that enclose power devices;
- avoid touching or nearly touching the electronic components fitted on the boards to avoid electrostatic discharges (extremely damaging) from the operator to the components;
- do not secure the cables to the terminals by pressing the screwdriver with excessive force, to avoid damaging the controller: maximum tightening torque 0.22-0.25 N•m;
- for applications subject to considerable vibrations (1.5 mm pk- pk 10/55 Hz), secure the cables connected to the controller around 3 cm from the connectors using clamps;
- all the extra low voltage connections (analogue and digital inputs, analogue outputs, serial bus connections, power supplies) must have reinforced or double insulation from the mains network.

2.9 Connecting serial ports with two circuits

For serial connections (FBus and BMS ports), the cables used must be suitable for the RS485 standard (shielded twisted pair, see the specifications in the following table). The earth connection of the shield must be made using the shortest connection possible on the metal plate at the bottom of the electrical panel.

Master device	Serial port	Lmax (m)	Wire/wire capacitance (pF/m)	Resistance on first and last device	Max no. of slave devices on bus	Data rate (bit/s)
µChiller	FBus	10	<90	120 Ω	16	19200
PC (supervision)	BMS	500	<90	120 Ω	16	115200

🔊 Notice: 120 Ω 1/4W terminating resistors on the first and last devices in the network must be used when the length exceeds 100 m.

For two-circuit units, the power supply connections must be in phase between the two controllers (G0 on the master controller and G0 on the slave controller connected to the same power supply wire); the serial connection between the two controllers (J5 FBus on the master and J4 BMS on the slave) must be made as shown in the figure (+ with + and - with -).

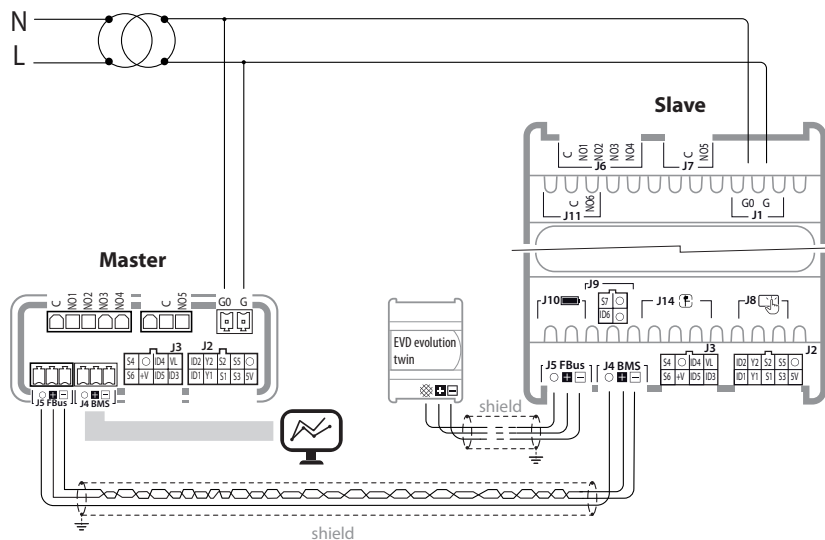

Fig. 2.0

2.10 Connection to Power+ (for BLDC)

For the serial connection between the controller and the Power+ speed drive, see the specific manual. Also see the following diagrams.

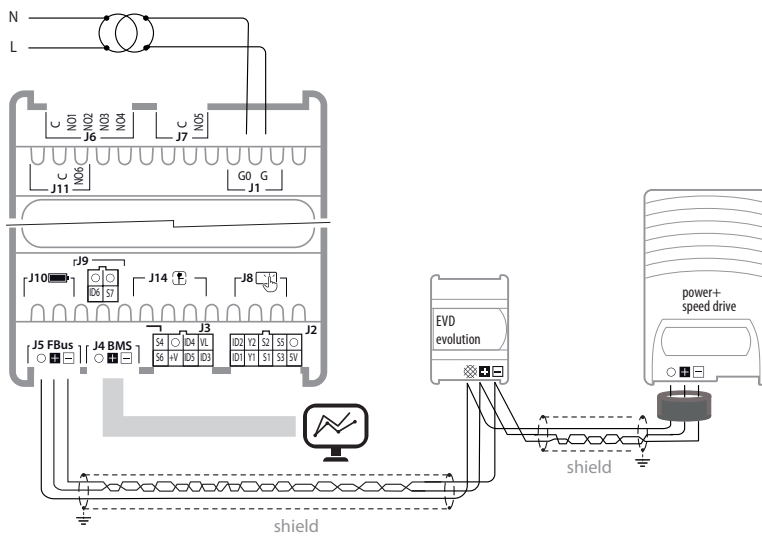

Fig. 2.p

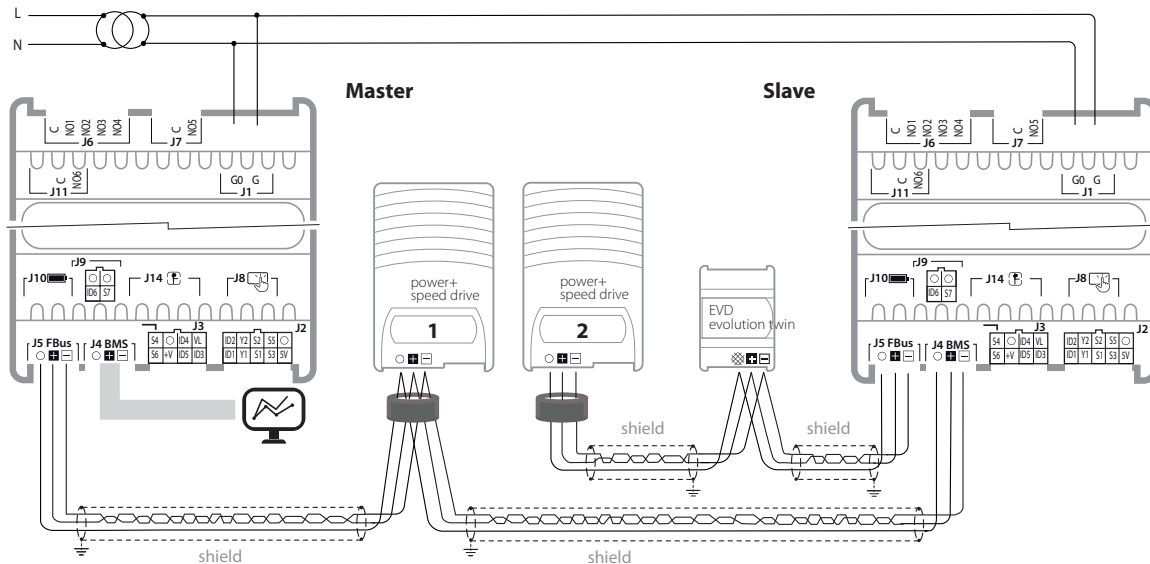

Fig. 2.q

⚠ Notice: if connecting Power+ (for BLDC) and EVD evolution, the connection parameters are not configurable, and must be set as shown in the table.

Device	Address	Network settings	Baudrate
Power+ speed drive 1	1	8 - NONE - 2	19200
Power+ speed drive 2	1	8 - NONE - 2	19200
EVD evolution	198	8 - NONE - 2	19200

Tab. 2.e

2.11 Positioning of probes/ components

Water-cooled unit

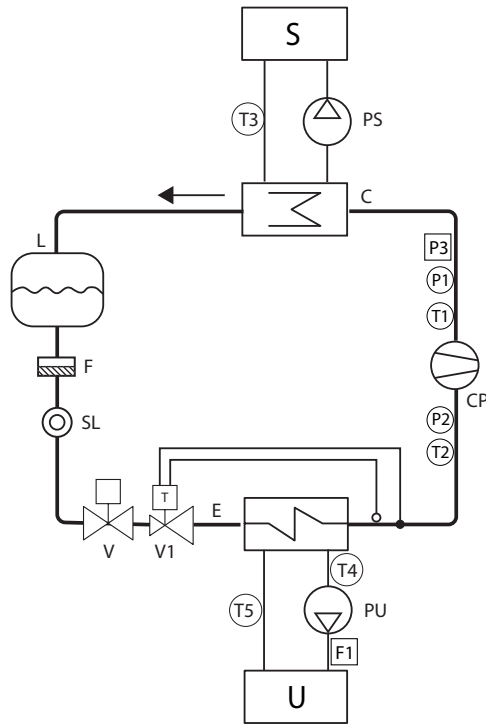

Fig. 2.r

Ref.	Description
S	Source
U	User
E	Evaporator
F	Filter-drier
L	Liquid receiver
CP	Compressor
C	Condenser
SL	Liquid sightglass
P1	Condensing pressure probe
V	Solenoid valve
V1	Thermostatic expansion valve

Air-cooled unit

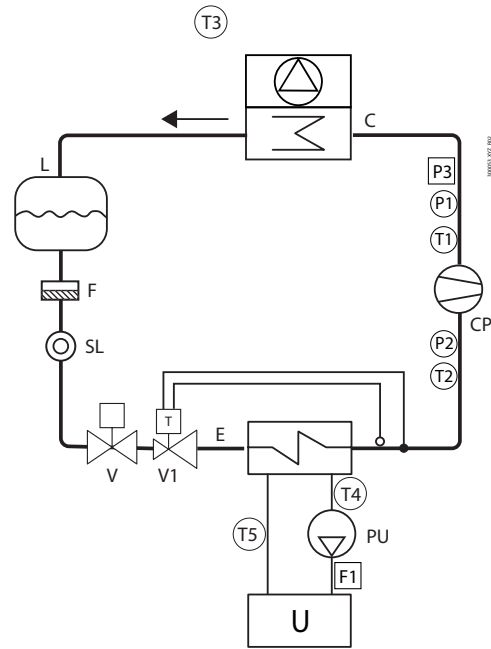

Fig. 2.s

Ref.	Description
PU	User pump
PS	Source pump
P2	Evaporation pressure probe
T1	Discharge temperature
T2	Suction temperature
P3	High pressure switch
T3	Outside air temperature
F1	User pump flow switch
T4	Water delivery temperature (to) user
T5	Water return temperature (from) user
T6	Water delivery temperature (to) source

Tab. 2.f

2.12 Input/output configuration

Information on how to configure the µChiller Legacy inputs and outputs to replace mCH2 and mCH2 SE is shown below.

Panel mounting model

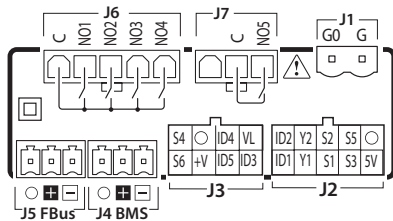

Fig. 2.t

DIN rail model (Basic)

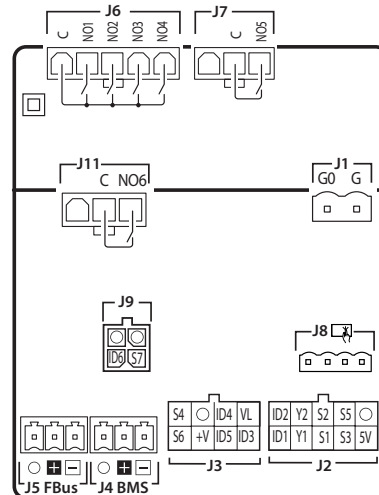

Fig. 2.u

2.12.1 Analogue inputs

The analogue inputs on μ Chiller Legacy are divided into four groups, according to the type of sensor connected. The groups and the list of parameters used to configure the different analogue inputs are shown below:

Group	Sensor	Master config. parameter	Slave config. parameter
GRP1	S1	HC31	HC41
	S2	HC32	HC42
	S3	HC00	HC43
GRP2	S4	HC34	HC44
	S5	HC35	HC45
GRP3	S6	HC03	HC05
GRP1*	S7*	HC04*	HC47

Tab. 2.g

(*) available only on DIN version

The meanings assigned to the analogue inputs according to the various groups for the Master controller (circuit 1) are as follows:

Value	GRP1	GRP2	GRP3
0	Source water delivery temp.	Source water delivery temp.	Source water delivery temp.
1	Outside temperature	Outside temperature	Outside temperature
2	Discharge temperature circuit 1	Discharge temperature circuit 1	Remote set point
3	Condensing temperature circ. 1	Condensing temperature circ. 1	Discharge temperature circuit 1
4	Suction temperature circ. 1	Suction temperature circ. 1	Condensing temperature circ. 1
5	Evaporation temperature circ. 1	Evaporation temperature circ. 1	Suction temperature circ. 1
6	System water return temperature	Condensing pressure circ. 1	Evaporation temperature circ. 1
7	System water delivery temp.	Evaporation pressure circ. 1	Condensing pressure circ. 1
8		System water return temperature	Evaporation pressure circ. 1
9		System water delivery temp.	System water return temperature
10			System water delivery temp.
11			System water delivery temp.

Tab. 2.h

The meanings assigned to the analogue inputs according to the various groups for the Slave controller (circuit 2) are as follows:

Value	GRP1	GRP2	GRP3
0	Not used	Not used	Not used
1	Source water delivery temp.	Source water delivery temp.	Source water delivery temp.
2	Outside temperature	Outside temperature	Outside temperature
3	Discharge temperature circuit 2	Discharge temperature circuit 2	Remote set point
4	Condensing temperature circ. 2	Condensing temperature circ. 2	Discharge temperature circuit 2
5	Suction temperature circ. 2	Suction temperature circ. 2	Condensing temperature circ. 2
6	Evaporation temperature circ. 2	Evaporation temperature circ. 2	Suction temperature circ. 2
7	Common delivery water temperature	Condensing pressure circ. 2	Evaporation temperature circ. 2
8	Evap. water delivery temp. 2	Evaporation pressure circ. 2	Condensing pressure circ. 2
9		Common water delivery temperature	Evaporation pressure circ. 2
10		Evap. water delivery temp. 2	Common water delivery temperature
11			Evaporator 2 water outlet temperature

Tab. 2.i

2.12.2 Digital inputs

Below is the list of parameters used to configure the digital inputs:

Digital input	Master configuration parameter	Slave configuration parameter
ID1	HC14	HC16
ID2	HC15	HC17
ID3	High pressure switch circ. 1	High pressure switch circ. 2
ID4	HC06	HC09
ID5	HC07	HC10
ID6*	HC08*	HC11

Tab. 2.j

(*) available only on DIN version

The digital input configuration parameters can have the following meaning:

Value	Master description (circuit 1)	Slave description (circuit 2)
0	Not used	Not used
1	User pump flow switch	User pump flow switch
2*	Comp. 1 thermal protector circ. 1	Comp. 1 thermal prot circ. 2
3*	Comp. 2 thermal protector circ. 1	Comp. 2 thermal prot. circ. 2
4	Remote on/off	Remote on/off
5	Cooling/heating	Cooling/heating
6	2nd set point	2nd set point
7	Remote alarm	Remote alarm
8	User pump 1 thermal protector	User pump 1 thermal protector
9	Low pressure switch circ. 1	Low pressure switch circ. 2
10	User pump 2 thermal protector	User pump 2 thermal protector
11**	Comp. 1 request circ. 1	Comp. 1 request circ. 2
12**	Comp. 2 request circ. 1	Comp. 2 request circ. 2

Tab. 2.k

(*) In the Legacy model, compressor 1 thermal protector circ.1 and compressor 1 thermal protector circ. 2 are circuit 1 and circuit 2 thermal protector respectively. In the Legacy model, compressor 2 thermal protector circ.1 and compressor 2 thermal protector circ. 2 are not used.

(**) available only for condensing units

2.12.3 Analogue outputs

Below is the list of parameters used to configure the analogue outputs:

Analogue output	Master configuration parameter	Slave configuration parameter
Y1	HC71	HC81
Y2	HC72	HC82

Tab. 2.l

The analogue input configuration parameters can have the following meaning:

Value	Master description (circuit 1)	Slave description (circuit 2)
0	Not used	Not used
1	On-off source fan/pump circ. 1	On-off source fan/pump circ. 2
2	Modulating source fan circ. 1	Modulating source fan circ. 2
3	Free cooling	Free cooling

Tab. 2.m

2.12.4 Digital outputs

Below is the list of parameters used to configure the digital outputs:

Digital input	Master configuration parameter	Slave configuration parameter
NO1	HC51	HC61
NO2	HC52	HC62
NO3	HC53	HC63
NO4	HC54	HC64
NO5	HC55	HC65
NO6*	HC56	HC66

Tab. 2.n

(*) available only on DIN version

The digital output configuration parameters can have the following meaning:

Value	Master description (circuit 1)	Slave description (circuit 2)
0	Not used	Not used
1	Compressor1 circuit 1	Compressor1 circuit 2
2	Compressor 2 circuit 1	Compressor 2 circuit 2
3	User heater 1	User heater 2
4	User pump 1 / user fan	User pump 2
5	Source pump / fan	Source pump / fan
6	Frost protection heater evaporator 1	Frost protection heater evaporator 2
7	4-way valve circuit 1	4-way valve circuit 2
8	Oil equalisation valve circuit 1	Oil equalisation valve circuit 2
9	Freecooling valve	
10	General alarm	
11	User pump 2	
12	User heater 2	

Tab. 2.o

2.13 Functional diagrams

2.13.1 Chillers, On/Off compressors and thermostatic expansion valve

▲ Important: The black lines refer to the electrical connections, the grey lines the serial connections between controller and options (I/O expansion for the second circuit, EVD EVO and Power+).

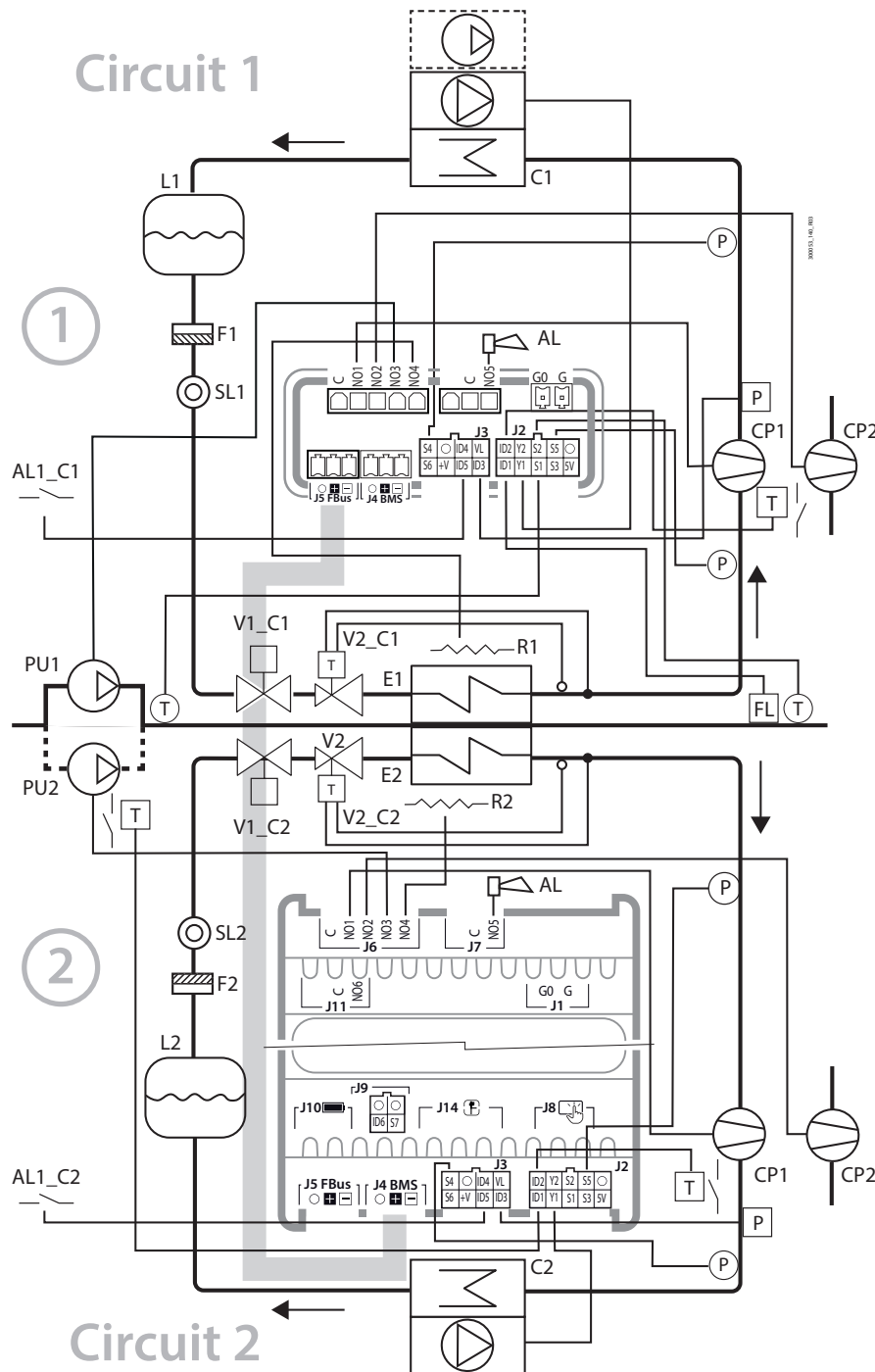

Fig. 2.v

Ref.	Description
C1/C2	Condenser 1/2
E1/E2	Evaporator 1/2
V1_C1	Solenoid valve circuit 1
V1_C2	Solenoid valve circuit 2
V2_C1	Thermostatic expansion valve circuit 1
V2_C2	Thermostatic expansion valve circuit 2

Ref.	Description
PU1/2	User pump 1/2
L1/2	Liquid receiver 1/2
SL1/2	Liquid sightglass 1/2
F1/2	Filter-drier 1/2
FL	Flow switch
AL	Alarm

Ref.	Description
AL1_C1/2	Remote alarm circuit 1/2
CP1/2	Compressor 1/2
R1/2	Frost protection heater 1/2
P	Pressure probe/pressure switch
T	Temperature probe/thermostat

Tab. 2.p

Analogue inputs - Master circuit 1

Ref.	Description	Type	Configuration parameters
S1	Return temperature from user	NTC	Hc31
S2	Delivery temperature to user	NTC	Hc32
S3	Not present	-	Hc00
S4	Condensing pressure	0-5V	Hc34; C040; C041; C042
S5	Evaporation pressure	0-5V	Hc35; C037; C038; C039
S6	Not present	-	Hc03; U025; U026; U027

Tab. 2.q

Analogue inputs - Slave circuit 2

Ref.	Description	Type	Configuration parameters
S1	Not present	-	Hc41
S2	Not present	-	Hc42
S3	Not present	-	Hc43
S4	Condensing pressure	0-5V	Hc44; C040; C041; C042
S5	Evaporation pressure	0-5V	Hc45; C037; C038; C039
S6	Not present	-	Hc05; U025; U026; U027

Tab. 2.r

☛ **Notice:** the discharge temperature probe is automatically assigned type NTC-HT.

Digital inputs - Master circuit 1

Ref.	Description	Configuration parameters
ID1	User pump flow switch	Hc14; U060
ID2	Compressor 1 overload	Hc15; C035
ID3	High pressure switch	C034
ID4	Not present	Hc06; C035; U059; U058; U062; U057; U061
ID5	Remote alarm	Hc07; C035; U059; U058; U062; U057; U061

Tab. 2.s

Digital inputs - Slave circuit 2

Ref.	Description	Configuration parameters
ID1	Pump 2 overload	Hc16; U061
ID2	Compressor 1 overload	Hc17; C035
ID3	High pressure switch	C034
ID4	Not present	Hc09; C035; U059; U058; U062; U057; U061
ID5	Not present	Hc10;
ID6	Not present	Hc11

Tab. 2.t

Digital outputs - Master circuit 1

Ref.	Description	Configuration parameters
C-NO1	Compressor 1	Hc51; C036
C-NO2	Compressor 2	Hc52; C036
C-NO3	User pump 1	Hc53; U063
C-NO4	Frost protection heater (*)	Hc54; U066; S063; U065
C5-NO5	Alarm	Hc55; U064

Tab. 2.u

Digital outputs - Slave circuit 2

Ref.	Description	Configuration parameters
C-NO1	Compressor 1	Hc61; C036
C-NO2	Compressor 2	Hc62; C036
C-NO3	User pump 2	Hc63; U063
C-NO4	Frost protection heater (*)	Hc64; U066; S063; U065
C5-NO5	Not used	Hc65; U064
C6-NO6	Not used	Hc66

Tab. 2.v

☛ **Notice:** (*) the configuration of the output depends on the type of unit: heat pump (reverse-cycle) => reversing valve; Chiller with free cooling (master only) => FC valve; otherwise => Frost protection heater.

Analogue outputs - Master circuit 1

Ref.	Description	Type	Configuration parameters	Notes
Y1	Modulating/On-Off fan	0-10V	Hc71	FCS1*0 /CONVONOFF
Y2	Not used	0-10V	Hc72	

Tab. 2.w

Analogue outputs - Slave circuit 2

Ref.	Description	Type	Configuration parameters	Notes
Y1	Modulating/On-Off fan	0-10V	Hc81	FCS1*0 /CONVONOFF
Y2	Not used	0-10V	Hc82	

Tab. 2.x

2.13.2 Chillers, On/Off compressors with free cooling and thermostatic expansion valve

▲ Important: The black lines refer to the electrical connections, the grey lines the serial connections between controller and options (I/O expansion for the second circuit, EVD EVO and Power+).

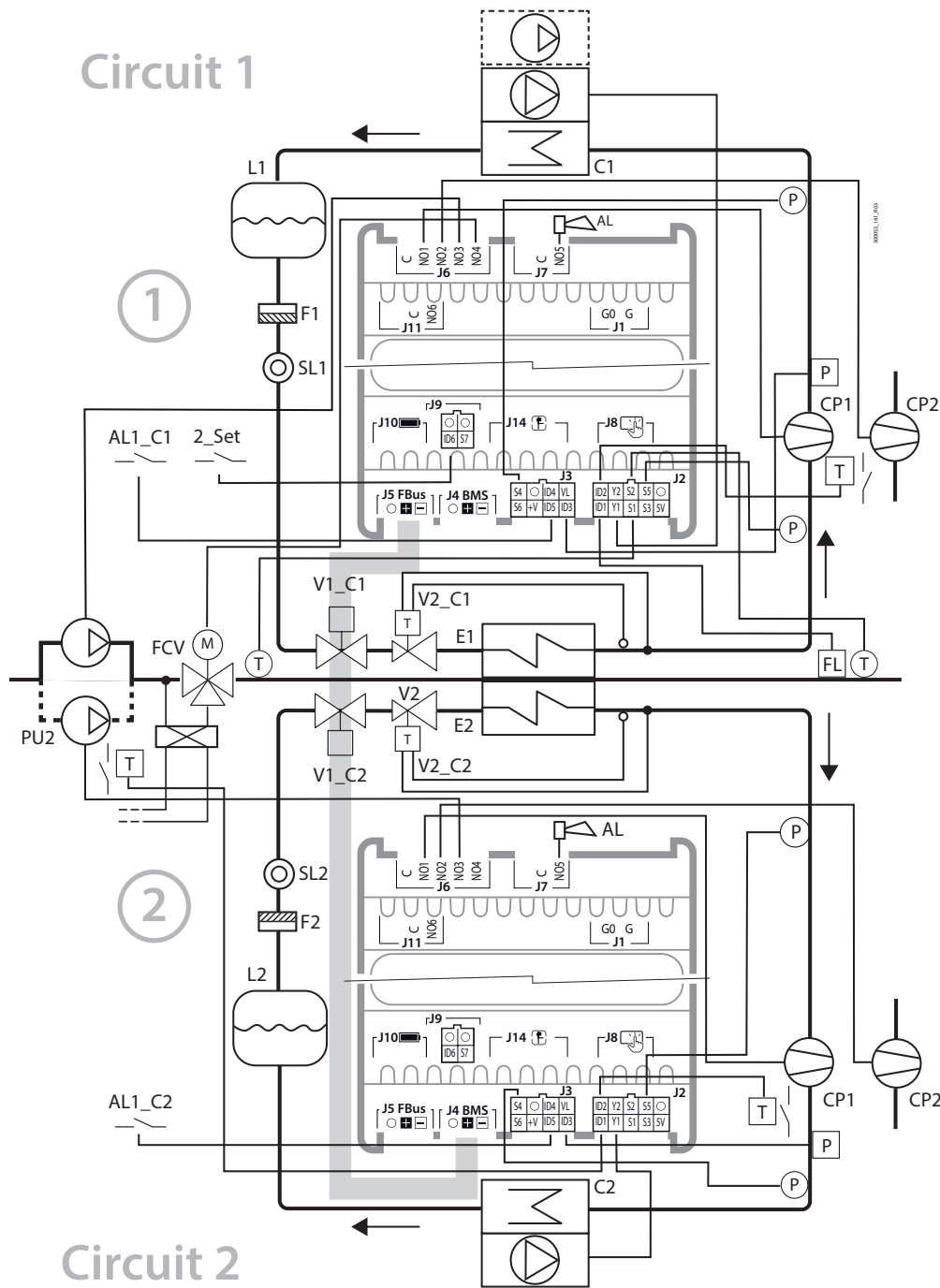

Fig. 2.w

Ref.	Description	Ref.	Description	Ref.	Description
C1/C2	Condenser 1/2	FCV	Free cooling valve	P	Pressure probe/pressure switch
E1/E2	Evaporator 1/2	SL1/2	Liquid sightglass 1/2	T	Temperature probe/thermostat
V1_C1	Solenoid valve circuit 1	F1/2	Filter-drier 1/2	AL	Alarm
V1_C2	Solenoid valve circuit 2	FL	Flow switch	AL1_C1/2	Remote alarm circuit 1/2
V2_C1	Thermostatic expansion valve circuit 1	CP1/2	Compressor 1/2	2_Set	2nd set point
V2_C2	Thermostatic expansion valve circuit 2	PU1/2	User pump 1/2	L1/2	Liquid receiver 1/2

Tab. 2.y

Analogue inputs - Master circuit 1

Ref.	Description	Type	Configuration parameters
S1	Return temperature from user	NTC	Hc31
S2	Delivery temperature to user	NTC	Hc32
S3	Not present	-	Hc00
S4	Condensing pressure	0-5V	Hc34; C040; C041; C042
S5	Evaporation pressure	0-5V	Hc35; C037; C038; C039
S6	Not present	-	Hc03; U025; U026; U027

Tab. 2.z

Analogue inputs - Slave circuit 1

Ref.	Description	Type	Configuration parameters
S1	Not present	-	Hc41
S2	Not present	-	Hc42
S3	Not present	-	Hc43
S4	Condensing pressure	0-5V	Hc44; C040; C041; C042
S5	Evaporation pressure	0-5V	Hc45; C037; C038; C039
S6	Not present	-	Hc05; U025; U026; U027

Tab. 2.aa

Notice: the discharge temperature probe is automatically assigned type NTC-HT.

Digital inputs - Master circuit 1

Ref.	Description	Configuration parameters
ID1	User pump flow switch	Hc14; U060
ID2	Compressor 1 overload	Hc15; C035
ID3	High pressure switch	C034
ID4	Not present	Hc06; C035; U059; U058; U062; U057; U061
ID5	Not present	Hc07; C035; U059; U058; U062; U057; U061
ID6	Not present	Hc08; C035; U059; U058; U062; U057; U061

Tab. 2.ab

Ingressi digitali - Slave circuito 2

Ref.	Description	Configuration parameters
ID1	Pump 2 overload	Hc16; U061
ID2	Compressor 1 overload	Hc17; C035
ID3	High pressure switch	C034
ID4	Not present	Hc09; C035; U059; U058; U062; U057; U061
ID5	Remote alarm	Hc10
ID6	Not present	Hc11

Tab. 2.ac

Digital outputs - Master circuit 1

Ref.	Description	Configuration param.s
C-NO1	Compressor 1	Hc51; C036
C-NO2	Compressor 2	Hc52; C036
C-NO3	User pump 1	Hc53; U063
C-NO4	Free cooling valve (*)	Hc54; U066; S063; U065
C5-NO5	Alarm	Hc55; U064
C6-NO6	Not used	Hc56

Tab. 2.ad

Digital outputs - Slave circuit 2

Ref.	Description	Configuration param.s
C-NO1	Compressor 1	Hc61; C036
C-NO2	Compressor 2	Hc62; C036
C-NO3	User pump 2	Hc63; U063
C-NO4	Not used	Hc64
C5-NO5	Alarm	Hc65
C6-NO6	Not used	Hc66

Tab. 2.ae

Notice: (*) the configuration of the output depends on the type of unit: heat pump (reverse-cycle) => reversing valve; Chiller with free cooling => FC valve; otherwise => Frost protection heater.

Analogue outputs - Master circuit 1

Ref.	Description	Type	Configuration parameters	Notes
Y1	Modulating/On-Off fan	0-10V	Hc71	FCS1*0/CONVONOFF
Y2	Not used	0-10V	Hc72	

Tab. 2.af

Analogue outputs - Slave circuit 2

Ref.	Description	Type	Configuration parameters	Notes
Y1	Modulating/On-Off fan	0-10V	Hc81	FCS1*0/CONVONOFF
Y2	Not used	0-10V	Hc82	

Tab. 2.ag

2.13.3 Chillers/heat pumps, On/Off compressors and bipolar ExV expansion valve

▲ Important: The black lines refer to the electrical connections, the grey lines the serial connections between controller and options (I/O expansion for the second circuit, EVD EVO and Power+).

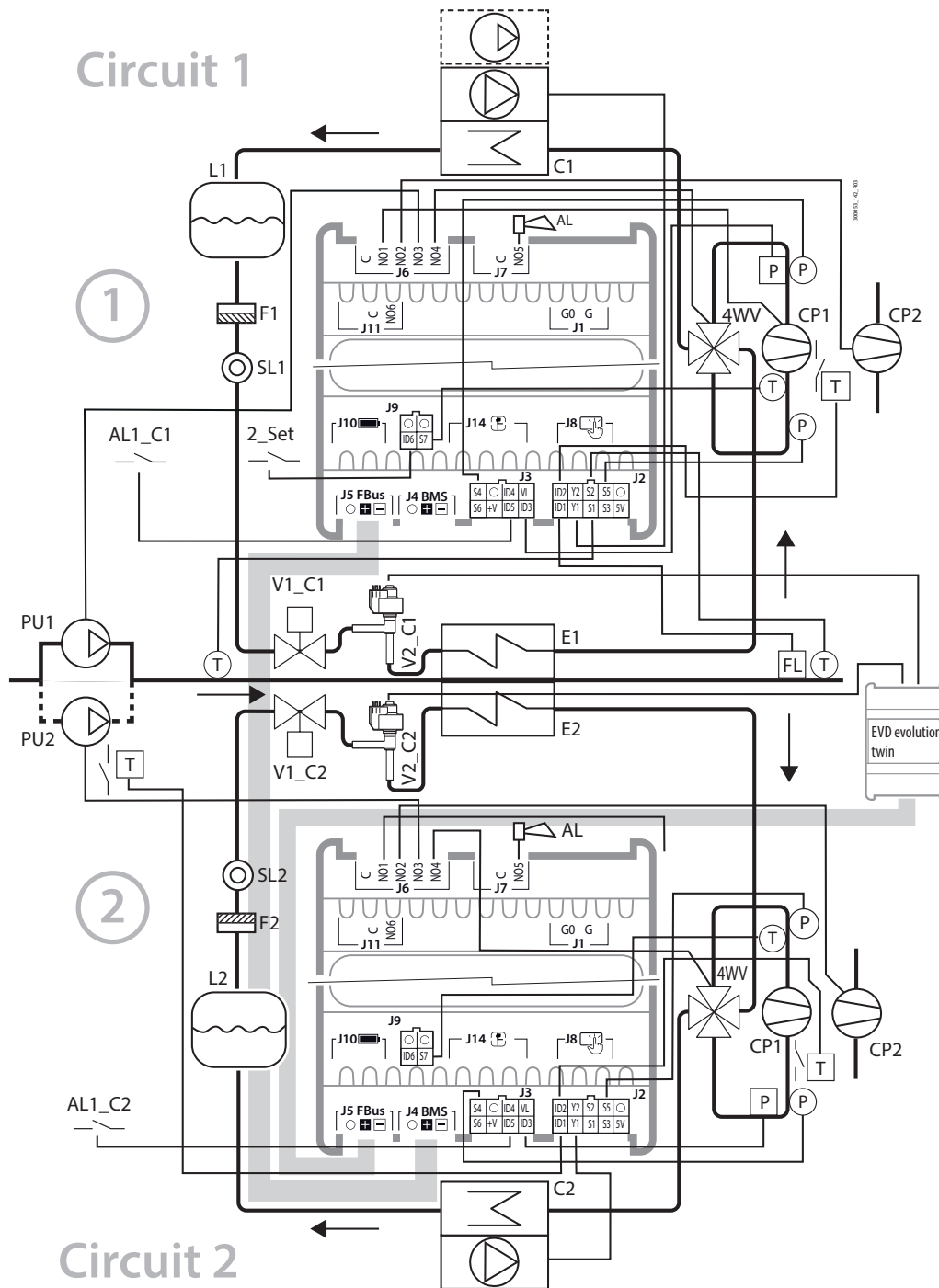

Fig. 2.x

Ref.	Description	Ref.	Description	Ref.	Description
C1/C2	Condenser 1/2	SL1/2	Liquid sightglass 1/2	4WV	Reversing valve
E1/E2	Evaporator 1/2	F1/2	Filter-drier 1/2	P	Pressure probe/pressure switch
V1_C1	Solenoid valve circuit 1	FL	Flow switch	T	Temperature probe/thermostat
V1_C2	Solenoid valve circuit 2	CP1/2	Compressor 1/2	PU1/2	User pump 1/2
V2_C1	Electronic expansion valve circuit 1	L1/2	Liquid receiver 1/2	AL	Alarm
V2_C2	Electronic expansion valve circuit 2	AL1_C1/2	Remote alarm circuit 1/2	2_Set	2nd set point

Tab. 2.ah

Analogue inputs - Master circuit 1

Ref.	Description	Type	Configuration parameters
S1	Return temperature from user	NTC	Hc31
S2	Delivery temperature to user	NTC	Hc32
S3	Not present	-	Hc00
S4	Condensing pressure	0-5V	Hc34; C040; 041; C042
S5	Evaporation pressure	0-5V	Hc35; C037; C038; C039
S6	Not present	-	Hc03; U025; U026; U027
S7	Suction temperature	NTC	Hc04

Tab. 2.ai

Analogue inputs - Slave circuit 2

Ref.	Description	Type	Configuration parameters
S1	Not present	-	Hc41
S2	Not present	-	-Hc42
S3	Not present	-	Hc43
S4	Condensing pressure	0-5V	Hc44; C040; C041; C042
S5	Evaporation pressure	0-5V	Hc45; C037; C038; C039
S6	Not present	-	Hc05; U025; U026; U027
S7	Suction temperature	NTC	Hc47

Tab. 2.aj

☛ **Notice:** the discharge temperature probe is automatically assigned type NTC-HT.

Digital inputs - Master circuit 1

Ref.	Description	Configuration parameters
ID1	User pump flow switch	Hc14; U060
ID2	Compressor 1 overload	Hc15; C035
ID3	High pressure switch	C034
ID4	Not present	Hc06; C035; U059; U058; U062; U057; U061
ID5	Remote alarm	Hc07; C035; U059; U058; U062; U057; U061
ID6	2nd set point	Hc08; C035; U059; U058; U062; U057; U061

Tab. 2.ak

Digital inputs - Slave circuit 2

Ref.	Description	Configuration parameters
ID1	Pump 2 overload	Hc16; U061
ID2	Compressor 1 overload	Hc17; C035
ID3	High pressure switch	C034
ID4	Not used	Hc09; C035; U059; U058; U062; U057; U061
ID5	Not used	Hc10; C035; U059; U058; U062; U057; U061
ID6	Not used	Hc11

Tab. 2.al

Digital outputs - Master circuit 1

Ref.	Description	Configuration param.
C-NO1	Compressor 1	Hc51; C036
C-NO2	Compressor 2	Hc52; C036
C-NO3	User pump 1	Hc53; U063
C-NO4	Reversing valve	Hc54; U066; S063; U065
C5-NO5	Alarm	Hc55; U064
C6-NO6	Not used	Hc56

Tab. 2.am

Digital outputs - Slave circuit 2

Ref.	Description	Configuration param.
C-NO1	Compressor 1	Hc61; C036
C-NO2	Compressor 2	Hc62; C036
C-NO3	User pump 2	Hc63; U063
C-NO4	Reversing valve	Hc64; U066; S063; U065
C5-NO5	Alarm	Hc65
C6-NO6	Not used	Hc66

Tab. 2.an

☛ **Notice:** (*) the configuration of the output depends on the type of unit: heat pump (reverse-cycle) => reversing valve; Chiller with free cooling => FC valve; otherwise => Frost protection heater.

Analogue outputs - Master circuit 1

Ref.	Description	Type	Configuration parameters	Notes
Y1	Modulating/On-Off fan	0-10V	Hc71	FCS1*0/CONVONOFF
Y2	Not used	0-10V	Hc72	

Tab. 2.a0

Analogue outputs - Slave circuit 2

Ref.	Description	Type	Configuration parameters	Notes
Y1	Modulating/On-Off fan	0-10V	Hc81	FCS1*0/CONVONOFF
Y2	Not used	0-10V	Hc82	

Tab. 2.ap

2.13.4 Chiller/water-to-water heat pump, On/Off compressors and bipolar ExV expansion valve

▲ Important: The black lines refer to the electrical connections, the grey lines the serial connections between controller and options (I/O expansion for the second circuit, EVD EVO and Power+).

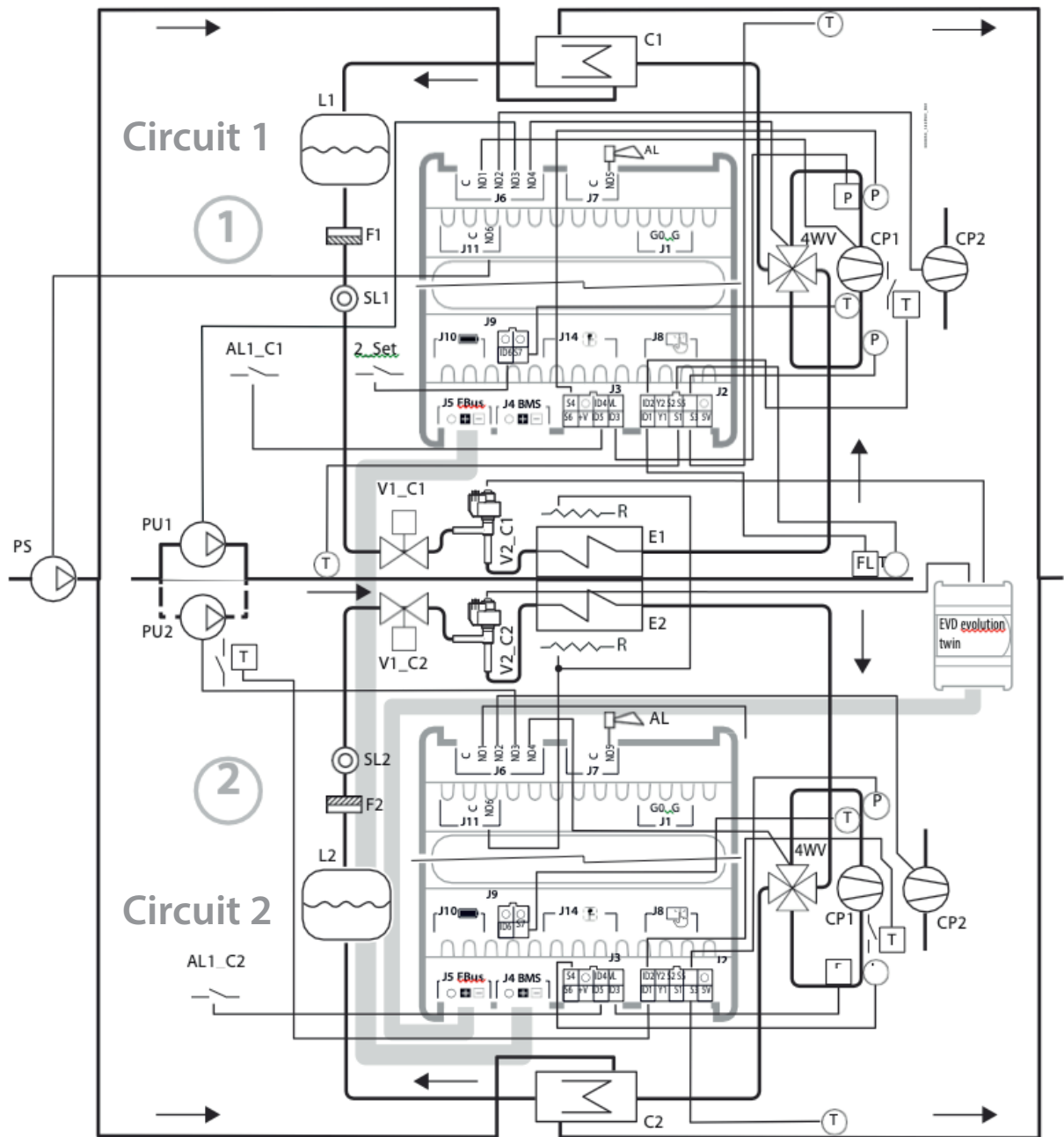

Fig. 2.y

Ref.	Description
C1/C2	Condenser 1/2
E1/E2	Evaporator 1/2
V1_C1	Solenoid valve circuit 1
V1_C2	Solenoid valve circuit 2
V2_C1	Electronic expansion valve circuit 1
V2_C2	Electronic expansion valve circuit 2
R1/2	Frost protection heater

Ref.	Description
SL1/2	Liquid sightglass 1/2
F1/2	Filter-drier 1/2
FL	Flow switch
CP1/2	Compressor 1/2
PU1/2	User pump 1/2
PS	Source pump
2_Set	2nd set point

Ref.	Description
4WV	Reversing valve
P	Pressure probe/pressure switch
AL	Alarm
T	Temperature probe/thermostat
L1/2	Liquid receiver 1/2
AL1_C1/2	Remote alarm circuit 1/2

Tab. 2.aq

Analogue inputs - Master circuit 1

Ref.	Description	Type	Configuration parameters
S1	Return temperature from user	NTC	Hc31
S2	Delivery temperature to user	NTC	Hc32
S3	Source water delivery temperature	NTC	Hc00
S4	Condensing pressure	0-5V	Hc34; C040; C041; C042
S5	Evaporation pressure	0-5V	Hc35; C037; C038; C039
S6	Not present	-	Hc03; U025; U026; U027
S7	Suction temperature	NTC	Hc04

Tab. 2.ar

Analogue inputs - Slave circuit 2

Ref.	Description	Type	Configuration parameters
S1	Not present	-	Hc41
S2	Not present	-	Hc42
S3	Source water delivery temperature	NTC	Hc00
S4	Condensing pressure	0-5V	Hc44; C040; C041; C042
S5	Evaporation pressure	0-5V	Hc45; C037; C038; C039
S6	Not present	-	Hc05; U025; U026; U027
S7	Suction temperature	NTC	Hc47

Tab. 2.as

☛ **Notice:** the discharge temperature probe is automatically assigned type NTC-HT.

Digital inputs - Master circuit 1

Ref.	Description	Configuration parameters
ID1	User pump flow switch	Hc14; U060
ID2	Compressor 1 overload	Hc15; C035
ID3	High pressure switch	C034
ID4	Not present	Hc06; C035; U059; U058; U062; U057; U061
ID5	Remote alarm	Hc07; C035; U059; U058; U062; U057; U061
ID6	2nd set point	Hc08; C035; U059; U058; U062; U057; U061

Tab. 2.at

Digital inputs - Slave circuit 2

Ref.	Description	Configuration parameters
ID1	Pump 2 overload	Hc16; U061
ID2	Compressor 1 overload	Hc17; C035
ID3	High pressure switch	C034
ID4	Not present	Hc09; C035; U059; U058; U062; U057; U061
ID5	Not present	Hc10; C035; U059; U058; U062; U057; U061
ID6	Not present	Hc11

Tab. 2.au

Digital outputs - Master circuit 1

Ref.	Description	Configuration param.s
C-NO1	Compressor 1	Hc51; C036
C-NO2	Compressor 2	Hc52; C036
C-NO3	User pump 1	Hc53; U063
C-NO4	Reversing valve	Hc54; U066; S063; U065
C5-NO5	Alarm	Hc55; U064
C6-NO6	Source water pump	Hc56; Hc12

Tab. 2.av

Digital outputs - Slave circuit 2

Ref.	Description	Configuration param.s
C-NO1	Compressor 1	Hc61; C036
C-NO2	Compressor 2	Hc62; C036
C-NO3	User pump 2	Hc63; U063
C-NO4	Reversing valve	Hc64; U066; S063; U065
C5-NO5	Alarm	Hc65
C6-NO6	Frost protection heater	Hc66

Tab. 2.aw

☛ **Notice:** (*) the configuration of the output depends on the type of unit: heat pump (reverse-cycle) => reversing valve; Chiller with free cooling => FC valve; otherwise => Frost protection heater.

Analogue outputs - Master circuit 1

Ref.	Description	Type	Configuration parameters	Notes
Y1	On-Off source pump (panel model)	0-10V	Hc71	CONVONOFF
Y2	Not used	0-10V	Hc72	

Tab. 2.ax

Analogue outputs - Slave circuit 2

Ref.	Description	Type	Configuration parameters	Notes
Y1	Not used	0-10V	Hc81	--
Y2	Not used	0-10V	Hc82	

Tab. 2.ay

2.13.5 Chillers, On/Off compressors and unipolar ExV expansion valve

▲ Important: The black lines refer to the electrical connections, the grey lines the serial connections between controller and options (I/O expansion for the second circuit, EVD EVO and Power+).

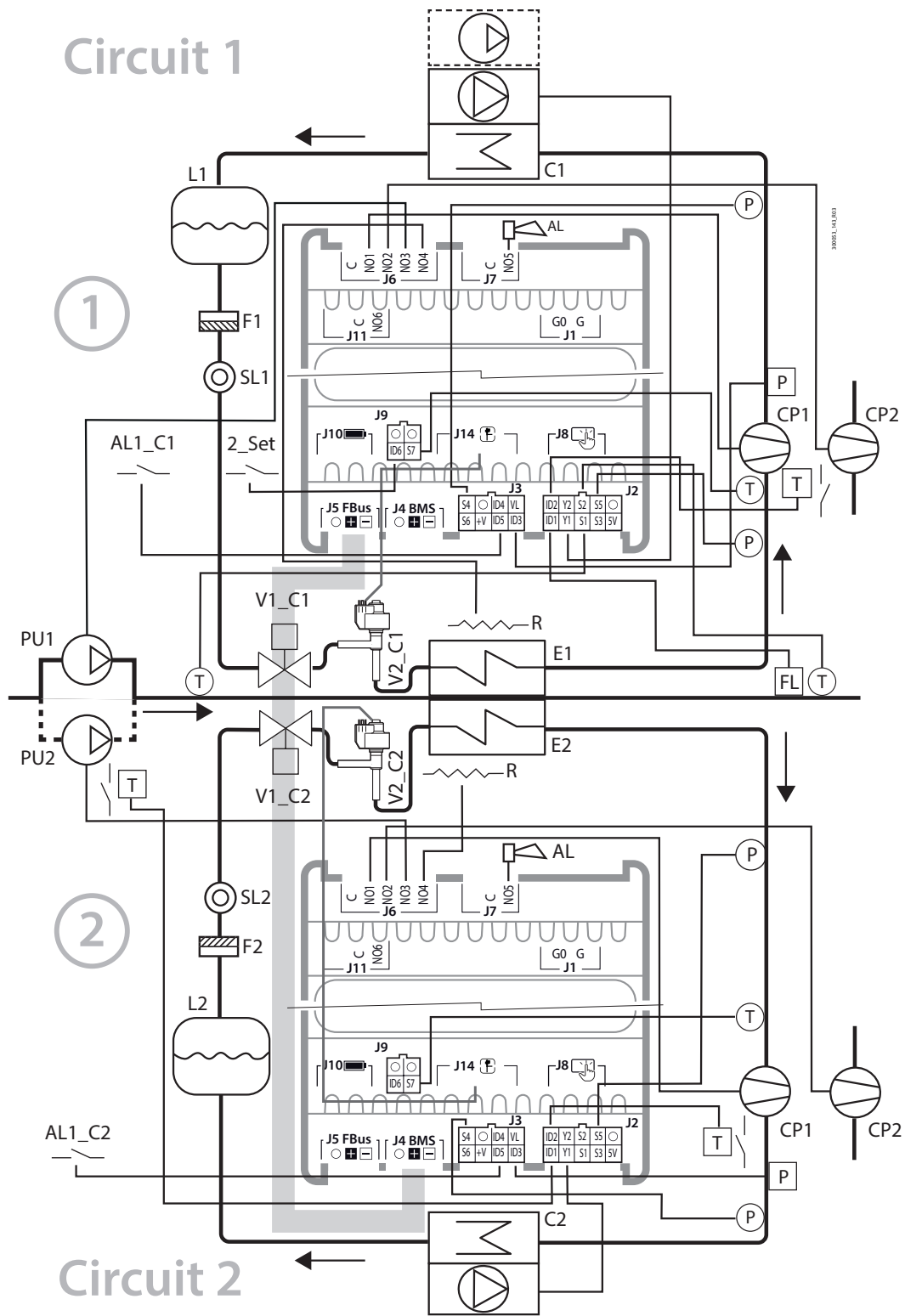

Fig. 2.z

Ref.	Description
C1/C2	Condenser 1/2
E1/E2	Evaporator 1/2
V1_C1	Solenoid valve circuit 1
V1_C2	Solenoid valve circuit 2
V2_C1	Electronic expansion valve circuit 1
V2_C2	Electronic expansion valve circuit 2

Ref.	Description
SL1/2	Liquid sightglass 1/2
F1/2	Filter-drier 1/2
FL	Flow switch
PU1/2	User pump 1/2
L1/2	Liquid receiver 1/2
2_Set	2nd set point

Ref.	Description
R1/2	Frost protection heater
P	Pressure probe/pressure switch
T	Temperature probe/thermostat
CP1/2	Compressor 1/2
AL	Alarm
AL1_C1/2	Remote alarm circuit 1/2

Tab. 2.az

Analogue inputs - Master circuit 1

Ref.	Description	Type	Configuration parameters
S1	Return temperature from user	NTC	Hc31
S2	Delivery temperature to user	NTC	Hc32
S3	Not present	-	Hc00
S4	Condensing pressure	0-5V	Hc34; C040; 041; C042
S5	Evaporation pressure	0-5V	Hc35; C037; C038; C039
S6	Not present	-	Hc03; U025; U026; U027
S7	Suction temperature	NTC	Hc04

Tab. 2.ba

Analogue inputs - Slave circuit 2

Ref.	Description	Type	Configuration parameters
S1	Not present	-	Hc41
S2	Not present	-	Hc42
S3	Not present	-	Hc00
S4	Condensing pressure	0-5V	Hc44; C040; C041; C042
S5	Evaporation pressure	0-5V	Hc45; C037; C038; C039
S6	Not present	-	Hc05; U025; U026; U027
S7	Suction temperature	NTC	Hc47

Tab. 2.bb

☛ **Notice:** the discharge temperature probe is automatically assigned type NTC-HT.

Digital inputs - Master circuit 1

Ref.	Description	Configuration parameters
ID1	User pump flow switch	Hc14; U060
ID2	Compressor 1 overload	Hc15; C035
ID3	High pressure switch	C034
ID4	Not present	Hc06; C035; U059; U058; U062; U057; U061
ID5	Remote alarm	Hc07; C035; U059; U058; U062; U057; U061
ID6	2nd set point	HC08; C035; U059; U058; U062; U057; U061

Tab. 2.bc

Digital inputs - Slave circuit 2

Ref.	Description	Configuration parameters
ID1	Pump 2 overload	Hc16; U061
ID2	Compressor 1 overload	Hc17; C035
ID3	High pressure switch	C034
ID4	Not present	Hc09; C035; U059; U058; U062; U057; U061
ID5	Not present	Hc10; C035; U059; U058; U062; U057; U061
ID6	Not present	Hc11

Tab. 2.bd

Digital outputs - Master circuit 1

Ref.	Description	Configuration param.s
C-NO1	Compressor 1	Hc51; C036
C-NO2	Compressor 2	Hc52; C036
C-NO3	User pump 1	Hc53; U063
C-NO4	Frost protection heater (*)	Hc54; U066; S063; U065
C5-NO5	Alarm	Hc55; U064
C5-NO6	Not used	Hc56

Tab. 2.be

Digital outputs - Slave circuit 2

Ref.	Description	Configuration param.s
C-NO1	Compressor 1	Hc61; C036
C-NO2	Compressor 2	Hc62; C036
C-NO3	User pump 2	Hc63; U063
C-NO4	Frost protection heater (*)	Hc64; U066; S063; U065
C5-NO5	Alarm	Hc65; U064
C6-NO6	Not used	Hc66

Tab. 2.bf

☛ **Notice:** (*) the configuration of the output depends on the type of unit: heat pump (reverse-cycle) => reversing valve; Chiller with free cooling (master only) => FC valve; otherwise => Frost protection heater.

Analogue outputs - Master circuit 1

Ref.	Description	Type	Configuration parameters	Notes
Y1	Modulating/On-Off fan	0-10V	Hc71	FCS1*0/CONVONOFF
Y2	Not used	0-10V	Hc72	

Tab. 2.bg

Analogue outputs - Slave circuit 2

Ref.	Description	Type	Configuration parameters	Notes
Y1	Modulating/On-Off fan	0-10V	Hc81	FCS1*0/CONVONOFF
Y2	Not used	0-10V	Hc82	

Tab. 2.bh

2.13.6 Chillers/heat pumps, BLDC+On/Off compressors and bipolar ExV expansion valve

▲ Important: The black lines refer to the electrical connections, the grey lines the serial connections between controller and options (I/O expansion for the second circuit, EVD EVO and Power+).

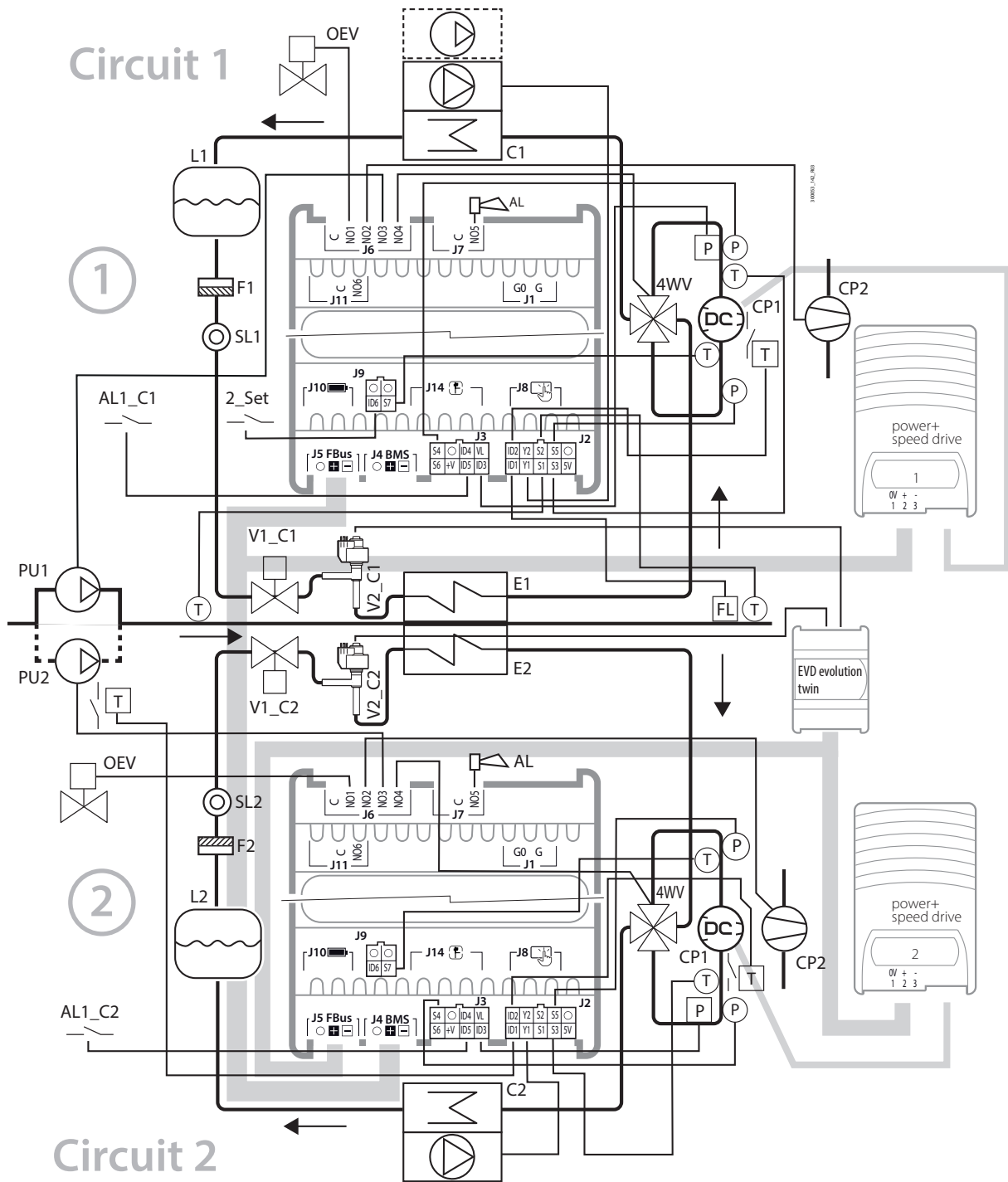

Fig. 2.aa

Ref.	Description
V1_C1	Solenoid valve circuit 1
V1_C2	Solenoid valve circuit 2
V2_C1	Electronic expansion valve circuit 1
V2_C2	Electronic expansion valve circuit 2
P	Pressure probe/pressure switch
T	Temperature probe/thermostat
4WV	Reversing valve

Ref.	Description
PU1/2	User pump 1/2
AL1_C1/2	Remote alarm circuit 1/2
F1/2	Filter-drier 1/2
L1/2	Liquid receiver 1/2
C1/C2	Condenser 1/2
E1/E2	Evaporator 1/2

Ref.	Description
SL1/2	Liquid sightglass 1/2
CP1/2	Compressor 1/2
AL	Alarm
OEV	Oil equalis. valve
2_Set	2nd set point
FL	Flow switch

Tab. 2.bi

Analogue inputs - Master circuit 1

Ref.	Description	Type	Configuration parameters
S1	Return temperature from user	NTC	Hc31
S2	Delivery temperature to user	NTC	Hc32
S3	Discharge temperature	-	Hc00
S4	Condensing pressure	0-5V	Hc34; C040; 041; C042
S5	Evaporation pressure	0-5V	Hc35; C037; C038; C039
S6	Not present	-	Hc03; U025; U026; U027
S7	Suction temperature	NTC	Hc04

Tab. 2.bj

Notice: the discharge temperature probe is automatically assigned type NTC-HT.

Analogue inputs - Slave circuit 2

Ref.	Description	Type	Configuration parameters
S1	Not present	NTC	Hc41
S2	Not present	NTC	Hc42
S3	Discharge temperature	-	Hc00
S4	Condensing pressure	0-5V	Hc44; C040; 041; C042
S5	Evaporation pressure	0-5V	Hc45; C037; C038; C039
S6	Not present	-	Hc05; U025; U026; U027
S7	Suction temperature	NTC	Hc47

Tab. 2.bk

Digital inputs - Master circuit 1

Ref.	Description	Configuration parameters
ID1	User pump flow switch	Hc14; U060
ID2	Compressor 1 overload	Hc15; C035
ID3	High pressure switch	C034
ID4	Not present	Hc06; C035; U059; U058; U062; U057; U061
ID5	Remote alarm	Hc07; C035; U059; U058; U062; U057; U061
ID6	2nd set point	HC08; C035; U059; U058; U062; U057; U061

Tab. 2.bl

Digital inputs - Slave circuit 2

Ref.	Description	Configuration parameters
ID1	Pump 2 overload	Hc16; U061
ID2	Compressor 1 overload	Hc17; C035
ID3	High pressure switch	C034
ID4	Not present	Hc09; C035; U059; U058; U062; U057; U061
ID5	Not present	Hc10; C035; U059; U058; U062; U057; U061
ID6	Not present	Hc11

Tab. 2.bm

Digital outputs - Master circuit 1

Ref.	Description	Configuration parameters
C-NO1	Oil equalisation valve (tandem compressors only)	Hc51; P017
C-NO2	Compressor 2	Hc52; C036
C-NO3	User pump 1	Hc53; U063
C-NO4	Reversing valve (*)	Hc54; U066; S063; U065
C-NO5	Alarm	Hc55; U064
C-NO6	Frost protection heater	Hc56; Hc12

Tab. 2.bn

Digital outputs - Slave circuit 2

Ref.	Description	Configuration parameters
C-NO1	Oil equalisation valve (tandem compressors only)	Hc61; P017
C-NO2	Compressor 2	Hc62; C036
C-NO3	User pump 2	Hc63; U063
C-NO4	Reversing valve (*)	Hc64; U066; S063; U065
C-NO5	Alarm	Hc65
C-NO6	Frost protection heater	Hc66; Hc12

Tab. 2.bo

Notices:

- BLDC compressor driven by Power+ speed drive.
- (*) the configuration of the output depends on the type of unit: heat pump (reverse-cycle) => reversing valve; Chiller with free cooling (master only) => FC valve; otherwise => Frost protection heater.

Analogue outputs - Master circuit 1

Ref.	Description	Type	Configuration parameters	Notes
Y1	Modulating/On-Off fan	0-10V	Hc71	FCS1*0./CONVONOFF
Y2	Not used	0-10V	Hc72	

Tab. 2.bp

Analogue outputs - Slave circuit 2

Ref.	Description	Type	Configuration parameters	Notes
Y1	Modulating/On-Off fan	0-10V	Hc81	FCS1*0./CONVONOFF
Y2	Not used	0-10V	Hc82	

Tab. 2.bq

2.13.7 Chillers/heat pumps, BLDC+On/Off compressors and bipolar ExV expansion valve

▲ Important: The black lines refer to the electrical connections, the grey lines the serial connections between controller and options (I/O expansion for the second circuit, EVD EVO and Power+).

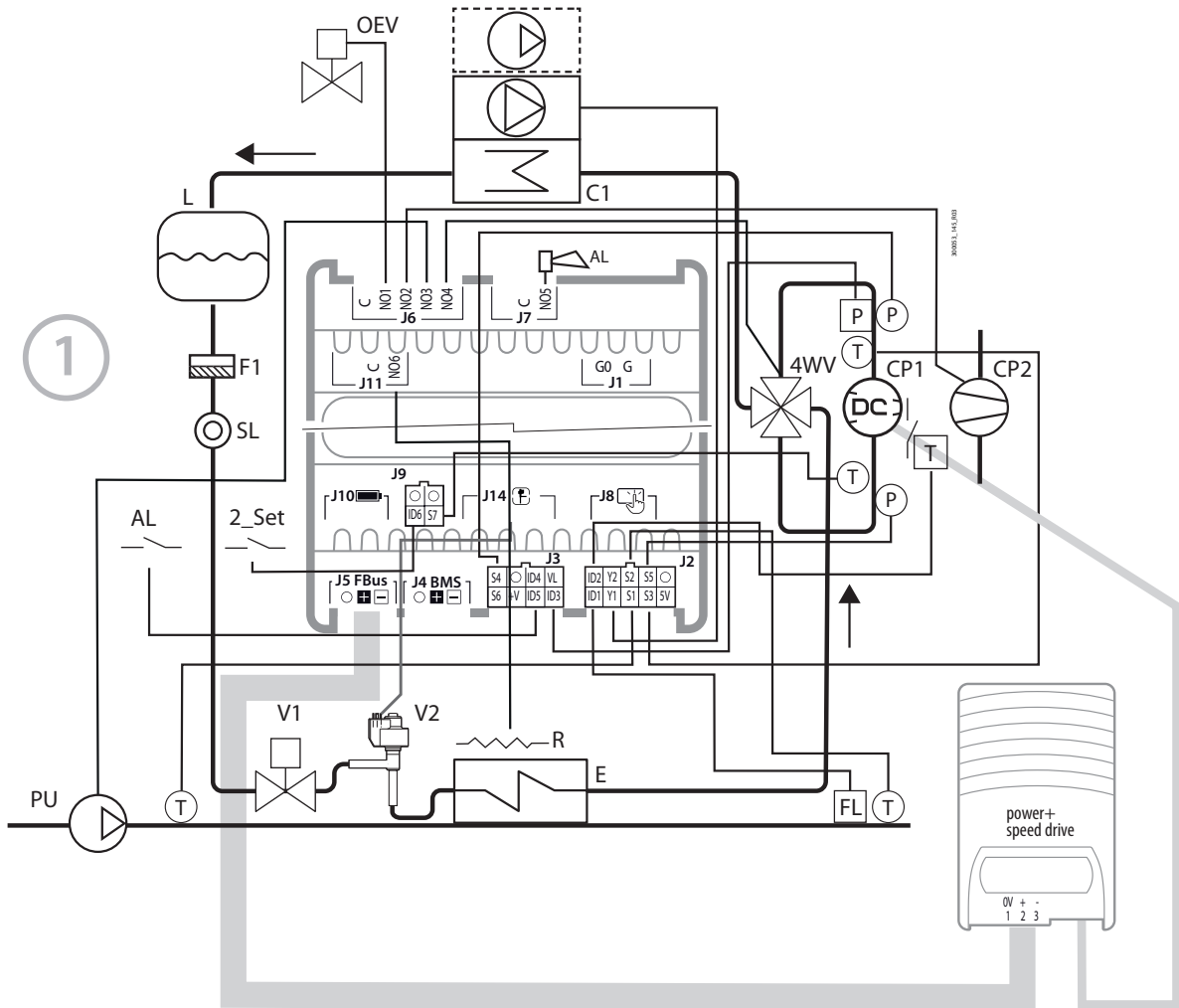

Fig. 2.ab

Ref.	Description
E	Evaporator
4WV	4-way reversing valve
V1	Solenoid valve
V2	Electronic expansion valve
T	Temperature probe/thermostat
OEV	Oil equalisation valve

Ref.	Description
P	Pressure probe/pressure switch
C	Condenser
PU	User pump
SL	Liquid sightglass
2_Set	2nd set point
F1	Filter-drier

Ref.	Description
CP1/2	Compressor 1/2
FL	Flow switch
L	Liquid receiver
AL	Alarm
AL1	Remote alarm

Tab. 2.br

Analogue inputs

Ref.	Description	Type	Configuration parameters
S1	Return temperature from user	NTC	Hc31
S2	Delivery temperature to user	NTC	-Hc32
S3	Discharge temperature	-	Hc00
S4	Condensing pressure	0-5V	Hc34; C040; 041; C042
S5	Evaporation pressure	0-5V	Hc35; C037; C038; C039
S6	Not present	-	Hc03; U025; U026; U027
S7	Suction temperature	NTC	Hc04

Tab. 2.bs

Notice: the discharge temperature probe is automatically assigned type NTC-HT.

Digital inputs

Ref.	Description	Configuration parameters
ID1	User pump flow switch	Hc14; U060
ID2	Compressor 1 overload	Hc15; C035
ID3	High pressure switch	C034
ID4	Not present	Hc06; C035; U059; U058; U062; U057; U061
ID5	Remote alarm	Hc07; C035; U059; U058; U062; U057; U061
ID6	2nd set point	HC08; C035; U059; U058; U062; U057; U061

Tab. 2.bt

Digital outputs

Ref.	Description	Configuration parameters
C-NO1	Oil equalisation valve (tandem compressors only)	Hc51; P017
C-NO2	Compressor 2	Hc52; C036
C-NO3	User pump 1	Hc53; U063
C-NO4	Reversing valve (*)	Hc54; U066; S063; U065
C-NO5	Alarm	Hc55; U064
C-NO6	Frost protection heater	Hc56; Hc12

Tab. 2.bu

Notice: (*) the configuration of the output depends on the type of unit: heat pump (reverse-cycle) => reversing valve; Chiller with free cooling (master only) => FC valve; otherwise => Frost protection heater.

Analogue outputs

Ref.	Description	Type	Configuration parameters	Notes
Y1	Modulating/On-Off fan	0-10V	Hc71	FCS1*0 /CONVONOFF
Y2	Not used	0-10V	Hc72	

Tab. 2.bv

3. INITIAL CONFIGURATION

The μ Chiller user terminal contains a subset of the available control and configuration parameters (see par 4.2).

Consequently, the user terminal cannot be used to configure μ Chiller.

This is done using Applica, an application that is available in two formats:

- Applica mobile (see par 3.1 APPLICA app)
- Applica desktop (see par 3.4 Applica Desktop)

Applica can connect to μ Chiller and access the complete list of configuration parameters.

3.1 APPLICA app

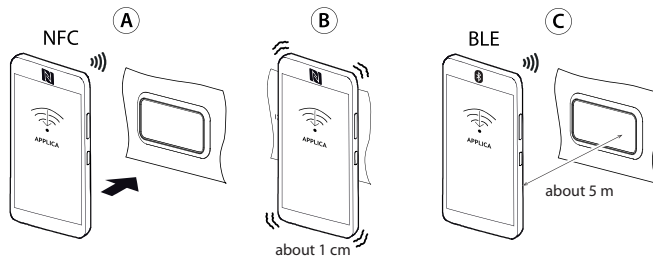

Fig. 3.a

The “Applica” app can be used to configure the controller from a mobile device (smartphone, tablet), via NFC (Near Field Communication) and Bluetooth (BLE). Users can both configure the commissioning parameters and set groups of preset parameters according to specific needs (recipes).

Once the Carel “Applica” app has been installed and opened (see the paragraph “Mobile device”, proceed as follows:

1. For NFC devices, move (A) the mobile device near to the μ Chiller user terminal (the position of the NFC antenna on the mobile device must be identified in order to place it over the display): wait for the signal that the device has been read (B).
2. For Bluetooth devices (C), select the “SCAN BLUETOOTH” option, then choose the device from the list.

Notice: NFC devices use a “retain” (persistent memory) counter, while Bluetooth devices use a RAM (volatile) memory counter. The former is updated every 5 hours, the second every hour.

3.2 Configuration procedure

3.2.1 Step 1 - Set the refrigerant

Standard, Enhanced and Legacy models

1. With Bluetooth devices, access the Service menu by clicking the icon at the bottom right (figure). With NFC devices, the Service menu is already displayed by default (figure below);

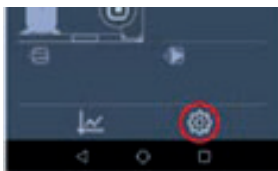

2. click “Set-up”--> “Configurations” --> “Defaults” (figure);
3. select the refrigerant used in the unit;

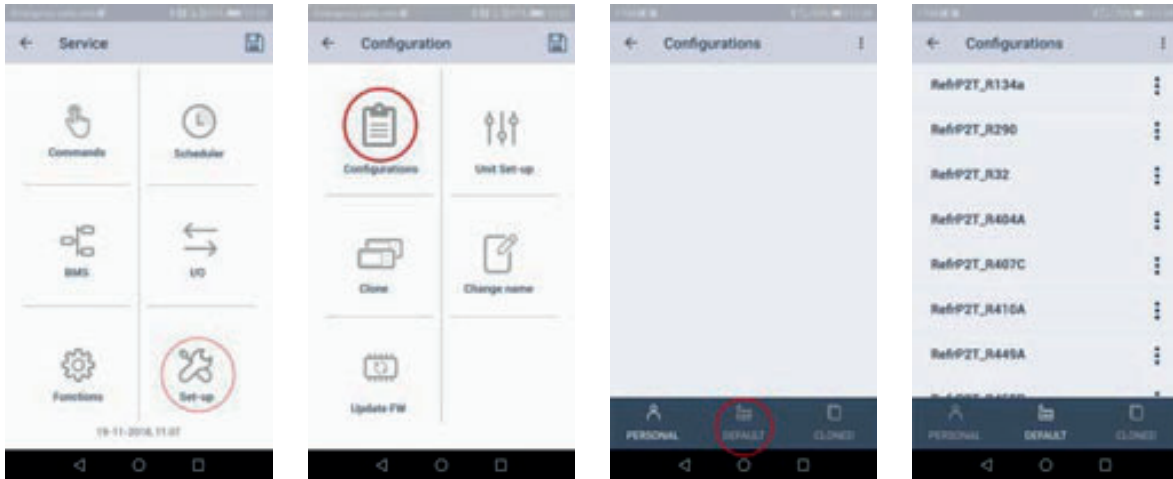

4. apply the selected configuration via NFC or Bluetooth. The refrigerant has now been correctly configured.

High Efficiency model

1. With Bluetooth devices, access the Service menu by clicking the icon at the bottom right (figure). With NFC devices, the Service menu is already displayed by default (figure below);

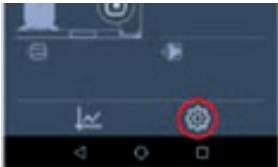
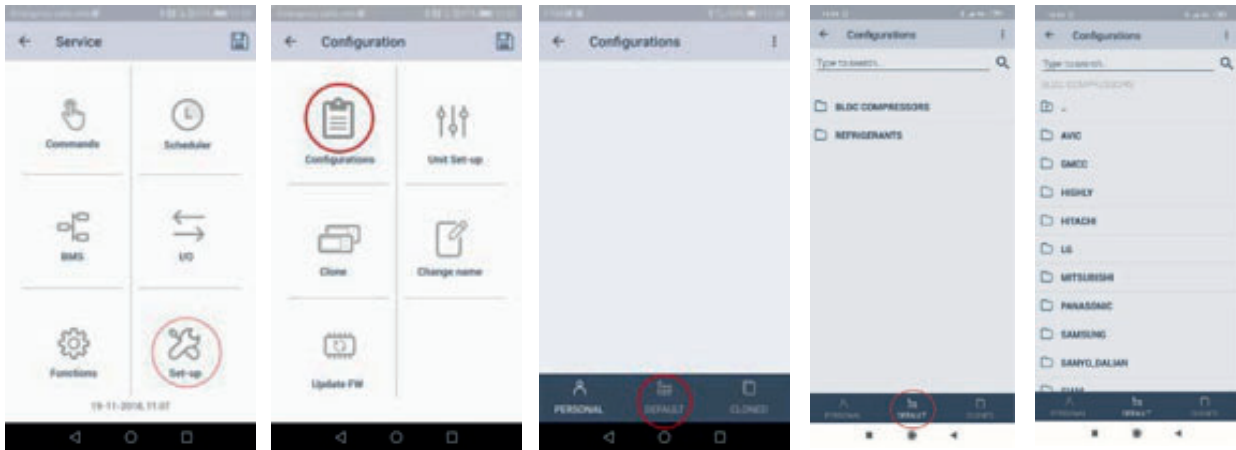

Fig. 3.b

2. click "Set-up"--> "Configurations"--> "Defaults" (figure);
3. select the "BLDC Compressors" folder and then the compressor used on the unit;



4. apply the selected configuration via NFC or Bluetooth. The refrigerant has now been correctly configured.

3.2.2 Step 2 - Configure the unit

1. continue configuring the unit by clicking the "Set-up"--> "Unit setup"--> "Unit configuration". Complete the unit configuration by pressing the PREV / NEXT buttons to scroll through all of the configuration parameter pages;

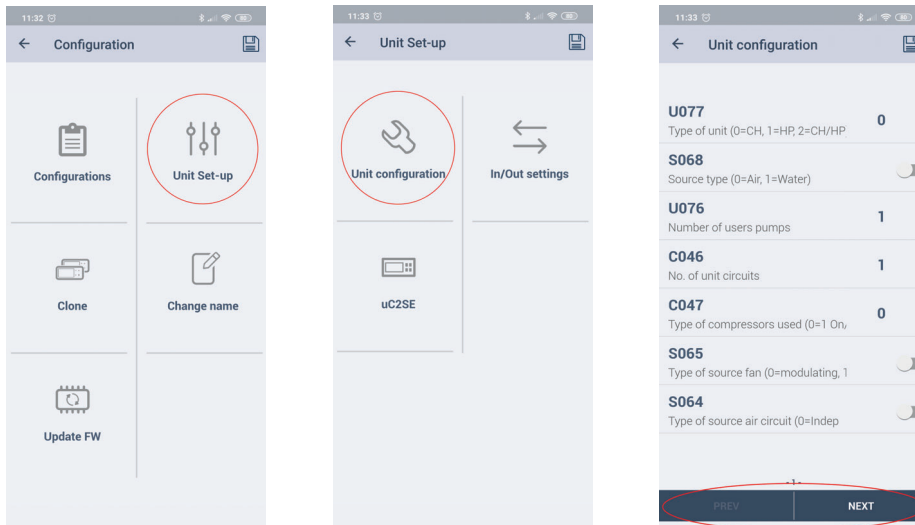

2. apply the parameters configured via NFC / Bluetooth to the controller.

3.2.3 Step 3 - Configure the inputs/outputs

1. click "Set-up"--> "Unit setup"--> "IO configuration". Complete the unit configuration by pressing the PREV / NEXT buttons to scroll through all of the configuration parameter pages;

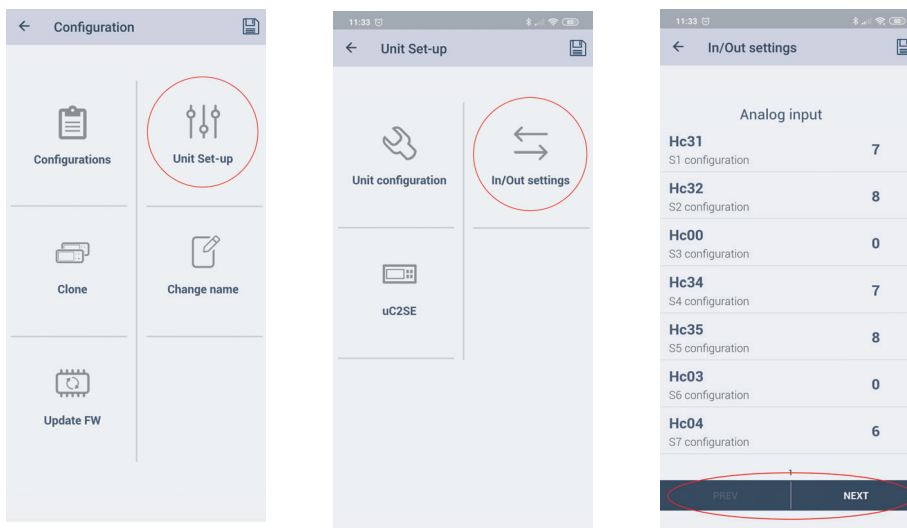

2. apply the parameters configured via NFC / Bluetooth to the controller

3.2.4 Step 4 - Configure parameter compatibility with mCH2 (Legacy model only)

1. click "Set-up"-->"Unit setup"-->"mCH2 parameters" and complete the configuration of the unit

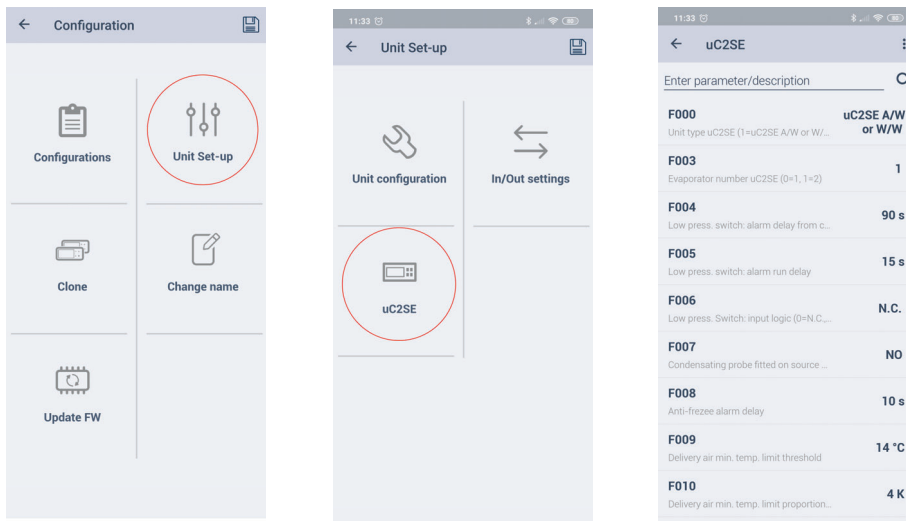

2. apply the parameters configured via NFC / Bluetooth to the controller.

3.2.5 Applica: date and time setting

Applica includes a feature for setting the date and time on μ Chiller in just one simple step, copying the values from the mobile device.

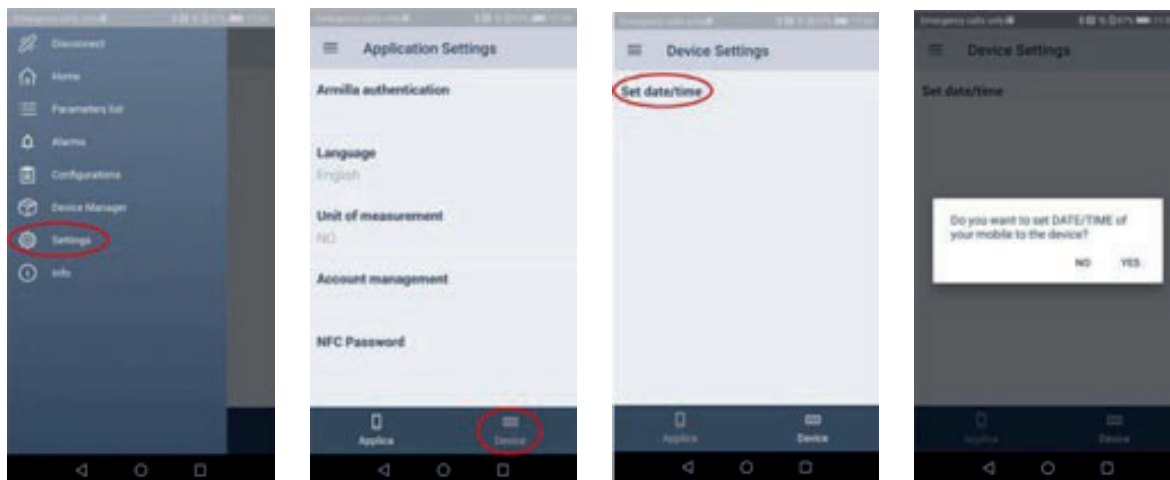

Procedure:

1. open Applica on the mobile device;
2. access the controller via NFC or Bluetooth, entering your profile credentials;
3. access the menu on the command bar at the top left;
4. select "set date/time";
5. confirm;
6. with an NFC connection, move the device near to the user terminal to write the copied values.

Notice: with a Bluetooth connection, the values are copied on confirmation.

3.2.6 Applica: copy configuration

Applica includes a "Clone" feature to acquire the configuration from one unit and replicate it "one-for-one" to other units.

Procedure:

1. open Applica on the mobile device;
2. access the controller via NFC or Bluetooth, using the "Service" or "Manufacturer" profile credentials;
3. follow the path "Configurations/Clone";
4. enter a name to describe the configuration being saved;
5. with an NFC connection: move the device near to the display terminal on the μ Chiller that the configuration is being copied from; once the message shows the configuration has been acquired, this is saved to the smartphone's memory, available via icon 2 (see the following figure);
6. select the saved configuration; (with an NFC connection) move the device near to the display terminal on the μ Chiller that the same configuration is being applied to;
7. confirm and wait for the confirmation message.

📌 **Notice:** with a Bluetooth connection the configuration is saved/applied on confirmation.

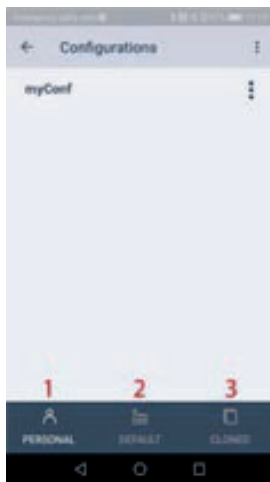

With reference to the previous figure, tapping the icon:

1. accesses the configurations saved by the user;
2. accesses the configurations prepared by Carel;
3. accesses the saved clones.

3.3 Unit set-up parameter list

3.3.1 Unit parameters

📌 **Notice:** follow the order shown in the table to configure the Unit set-up parameters.

Par.	Description	Def.	Min.	Max.	UOM
U077	Type of unit 0=CH; 1=HP; 2=CH/HP; 3=Cooling-only condensing unit; 4=Reverse-cycle condensing unit; 5=Cooling-only air/air; 6=Reverse-cycle air/air/air;	0	0	6	-
S068	Source type (0=Air, 1=Water)	0	0	1	-
U076	Number of system pumps	1	1	2	-
C046	No. of unit circuits	1	1	2	-
C047	Type of compressors used (0=1 On/Off; 1=2 On/Off; 2=1 BLDC; 3=1 BLDC+On/Off)	0	0	1/3	-
S065	Type of source fan (0/1=Modulating/ON-OFF)	0	0	1	-
S064	Type of source air circuit (0=Independent; 1=Common)	0	0	1	-
S072	Source pump activation 0=always on 1=On with compressors on 2=control on condensing temperature	0	0	1	-
E047	ExV driver (0=Disabled; 1=Built-in; 2=EVD Evolution)	0	0	2	-
E046	EVD Evolution: valve (1=CAREL ExV, ..) (*) (*) see EVD Evolution manual for the complete list of selectable valves	1	1	24	-
E020	MOP in cooling: threshold	30.0	-60.0	200.0	°C
E022	MOP in heating: threshold	20.0	-60.0	200.0	°C
C017	Max high pressure threshold (HP)	65.0	0.0	999.9	°C
C018	Min low pressure threshold (LP)	0.2	-99.9	99.9	bar
U068	Free cooling: enable (0/1=no/yes)	0	0	1	-
U074	Free cooling type (0=Air; 1=Remote coil; 2=Water)	0	0	2	-

Par.	Description	Def.	Min.	Max.	UOM
U071	Design free cooling delta T	8.0	0.0	99.9	K
U061	System pump overload: input logic (0/1=NC/NO)	0	0	1	-
U065	Freecooling valve: output logic (0/1=NO/NC)	0	0	1	-
S063	Reversing valve: output logic (0/1=NO/NC)	0	0	1	-
S054	4-way valve: pressure differential for reversing	3.0	0.0	999.9	bar
C049	Low pressure switch alarm delay on compressor activation	90	0	999	-
C050	Low pressure switch alarm delay with compressor on	15	0	999	-
C051	Low pressure switch input logic (0=NC; 1=NA)	0	0	1	-
S053	Defrost synchronisation (0=Independent, 1=Separate, 2=Simultaneous)	0	0	2	-
U006	Cooling set point: minimum limit	5.0	-99.9	999.9	°C
U007	Cooling set point: maximum limit	20.0	-99.9	999.9	°C
U008	Heating set point: minimum limit	30.0	0.0	999.9	°C
U009	Heating set point: maximum limit	45.0	0.0	999.9	°C
Hc13	Buzzer (0/1=No/Yes)	1	0	1	-
U081	High/low pressure and frost alarm reset configuration	7	0	7	-
	0= HP1-2/LP1-2/A1-2/Manual frost protection				
	1= HP1-2/LP1-2/A1-2/Automatic frost protection				
	2= HP1-2/A1-2 Manual frost protection LP1-2 automatic				
	3= HP1-2 manual LP1-2/A1-2 Automatic frost protection				
	4= HP1-2/LP1-2 manual A1-2/Automatic frost protection				
	5= HP1-2/LP1-2 (3 times in an hour) manual; A1-2/Automatic frost protection				
	6= HP1-2/LP1-2 (3 times in an hour) manual; A1-2/Manual frost protection				
	7=HP1-2 manual/LP1-2 (3 times in an hour)/Manual frost protection				

Tab. 3.bw

(*) see EVD Evolution manual for the complete list of selectable valves

3.3.2 I/O configuration

For the description of the following parameters, see chapter 3 of this document

Par.	Description	Def.	Min.	Max.	UOM
HC31	Analogue input 1 configuration Circuit 1	7	0	8	-
HC32	Analogue input 2 configuration Circuit 1	8	0	8	-
HC00	Analogue input 3 configuration Circuit 1	0	0	8	-
HC34	Analogue input 4 configuration Circuit 1	7	0	10	-
HC35	Analogue input 5 configuration Circuit 1	8	0	10	-
HC03	Analogue input 6 configuration Circuit 1	0	0	11	-
HC04	Analogue input 7 configuration Circuit 1	6	0	8	-
HC41	Analogue input 1 configuration Circuit 2	0	0	8	-
HC42	Analogue input 2 configuration Circuit 2	0	0	8	-
HC43	Analogue input 3 configuration Circuit 2	0	0	8	-
HC44	Analogue input 4 configuration Circuit 2	7	0	10	-
HC45	Analogue input 5 configuration Circuit 2	8	0	10	-
HC05	Analogue input 6 configuration Circuit 2	0	0	11	-
HC47	Analogue input 7 configuration Circuit 2	6	0	8	-
HC14	Digital input 1 configuration Circuit 1	1	0	12	-
HC15	Digital input 2 configuration Circuit 1	2	0	12	-
HC06	Digital input 4 configuration Circuit 1	0	0	12	-
HC07	Digital input 5 configuration Circuit 1	7	0	12	-
HC08	Digital input 6 configuration Circuit 1	6	0	12	-
HC16	Digital input 1 configuration Circuit 2	10	0	12	-
HC17	Digital input 2 configuration Circuit 2	2	0	12	-
HC09	Digital input 4 configuration Circuit 2	0	0	12	-
HC10	Digital input 5 configuration - Circuit 2	0	0	12	-
HC11	Digital input 6 configuration Circuit 2	0	0	12	-
HC71	Analogue output 1 configuration Circuit 1	1	0	3	-
HC72	Analogue output 2 configuration Circuit 1	3	0	3	-
HC81	Analogue output 1 configuration Circuit 2	1	0	3	-
HC82	Analogue output 2 configuration Circuit 2	0	0	3	-
HC51	Digital output 1 configuration Circuit 1	1	0	12	-
HC52	Digital output 2 configuration Circuit 1	2	0	12	-
HC53	Digital output 3 configuration Circuit 1	4	0	12	-
HC54	Digital output 4 configuration Circuit 1	7	0	12	-
HC55	Digital output 5 configuration Circuit 1	10	0	12	-
HC56	Digital output 6 configuration Circuit 1	0	0	12	-
HC61	Digital output 1 configuration Circuit 2	1	0	8	-
HC62	Digital output 2 configuration Circuit 2	2	0	8	-
HC63	Digital output 3 configuration Circuit 2	4	0	8	-
HC64	Digital output 4 configuration Circuit 2	7	0	8	-
HC65	Digital output 5 configuration Circuit 2	0	0	8	-
HC66	Digital output 6 configuration Circuit 2	0	0	8	-
C037	Evaporation pressure: probe type (0=0-5V; 1=4-20mA)	0	0	1	-
C038	Evaporation pressure probe: min value	0.0	-1.0	99.9	bar
C039	Evaporation pressure probe: max value	17.3	0.0	99.9	bar

Par.	Description	Def.	Min.	Max.	UOM
C040	Condensing pressure: probe type (0=0-5V; 1=4-20mA)	0	0	1	-
C041	Condensing pressure probe: min value	0.0	-1.0	99.9	bar
C042	Condensing pressure probe: max value	45.0	0.0	99.9	bar

Tab. 3.bx

3.3.3 mCH2 parameters

Par.	Description	Def.	Min.	Max.	UOM
F027	Compressors at part load (0=NO, 1=YES)	0	0	1	-
F003	Number of evaporators (0=1; 1=2)	0	0	1	-
F007	Sensor S4 installed on the source heat exchanger (0=No, 1=Yes: in CH mode reads condensing temp., in HP mode reads evap. temp.)	0	0	1	-
F008	Frost protection alarm delay	10	0	999	-
F009	Supply air temperature limit threshold	14.0	0.0	99.9	°C
F010	Supply air temperature limit diff.	4.0	0.0	20.0	°K
F011	Heater dig. output logic (0=NO; 1=NC)	0	0	1	-
F012	Offset on set point in cooling operation for the heaters	1.0	0.0	99.9	°K
F013	Differential on set point in cooling mode for the heaters	0.5	0.2	99.9	°K
F014	Offset on set point in heating mode for the heaters	3.0	0.0	99.9	°K
F015	Differential on set point in heating mode for the heaters	1.0	0.2	99.9	°K
F016	Heaters active during defrost (0=No, 1=Yes)	0	0	1	-
F017	Supply fan operating mode (0=Always ON; 1=ON by temp. control)	0	0	1	-
F018	Hot-start set point	40.0	0.0	99.9	°C
F019	Hot-keep differential	5.0	0.0	99.9	°K
F020	Compressor request logic from digital input (0=NC; 1=NO)	1	0	1	-
F021	Mixed water outlet temperature probe calibration (S1 expansion)	0.0	-99.9	99.9	°K
F022	Evaporator 2 water outlet temperature probe calibration (S2 expansion)	0.0	-99.9	99.9	°K
F023	Direct relationship between digital inputs and digital outputs for condensing unit (0=No, 1=Yes)	0	0	1	-
F024	Manual heater 1 management (0=AUTO; 1=OFF; 2=ON)	0	0	2	-
F025	Manual heater 2 management (0=AUTO; 1=OFF; 2=ON)	0	0	2	-
F026	Compressors off at low outside temperature (air/air)	-40.0	-40.0	99.9	°C
F027	Enable compressor capacity control 0/1=No/Yes	0	0	1	-
F028	Air heating: probe for user heater temperature control 0=ROOM 1=SUPPLY	0	0	1	-

Tab. 3.by

3.4 Applica Desktop

Applica Desktop is a program intended for manufacturers and installers of units fitted with the µChiller controller. It can be downloaded from ksa.carel.com.

The Applica Desktop offers the possibility to:

- access the controller using the assigned profile;
- create configurations;
- apply configurations;
- clone a unit configuration, i.e. copy all of the unit's parameter values;
- complete the commissioning procedure;
- troubleshoot any problems on the unit.

Notice:

- Applica Desktop can be used as an alternative to the Applica app, and requires an internet connection;
- For the physical connection to the BMS port on µChiller, use the USB/RS485 converter P/N CVSTDUMORO

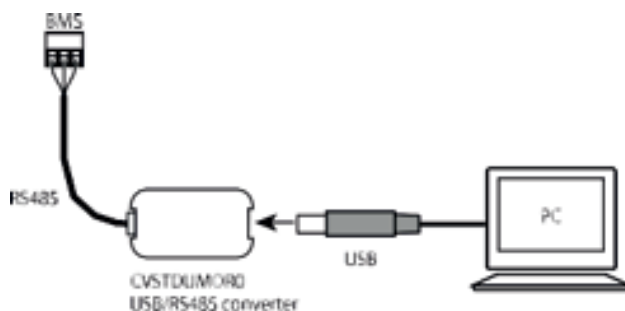
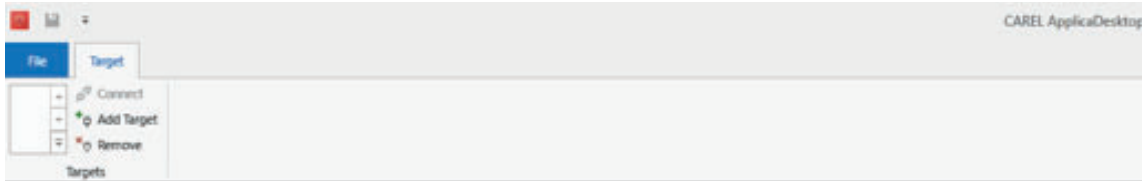

Fig. 3.c

3.4.1 Preparing for operation

1. Access KSA, "Software & Support", "µChiller" section.
2. Select the "Configurations" folder.
3. For µChiller Standard, Enhanced and Legacy models (with On/Off compressor), select the "Refrigerants" section and then the refrigerant charged on the unit.
4. Connect to the BMS port on the µChiller controller, as shown in Figure 5.b;
5. Open Applica Desktop; a window will be opened with the right part of the top bar as shown below:



6. Select "Add target" and assign it a meaningful name (e.g.
7. In the "COM Port" field, enter the COM port used for the USB connection to the USB/RS485 converter;
8. Configure the connection parameters (Baudrate=115200, Bits=8, Parity=None, Stop Bits=Two, Serial Node=1) as shown in the figure (the data are saved automatically);
9. Use "Connect" to connect to the µChiller (which must be powered on).

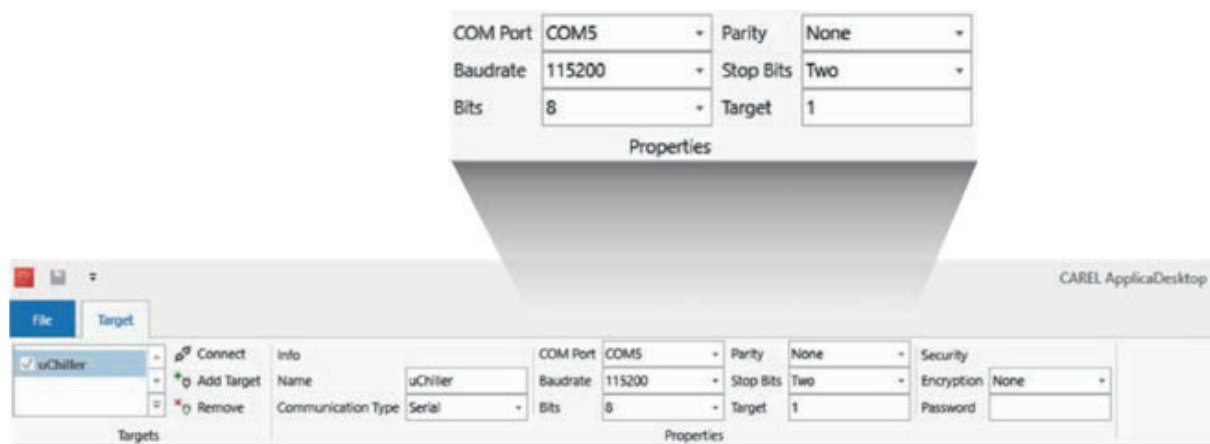

3.5 Configuration procedure with Applica Desktop - Legacy Model

3.5.1 Step 1 - Set the refrigerant

Once connected, select the "Configurations" label: the command bar will be displayed, as shown:

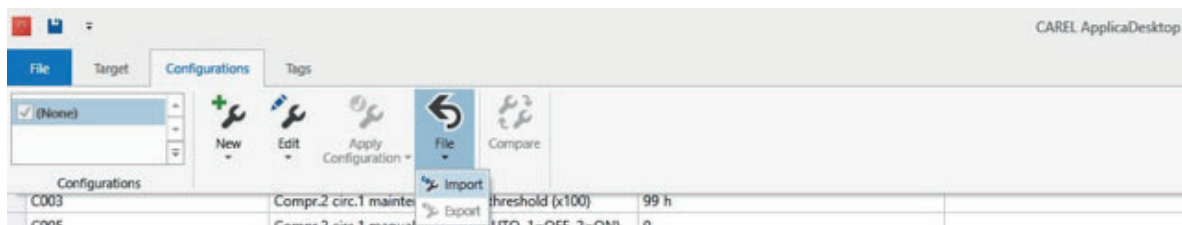

1. Select "File -> Import" to load the refrigerant configurations downloaded from KSA;
2. Select the configuration to be applied to the µChiller, and then "Apply Configuration";

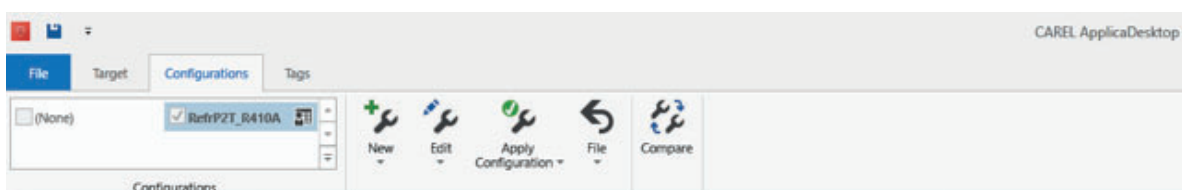

3. Applica Desktop will display a message when the parameters have been set, and if necessary indicating any values that have been applied that do not belong to the current user profile (some parameters may not be visible to the user).

3.5.2 Step 2 - Configure µChiller

1. Select the "Configurations" label, select "New -> New configuration" and assign a name to the new configuration being created.

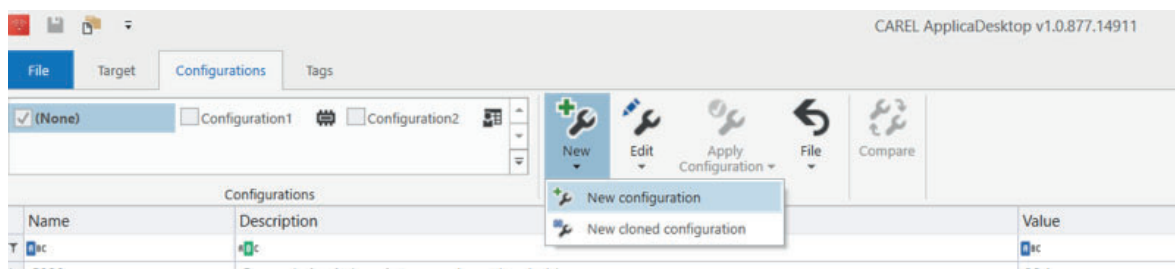

2. Select the newly created configuration
3. Select "Edit -> Apply Live Values". This operation copies the values of the parameters currently saved on the connected µChiller to the newly created configuration.

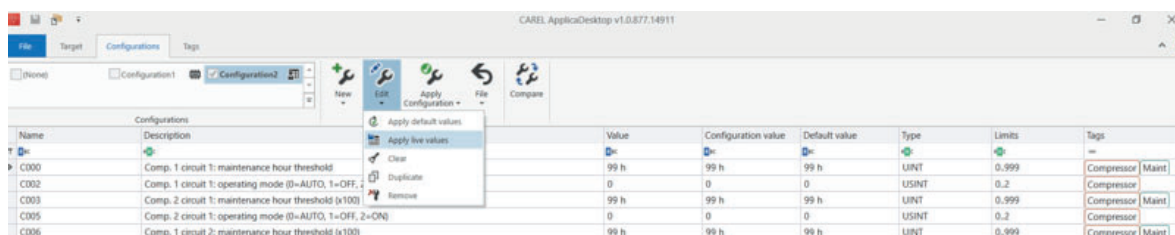

4. Select the "Tags" label and then the "Unit_Cfg" command
5. Change the parameters listed in the "Configuration value" column to configure the unit

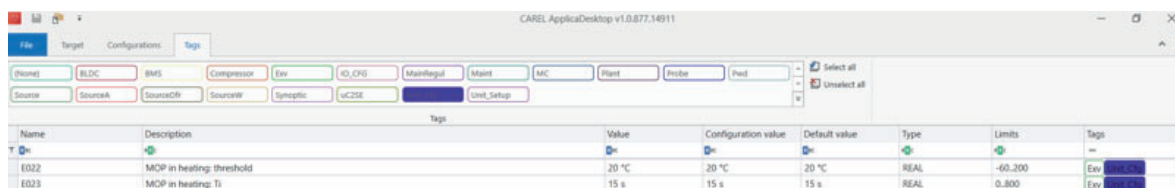

6. Repeat the same steps for the "IO_CFG" and "uCH2SE" tags.
7. The unit has now been configured. If desired, the control parameters can be modified using the other tags available as search filters.
8. Once all of the desired parameters have been changed, to apply the changes select the "Configuration" label and select "Apply Configuration"

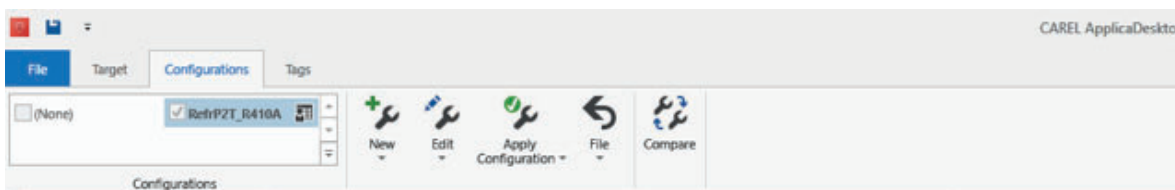

Finally, to save the newly-created configuration for future use, from the “Configurations” label select “File -> Export” and assign a name to the configuration being saved.

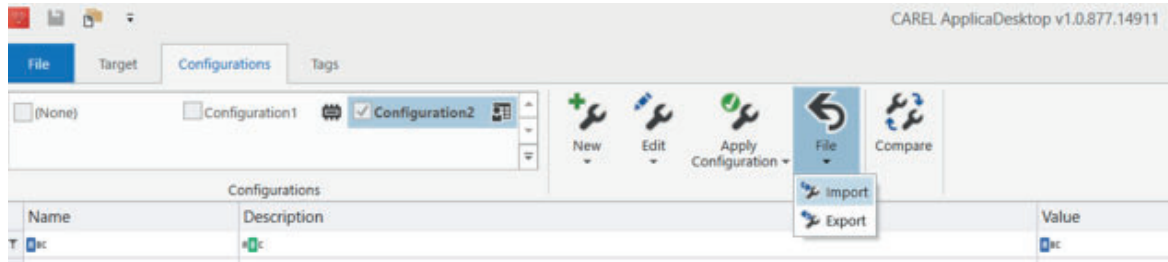

3.5.3 Applica Desktop: date and time setting

Applica Desktop can set the date and time on μ Chiller in just one simple step, copying the values from the PC to the controller.

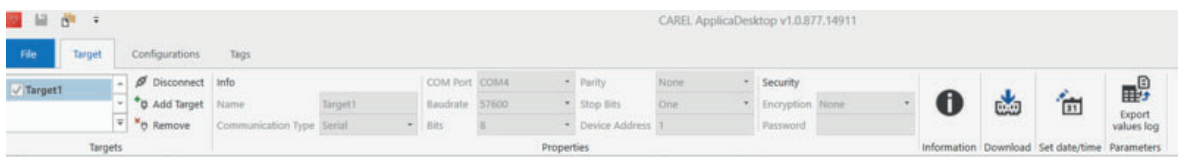

Procedure:

1. Once connected, select “Set date&time”;
2. In the pop-up window, confirm synchronisation of the time and date on μ Chiller with the PC

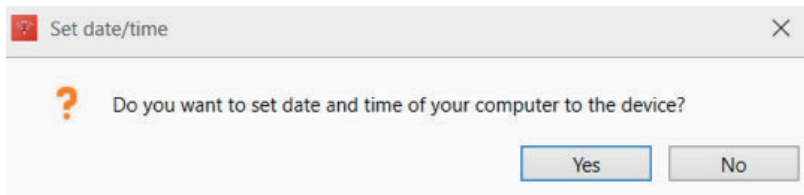

4. USER INTERFACE

4.1 Introduction

µChiller uses the user terminal to display the alarms, the main variables and to set the unit set points (User level) and manual functions (Service level). The terminal has a 7-segment LED display with two rows: the top row is 3-digit plus sign and decimal point; the bottom row is 4-digit plus sign (this can also display the hour format -hh:mm and date - MM:DD). There is a buzzer, 14 operating icons and 4 buttons for scrolling and setting the parameters. The terminal has NFC (Near Field Communication) and Bluetooth (depending on the model) connectivity for interaction with mobile devices (on which the Carel "Applica" app has been installed, available on Google Play for the Android operating system).

Note: access levels: U=User; S=Service; M=Manufacturer. See the parameter table.

The unit of measure on the display can be changed via parameter UoM, accessed at a Service level, including in the direct access functions menu.

Code	Description	Def.	UoM	Min	Max	Lev.
UoM	Unit of measure 0=°C/barg - 1=°F/psig	0	-	0	1	S

Tab. 4.a

The information and parameters accessible from the terminal and from the Applica app depend on the access level and the unit configuration parameters.

4.2 User terminal

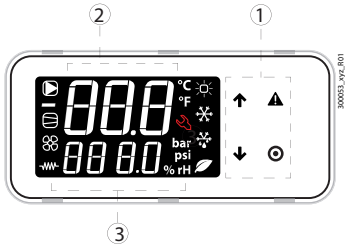

Key:

1	Keypad
2	Main field
3	Device status and operating mode icons

Fig. 4.a

Note: the user terminal only allows access to certain parameters at the User and Service levels: to access all of the Service and Manufacturer parameters, use the Carel Applica app or the configuration and commissioning tool.

4.2.1 Keypad

Button	Description	Function
↑	UP	<ul style="list-style-type: none"> When scrolling: go to the previous parameter In programming mode: increase the value
↓	DOWN	<ul style="list-style-type: none"> When scrolling: go to the next parameter In programming mode: decrease in value
⚠	Alarm	Main menu: <ul style="list-style-type: none"> pressed briefly: unit dashboard display pressed and held (3 s): access User parameters (set point, unit on-off, ...)
⦿	PRG	<ul style="list-style-type: none"> Pressed briefly: display active alarms and mute buzzer Pressed and held (3 s): reset alarms. When scrolling: access parameter programming mode
		In programming mode: <ul style="list-style-type: none"> pressed briefly: confirm value pressed and held (3 s): return to the main menu

Tab. 4.b

4.2.2 Icons

The icons indicate the device operating status and operating modes, as shown in the following table.

Icon	Function	On	Flashing
	System pump	Active	In manual operation
	Source device status (pump/fan)	Active	In manual operation
	Compressor status	Active	In manual operation (with ExV)
	Frost protection heater	Active	-
	Operating mode	Heating	-
		Cooling	High water temperature
		Defrost	Dripping after defrosting
		Free cooling	-
	Service	Service request on exceeding operating hours	Serious alarm, action required by qualified personnel

Tab. 4.c

4.3 Standard display

At start-up, the user terminal briefly shows "NFC", indicating that the NFC interface is available on the user terminal for communication with mobile devices, and then the standard display is shown. The standard display shows:

- on the top row: the delivery water temperature;
- on the bottom row, when the unit is on, the return water temperature; when the unit is off, it shows "OFF".

Note: "bLE" flashes on the display during "Bluetooth" communication.

4.3.1 Dashboard

From the main menu, press DOWN to access information on the status of the devices and the temperatures, superheat values, etc. for the two circuits:

- unit "OFF" and the reason for shutdown:
 - "diSP" from keypad;
 - "dl" from remote contact (via digital input);
 - "Schd" from time band (scheduler);
 - "bMS" from BMS;
 - "ChnG" from operating mode changeover (heating/cooling);
 - "AlrM" from alarm.
- "CMP" compressors;
- "AFC1" source water delivery temperature circuit 1;
- "AFC2" source water delivery temperature circuit 2;
- "EuP1" evaporation temperature circuit 1;
- "SSH1" superheat circuit 1;
- "Cnd1" condensing temperature circuit 1;
- "dSt1" BLDC compressor discharge temperature circuit 1;
- "EuP2" evaporation temperature circuit 2;
- "SSH2" superheat circuit 2;
- "Cnd2" condensing temperature circuit 2;
- "dSt2" BLDC compressor discharge temperature circuit 2; and if the access level is "Service":
- "Hd00" supervisor address (BMS);

and if the access level is "Service":

- "Hd01" BMS baud rate;
- "Hd02" BMS communication parameters;
- "ESC" to exit the dashboard.

Example



Go to the standard display.



Press DOWN: CMP indicates that compressor 1 is on (o) and compressor 2 is off (L).

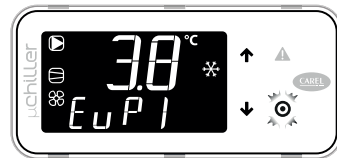

Press DOWN: EuP1 indicates the evaporation temperature in circuit 1 (3.8°C).

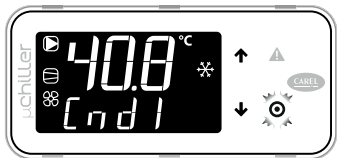

Press DOWN: Cnd1 indicates the condensing temperature in circuit 1 (40.8°C).



To return to the standard display, press PRG (corresponding to ESC).

4.3.2 Direct access functions

The user terminal only provides access to the basic configuration parameters, such as direct functions and active alarms without password protection, or, with password protection, to the parameters used to configure and optimise the unit.

Press DOWN for 3 s to access the direct access functions:

- set point;
- switching unit on and off;
- change operating mode (cooling/heating, only on reverse-cycle units);
- select unit of measure.

In programming mode, the bottom row shows the parameter code, and the top row shows the value.

Procedure

Press:

- DOWN for 3 s to access the parameters (User level, no password required);
- UP and DOWN to scroll and set the parameters;
- PRG to change the parameter value and save the changes;
- PRG (3 s) or ESC to return to the standard display.



1. Go to the standard display

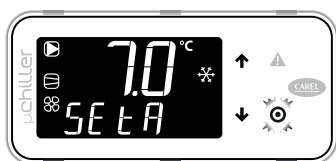

2. Press DOWN for 3 s: the current set point (SEtA) is shown - read-only

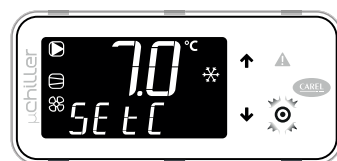

3. Press DOWN: the cooling set point (SEtC) is shown

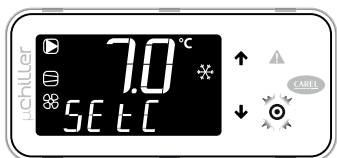

4. Press PRG: the value flashes; press UP/DOWN to change the value; PRG to confirm.



5. Press DOWN: the heating set point (SEtH) is shown - for heat pump units only.



6. Press DOWN: the unit ON/OFF function (UnSt) is shown.

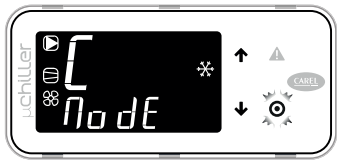

7. Press DOWN: the function for switching from cooling (C) to heating (H) mode (ModE) is shown - for heat pump units only.



8. Press DOWN: the manual defrost function (dFr) is shown - Service level and reverse-cycle A/W units only.

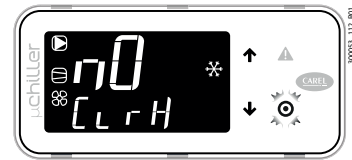

9. Press DOWN: the function to delete the alarm log (ClrH) is shown - Service level only.

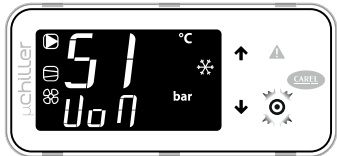

10. Press DOWN: the unit of measure selection (UoM) is shown



11. After having completed the settings, to exit either:
 - from the categories press ESC and then PRG;
 - press PRG for 3 s

4.3.3 Programming mode

Go to the standard display and press PRG to enter programming mode.

Procedure

Press:

- PRG to access the parameters with password protection;
- UP and DOWN to scroll and set the parameters;
- PRG to change the parameter value and save the changes;
- PRG (3 s) or ESC to return to the standard display.



1. Go to the standard display

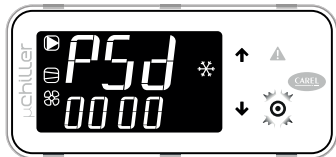

2. Press PRG: the password prompt (PSd) is shown

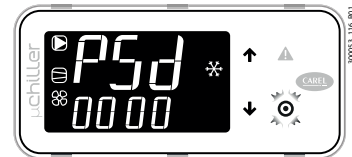

3. Press PRG: the first digit of the password flashes; set the value, press PRG. The second digit now flashes; enter the other digits to complete the password.



4. Press PRG: if the password is correct, the first parameter category is shown: PLt (= system)



5. Press PRG: the first parameter is shown: U002 (Pump 1 manual control)



6. Press PRG: the value flashes; press UP/DOWN to change the value; PRG to confirm.



7. Press UP/DOWN to display the other parameters.



Note: User password: 1000; Service password: 2000; Manufacturer password: 1234. See the parameter table.

4.3.4 Programming menu



Category PLt (system): identified by code Uxxx, these parameters all relate to control and management of the system units.



Category EEV (ExV valve): identified by code Exxx, these parameters all relate to control and management of the electronic expansion valve (s).



Category CMP (compressors): identified by code Cxxx, these parameters all relate to control and management of the compressors and refrigerant circuits.



Category Src (source): identified by code Sxx, these parameters all relate to control and management of the condenser / source.



Category CLc (Clock): identified by code Hxxx, these are the parameter for setting the date/time.



Category Hst (Alarm log): access the alarm log. Each event is described with the date (in the format DD MM) and time (in the format hh:mm) alternating.



Use Log- Out to exit the category.



Use ESC to return to the standard display.

► Notes:

- the Service password also accesses the User parameters;
- if no button is pressed, after around 3 minutes the terminal will automatically return to the standard display.

5. FUNCTIONS

5.1 Temperature control

µChiller can control either the unit's return or delivery water temperature. The return (from user) and delivery (to user) water temperature probes can be installed on any of the channels. See the Installation chapter.

5.1.1 PID control

Two types of PID control are available:

- PID control at start-up;
- PID control in operation.

For each type of PID control, the following parameters can be set:

- Control probe (return or delivery);
- Proportional gain (Kp);
- Integral time (action disabled when time set to 0);
- Derivative time (action disabled when time set to 0).

The control set point and the operating mode (heating / cooling) are the same for both control types:

- control at start-up is aimed at preventing excess capacity being called. Indeed, as when starting the exact status of the units (loads) is not known, but rather only the temperature, capacity needs to be delivered gradually, awaiting the reaction from the system. Control can be applied to the water return temperature, using a low gain and a sufficiently high integral time, greater than the system time constant (120- 180 s, considering a system time constant of at least 60 s, corresponding to a minimum water content of 2.5 l/kW).
- control in operation needs to be more reactive, so as to respond quickly to any variations in load and keep the delivery water temperature as close as possible to the set point. In this case, the time constant depends on the response of the compressor-evaporator system, and is in the order of a few tens of seconds (slower with tube bundle evaporators, faster with plate evaporators).

The following table shows the recommended values (to be calibrated if necessary during system commissioning), according to the type of evaporator used

Code	Description	Evaporator	
		Tube bundle	Plate
U036	Control probe at start-up - 0=Return 1=Delivery	Return	Return
U039	PID at start-up: Kp	6.0	6.0
U040	PID at start-up: Ti - 0: integral action disabled	180 s	180 s
U041	PID at start-up: Td - 0: derivative action disabled	0 s	0 s
U038	Control probe in operation - 0=Return 1=Delivery	Delivery	Delivery
U042	PID in operation: Kp	10.0	10.0
U043	PID in operation: Ti - 0: integral action disabled	120 s	120 s
U044	PID in operation: Td - 0: derivative action disabled	3 s	3 s

Tab. 5.a

The control sequence is as follows:

1. when the unit is Off, both PID controls are disabled;
2. when the unit starts, following the set user pump – compressor delay, the PID at start-up is enabled and generates a capacity request (percentage) that is then processed so as to activate the compressors;
3. if this request is sufficient, one compressor will be started;
4. once the compressor has started, after a set time, control switches from PID at start-up to PID in operation;
5. when the controller requests deactivation of the compressors, these are enabled to stop;
6. after the last compressor has been stopped, restart is managed using the PID at start-up.

If the delay between PID at start-up/in operation is set to 0, PID control in operation will always be active.

User	Code	Description	Def	Min	Max	UOM
S	U047	Compressor activation delay after user pump	30	0	999	s
S	U037	PID control delay at start-up/operation	180	0	999	s

Tab. 5.b

5.1.2 Proportional control

If the desired control is only proportional to the water outlet or return temperature, consider the relationship:

$$K_p = 100/BP$$

For example, to have a proportional band of 2K, set the value of Kp to 50.

The following are the parameter settings required to control the return temperature:

User	Cod.	Description	Setting	UOM	Note
S	U036	Control probe at start-up - 0=Return 1=Delivery	0	-	-
S	U037	PID control delay at start-up/operation	180	s	Not significant
S	U038	Control probe in operation - 0=Return 1=Delivery	0	-	-
S	U039	PID at start-up: Kp	50.0	-	=> Proportional band = 2K
			34.0	-	=> Proportional band = 3K
			25.0	-	=> Proportional band = 4K
			20.0	-	=> Proportional band = 5K
S	U040	PID at start-up: Ti - 0: integral action disabled	0	s	
S	U041	PID at start-up: Td - 0: derivative action disabled	0	s	
S	U042	PID in operation: Kp	=U039	s	Same as Kp at start-up
S	U043	PID in operation: Ti - 0: integral action disabled	0	s	
S	U044	PID in operation: Td - 0: derivative action disabled	0	s	

Tab. 5.c

5.1.3 Set point compensation

µChiller adjusts the set point based on the outside temperature.

Notice: this function can only be enabled if the outside temperature probe is fitted.

The compensation (positive or negative) is determined by:

1. start compensation start (in cooling/heating);
2. end compensation threshold (in cooling/heating);
3. maximum compensation value (in cooling/heating).

User	Code	Description	Def	Min	Max	UOM
S	U010	Enable set point compensation: 0/1=no/yes	0	0	1	-
U	SEtC	Cooling set point	7.0	U006	U007	°C/°F
S	U011	Cooling compensation: start	25.0	-99.9	999.9	°C
S	U012	Cooling compensation: end	35.0	-99.9	999.9	°C
S	U013	Cooling compensation: maximum value	5.0	-99.9	999.9	K
U	SEtH	Heating set point	40.0	U008	U009	°C/°F
S	U014	Heating compensation: start	5.0	-99.9	999.9	°C
S	U015	Heating compensation: end	-10	-99.9	999.9	°C
S	U016	Heating compensation: maximum value	5.0	-99.9	999.9	K

Compensation in cooling:

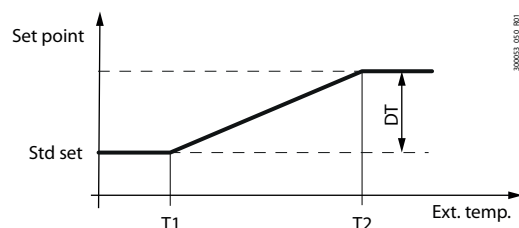

Fig. 5.a

Key

Ext. Temp.	Outside temperature
Std set	Control set point
T1	Outside temperature to start compensation in cooling mode
T2	Outside temperature to end compensation in cooling mode
DT	Maximum compensation value in cooling mode

Compensation in heating:

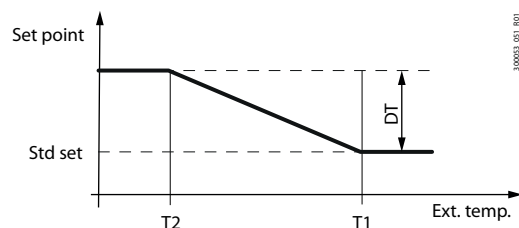

Fig. 5.b

Key

Ext. Temp.	Outside temperature
Std set	Control set point
T1	Outside temperature to start compensation in heating mode
T2	Outside temperature to end compensation in heating mode
DT	Maximum compensation value in heating mode

5.1.4 Request from BMS

The request can be managed directly from a BMS, bypassing normal temperature control and enabling the external request signal (0-100.0%) via the specific Modbus serial variable (BMS_PwrReq, HR 331). This operation is enabled via another serial variable (En_BMS_PwrReq, CS 22).

🔑 **Note:** if the supervisor is offline, the unit continues to operated in stand-alone mode, regardless of the request from the BMS.

5.1.5 High evaporator outlet temperature alarm

µChiller activates an alarm when the evaporator outlet temperature exceeds the threshold set by the user (via the offset relative to the control set point). When the outlet temperature exceeds the threshold, a counter starts and after a delay (settable), the alarm is activated. An initial delay disables the alarm in the transient period when the unit is starting.

🔑 **Notes:**

- the alarm is only available on chiller units.
- the high temperature alarm can be used to activate a backup unit in critical applications.

User	Code	Description	Def	Min	Max	UOM
U	SetA	Current set point	-	-999.9	999.9	°C
S	U031	High water temperature alarm: offset	10.0	0.0	99.9	K
S	U032	High water temperature alarm: delay at start-up	15	0	99	min
S	U033	High water temperature alarm: delay in operation	180	0	999	s

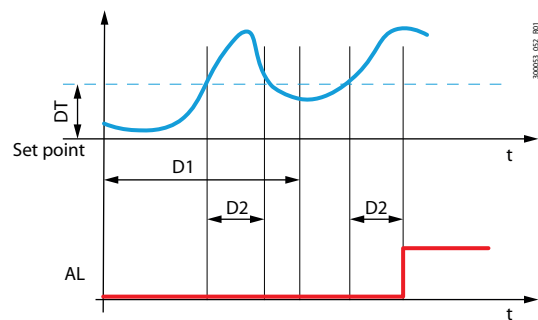

Key

Set point	Current set point
DT	Offset
D1	Delay at start-up
D2	Delay in steady operation
AL	Alarm

Fig. 5.c

5.2 User pumps

µChiller can manage up to two user- side pumps (depending on the hardware used and the required configuration).

A delay can be set between pump and compressor activation (= temperature control enabled). A delay can also be set between the deactivation of the last compressor and the pump. If when the unit shuts down the compressors have been shutdown for at least the "user pump shutdown delay after compressor", then the pump is stopped immediately.

User	Code	Description	Def	Min	Max	UOM
S	U047	Compressor activation delay after user pump	30	0	999	s
S	U048	User pump shutdown delay after compressor	180	0	999	s

Tab. 5.d

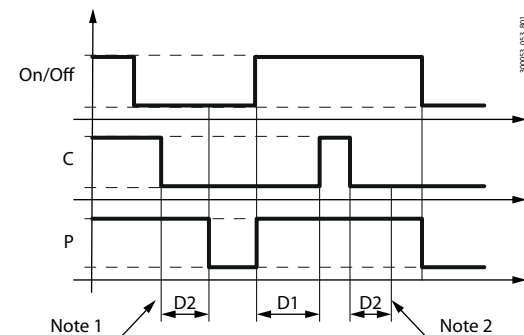

Key

Unit	Unit On-Off (local or remote control)
C	Compressor
P	User pump
D1	Compressor activation delay after user pump
D2	User pump shutdown delay after compressor
Note 1	Control is not active: the compressors are stopped based on their own safety times
Note 2	In this case, the pump can stop immediately

Fig. 5.d

Below is a diagram that represents operation for the configuration with one pump only:

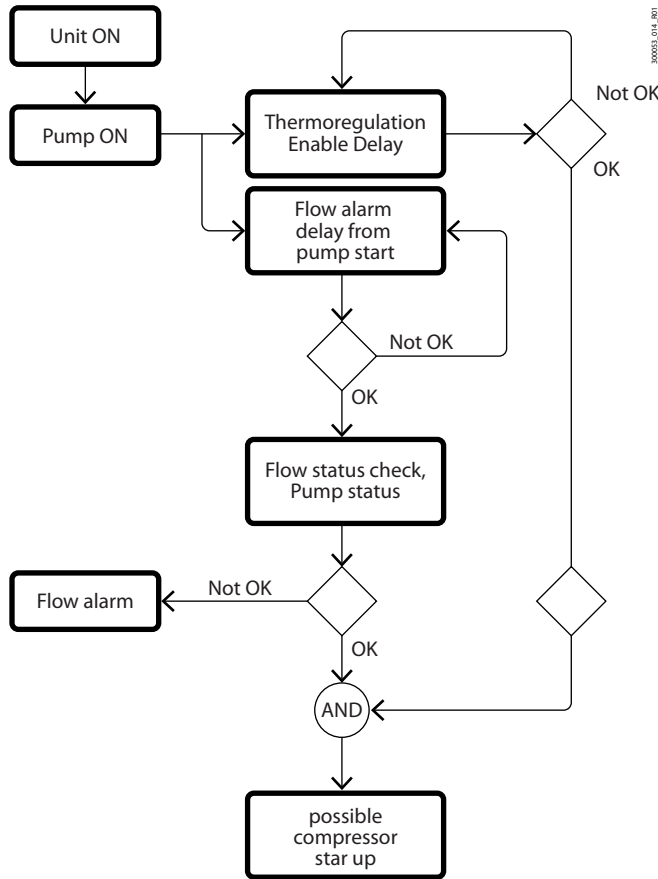

Fig. 5.e

Temperature control is enabled only after the flow alarm delay from pump on, so as to prevent the compressors from starting if there is no fluid flow.

Depending on the configuration, up to two user pumps can be enabled. µChiller includes the following features:

- with two pumps, automatic rotation to ensure fluid circulation and equalisation of operating hours. Rotation is performed:
 - at the end of a period that can be set, in hours;
 - when there is an overload alarm on the active pump.
- management of the pump overload alarm (if available, depending on the controller and configuration). Fault signal and immediate pump deactivation.
- Management of a flow switch that monitors fluid circulation in the system.
- frost protection with unit off: the pump is started so as to activate fluid circulation (when the unit is on, the function is disabled).
- pump anti-blocking: if the pump is off for more than a week, it is activated for 3 seconds.

User	Code	Description	Def	Min	Max	UOM
S	U049	User pump rotation time	12	0	999	h

5.2.1 Cyclical pump activation during standby

When the chiller serves a chilled water tank (for example, in winemaking applications), the pump does not need to keep running, consequently energy can be saved by stopping the pump when the cooling demand is met. Control is only calculated when the pump is on. A function can be activated to:

- switch the pump off after the compressors are stopped by the temperature controller;
- activate the pump periodically, in order to reactivate the compressors and satisfy demand from the units.

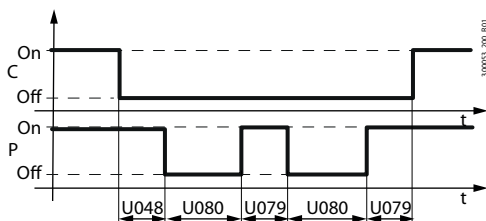

Fig. 5.f

User	Code	Description	Def	Min	Max	UOM
S	U078	Unit pump in standby: enable On-Off cycles	0	0	1	-
S	U079	Unit pump in standby: On time	3	1	15	min
S	U080	Unit pump in standby: Off time	15	3	99	min

Tab. 5.e

5.3 Frost protection control

Two frost protection control modes are available:

1. using the evaporation pressure probe, which directly monitors the conditions of the evaporator
2. using the water temperature probe to monitor the delivery water temperature or the source water temperature on water/ water units in heating mode).

User	Code	Description	Def	Min	Max	UOM
S	U082	Antifreeze controller type 0 = Evaporation temperature 1 = Water temperature	0	0	1	-

5.3.1 Frost protection alarm

When there is a frost alarm on the evaporator, the corresponding circuit is shut down. Each circuit manages its own evaporation pressure probe, and consequently also the frost protection alarm. The evaporation temperature value is filtered based on an exponential distribution formula that takes into consideration the thermal mass of the evaporator so as to avoid false alarms at start-up. A specific algorithm uses this filtered value and activates the alarm if the frost protection threshold is exceeded.

The frost protection alarm reset is set using parameter U081 (see par. 8.1 for further details).

If desired, the frost protection alarm can be set as automatic reset: this means the alarm signal will be cancelled automatically if the alarm condition is no longer present.

If an evaporation temperature probe is configured, frost protection control will automatically use this probe reading, even if a suction pressure probe is available. If only the suction pressure probe is available, then frost protection control will use the temperature converted from the pressure reading.

User	Code	Description	Def	Min	Max	UOM
S	U050	User side frost protection: alarm threshold	-0.8	-99.9	999.9	°C
S	U051	User side frost protection: differential	30.0	0.0	999.9	K
S	U052	User-side frost protection: delay time at 1K	30	0	999	s

The figure shows the action of the filter on the evaporation temperature, according to the exponential distribution formula.

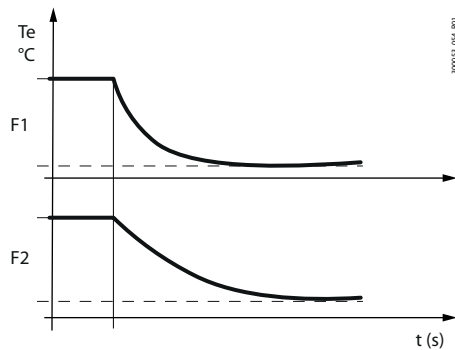

Key

Te	Filtered evaporation temperature
F1	Filter with low delay
F2	Filter with high delay

Fig. 5.g

When the filtered evaporation temperature falls below the alarm threshold, a counter is activated, and the counter time-out is either increased or decreased based on the deviation of the evaporation temperature from the frost protection threshold, until reaching zero when the deviation from the threshold it is greater than the differential, following a hyperbolic trend. This trend imitates the actual behaviour of ice formation and ensures better protection. The following diagram shows the trend in the alarm delay time according to the deviation from the alarm threshold, using the following values: delay time at 1K=60s; differential=30K. At the threshold the delay is equal to 10 times the set value (600s in the example).

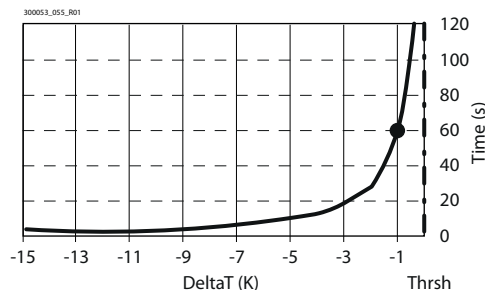

Key

Time [s]	Frost protection alarm delay
ThrsH	Frost protection alarm threshold
DeltaT [K]	Deviation from the frost protection alarm threshold

Fig. 5.h

Frost protection alarm operation:

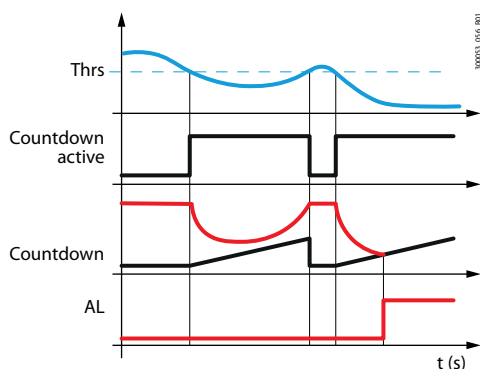

Key

t [s]	Time [s]
Thrs	Frost protection alarm threshold
AL	Frost protection alarm

Fig. 5.i

The value of the delay (at 1K) in the previous example refers to a plate evaporator; if a tube bundle evaporator is used, which has greater thermal inertia, the delay time (at 1K) can be increased to a suitable value. The following table shows the recommended values for the alarm threshold (with pure water), differential and delay, according to the type of evaporator used.

Code	Description	Recommended values based on the heat exchanger	
		Tube bundle	Plate
U050	User side frost protection: alarm threshold	-0.3 °C	-1.2 °C
U051	User side frost protection: differential	30 °C	30 °C
U052	User-side frost protection: delay time at 1K	90 s	60 s

Tab. 5.f

With pure water, the frost protection threshold must be set just below zero (from -0.8°C to -1.5°C) to account for the heat transfer temperature gradient across the metal between the refrigerant and the water. For tube bundle heat exchangers, values close to zero (above -0.5°C) should be considered, to guarantee better protection due to their specific mechanical construction.

5.3.2 Frost protection threshold with glide (R407C)

A correct frost protection threshold also needs to consider the minimum temperature reached inside the evaporator. When using refrigerants without glide or with minimum glide (e.g. R410A, R134a), the value coincides with the pressure-temperature conversion (dew) of the transducer fitted on the suction pipe, while for refrigerants with glide (e.g. R407C), the value to be used is lower than the pressure-temperature conversion (in the case of R407C it is 5-6°C). The following diagram clearly shows the difference between the two temperature values (T_{in} and T_{out}) at the evaporation pressure (P_{evap}) due to the "glide" effect of the refrigerant.

P-H Diagram - Zeotropic Blend

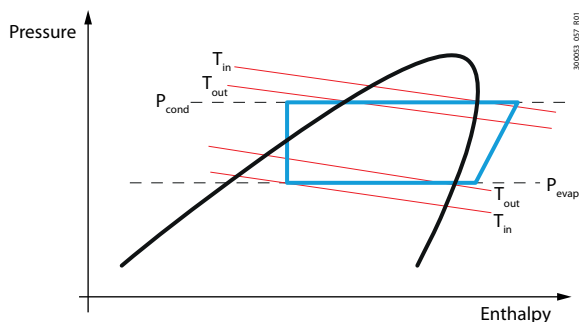

Key

T_{in} (P_{evap})	Evaporator refrigerant inlet temperature
T_{out} (P_{evap})	Saturated evaporation temperature "dew"
P_{cond}	Condensing pressure
P_{evap}	Evaporation pressure

Note: as a consequence of the above, the suggested frost protection set point with pure water and R407C refrigerant is 4-4.5°C.

Fig. 5.j

5.3.3 Frost protection alarm with water temperature

The frost protection alarm uses the water delivery probe (user) in cooling mode, while in heating mode, on water/water units, it uses the water temperature. When there is a frost alarm, the corresponding circuits are shut down. When the temperature is below the alarm threshold, the alarm is activated, and it is reset when it rises back above the threshold plus a differential.

User	Code	Description	Def	Min	Max	UOM
S	U050	User side frost protection: alarm threshold	-0.8	-99.9	999.9	°C
S	U051	User side frost protection: differential	30.0	0.0	999.9	K

5.3.4 Frost prevention

The frost protection threshold on the evaporation temperature is used as the minimum evaporation temperature threshold for frost prevention. Prevention is applied by limiting circuit capacity when the threshold is exceeded and activating on the frost protection heater, if configured. For details on configuring the frost protection heater, see the next paragraph, par 5.3.5

Notice: to ensure correct user-side frost protection, at least one probe - evaporation pressure/temperature or delivery water temperature - must be configured. For further details, see par 2.12.5 Disabling frost protection and/or free cooling when no probe is configured.

5.3.5 Frost protection management with two circuits

Frost protection management on Legacy models

The “Legacy” model for backward compatibility allows frost protection control only on the water temperature.

For units with a common evaporator (F003 = 0), frost protection control uses the common delivery temperature and the frost protection alarm shuts the unit down. If the common delivery temperature probe is not configured, frost protection control is disabled.

For units with two independent evaporators (F003 = 1), frost protection control is managed independently on each circuit. In this case, the frost protection alarm only stops the corresponding circuit. It can be normal for one circuit to stop due to a frost protection alarm while the other continues operating, when there are no additional alarm conditions.

Frost protection control uses the water outlet temperature probe on each evaporator.

If no outlet temperature probe is configured, frost protection control is disabled

Frost protection management on the standard model

The standard model does not manage independent evaporators (F003 = 0, not modifiable). Frost protection control can be selected to use the evaporation pressure/temperature or water temperature.

Frost protection control on evaporation pressure/temperature is managed independently on each circuit. The frost protection alarm only stops the corresponding circuit. Frost protection control uses the evaporation temperature (see par 5.3.1 for further details). If frost protection control is set on the water temperature, the frost protection alarm shuts the unit down.

If no frost protection control probe is configured, frost protection control is disabled

The following table illustrates frost protection management on a case-by-case basis for units with two circuits. For single-circuit units, management is practically the same, with only the difference that the frost protection alarm always shuts the unit down.

µChiller	Frost protection (U082)	Device	Unit status	Management
Standard	On water and/or on evaporation probe	Source User	OFF	Frost protection control is only performed on circuit 1, using the outlet temperature probe. When the frost protection threshold is reached, alarm signal A28 is activated. The heater is activated, where configured.
Standard	On water	User (CH) Source (HP WW)	ON	The standard µChiller does not manage two independent evaporators, each with its own outlet probe, but rather manages frost protection control using the common delivery temperature probe, which can only be configured on circuit 1. Frost protection control only uses this probe. The frost protection alarm shuts the unit down. The frost protection heater is activated if configured.
Standard	On evaporator probe	User (CH) Source (HP WW)	ON	Frost protection control is performed on both circuits independently, each with its own evaporation pressure/temperature probe. The frost protection alarm only stops the corresponding circuit. The heater in the circuit with the frost protection alarm is activated. If there are no additional alarm conditions, the other circuit continues operating normally.
Legacy	On water	User (CH) Source (HP WW)	OFF	Frost protection control is only performed on circuit 1. The common delivery temperature probe is used. The frost protection heater is activated on both circuits. The frost protection heater and auxiliary heater are activated if configured.
Legacy	On water	User (CH) Source (HP WW)	ON	1 - Evaporators with common water circuit (F003 = 0) Frost protection control uses the common delivery temperature probe. The frost protection heater and auxiliary heater are activated if configured. 2 - Independent evaporators (F003 = 1) Frost protection control is managed independently using the delivery temperature in each circuit. If there are no additional alarm conditions, the other circuit continues operating normally. The frost protection heater and auxiliary heater are activated if configured.

Tab. 5.g

Notice:

- The frost protection heater is always controlled based on its position and the unit operating mode, heating or cooling. See par. 5.6.7
- The second frost protection heater will only be linked to the frost protection control function on the second circuit and will never be used as the second frost protection stage.

5.3.6 Frost protection with the unit OFF

When the unit switched off, μ Chiller provides frost protection: the water is prevented from freezing by activating a pump and/or frost protection heater. When the water temperature in the heat exchangers reaches the frost protection set point, the selected device is activated. The probe used is the one located on the user heat exchanger outlet and source heat exchanger inlet. The following devices can be activated:

- heater;
- pump;
- heater and pump.

The frost protection alarm signal is shown even if the unit is off.

Considering that there is only one digital output per circuit for the heaters, the installation position of the frost protection heater needs to be selected using parameter U088, between:

- user
- source
- user and source (one digital output for both heaters)

5.3.7 Frost protection heater configuration

To correctly configure the frost protection heater, in addition to setting parameter U088, the digital output also needs to be set as "frost protection heater". Only one heater can be configured per circuit. For further details also see par. 6.6

User	Code	Description	Def	Min	Max	UOM
S	U053	Unit OFF: frost protection set point	4.0	-99.9	999.9	°C
S	U054	Unit OFF: frost protection differential	2.0	0.0	99.9	K
S	U075	Frost protection type - 0=Heater 1=Pump 2=Heater/pump	2	0	2	-
S	U088	Frost protection heater position - 0 = User 1 = Source 2 = User/Source	0	0	2	-

The frost protection heater is also activated in the event of an frost protection alarm when the unit is ON, after the unit and/or circuit is stopped.

5.4 Compressor rotation

If there is just one compressor, the temperature control request will be exactly the same as the request that the compressor needs to satisfy. On units with two compressors, μ Chiller manages rotation in order to balance compressor operating hours and starts, so as to best deliver the required capacity.

5.4.1 Type of rotation

μ Chiller starts and stops the compressors based on:

- FIFO rotation (First In First Out), meaning the first compressor to start will also be the first to stop;
- activation time: the first compressor to start will be the one with the lowest number of operating hours.

If the circuit is equipped with a variable-speed (BLDC) compressor, this will always be the first to start and the last to stop.

User	Code	Description	Def	Min	Max	UOM
M	C048	Compressor rotation type - 1=FIFO, 2=Time	1	1	2	-

5.4.2 Capacity distribution

μ Chiller manages the most suitable capacity distribution between the circuits so as to increase overall unit efficiency. The behaviour of capacity distribution varies based on:

- whether there are 1 or 2 circuits;
- the type of compressor(s) used: modulating (BLDC) or fixed speed;
- the ratio between compressor capacities.

To avoid simultaneous starts or stops of several compressors, there are two fixed minimum delays: one between starts (30 s) and the other (10 s) between stops.

Compressor capacity distribution in steps

Below is an example of capacity distribution with two circuits in the tandem configuration with two fixed-speed compressors (scroll), each with the same capacity, and FIFO rotation.

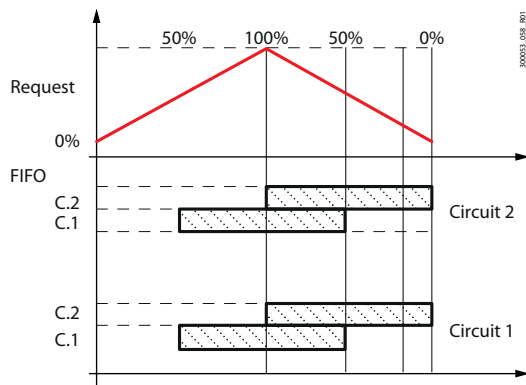
Key

Request	Capacity request (temperature control)
C.1	Compressor 1
C.2	Compressor 2

Fig. 5.k

Capacity distribution with BLDC compressors

If the circuit is equipped with a BLDC compressor, this will always be the first to start and the last to stop. Circuit operation is modulated so as to meet the capacity request, adjusting BLDC compressor speed and controlling the activation of ON-OFF compressors.

Note: the configuration envisaged requires the capacity of the ON/OFF compressor to be equal to 60% of the capacity of the BLDC compressor (at maximum speed).

5.4.3 Rotation due to alarm

In the event of a compressor alarm, the next compressor available will be switched on as a replacement if the temperature control request is sufficiently high as to warrant starting another compressor.

5.4.4 Force rotation (destabilisation)

Some compressor manufacturers specify that on units with multiple compressors, the compressors need to be rotated after a certain period of inactivity, even if control is stable.

The destabilisation function, which meets this requirement:

- can be enabled by parameter;
- avoids refrigerant migration during long periods of inactivity;
- can also be used to keep all the compressors at operating temperature.

User	Code	Description	Def	Min	Max	UOM
M	C020	Maximum circuit destabilisation time	240	5	999	min
M	C044	Enable destabilisation - 0/1=No/Yes	1	0	1	-

5.5 Compressor management

µChiller manages scroll compressors with direct starting or modulating BLDC compressors (scroll and rotary). A maximum of 4 scroll compressors are available in tandem configuration on two circuits; in the High Efficiency models, with BLDC compressors, the maximum is 1BLDC+1On-Off per circuit.

The flow chart below shows the process for calculating the request to the compressors:

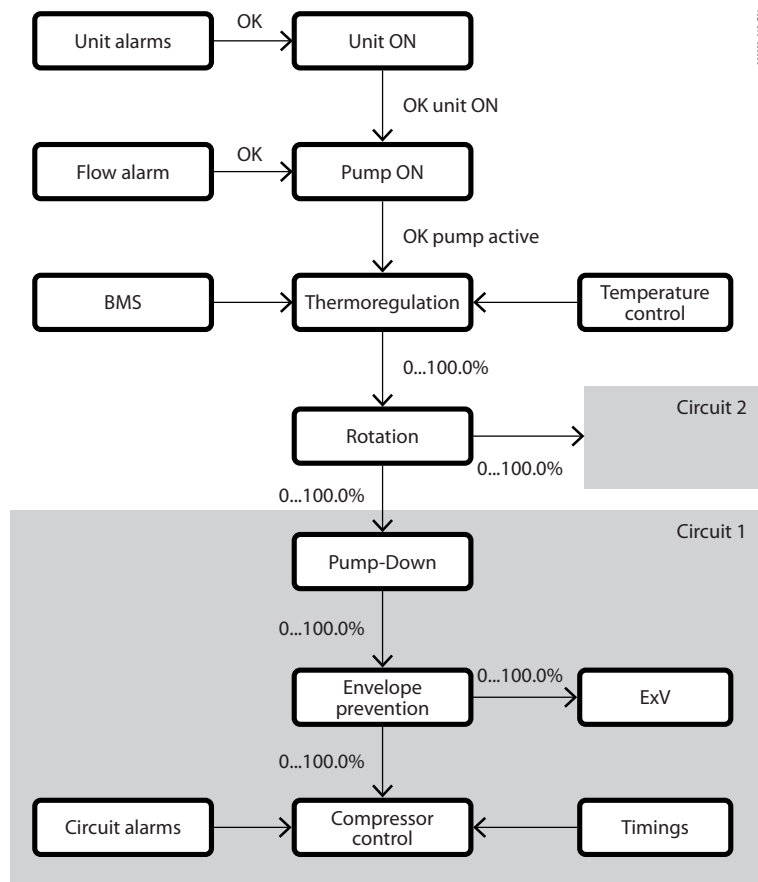

Note: for the sake of simplicity, the parameters are shown for just one compressor and one circuit, therefore all the compressors and circuits on the unit will have the same settings.

Fig. 5.1

5.5.1 Predefined BLDC compressors

The type of BLDC compressor can be chosen from the list of compressors available on KSA (ksa.carel.com), µChiller section.

When selecting a specific type of compressor, the following parameters are set based on the compressor manufacturer's technical specifications:

1. compressor motor:
 - all the characteristic electrical parameters of the compressor motor;
 - minimum and maximum frequency settings, acceleration and deceleration ramps.
2. compressor envelope:
 - all the characteristic points that define the shape of the compressor envelope;
 - maximum discharge temperature (compressor outlet).
3. compressor envelope management:
 - MOP and pressure difference (DeltaP), minimum ExV opening parameters;
 - working point control parameters;
 - prevention parameters.

5.5.2 Safety times

µChiller guarantees compliance with compressor safety times, such as:

- minimum on time;
- minimum off time after deactivation request from controller;
- minimum time between consecutive starts.

User	Code	Description	Def	Min	Max	UOM
M	C012	Min compressor on time	180	30	999	s
M	C013	Min compressor off time	60	30	999	s
M	C014	Min time between consecutive compressor starts	360	300	999	s

5.5.3 BLDC compressor start-up

µChiller manages the start-up of BLDC compressors in accordance with the manufacturer's specifications: on starting, the compressor is brought to start-up speed and kept at that speed, irrespective of the control request, for the entire minimum on time. At the end of this period, the speed is modulated by the controller, based on:

- request;
- position of the working point in relation to the compressor envelope (see par. "Prevention actions").

Note: if at start-up the differential pressure is greater than the maximum allowed start-up threshold, the compressor remains on call awaiting the pressure to drop below the threshold. If after 5 minutes the compressor has not yet started, a specific alarm will be activated (A43/A76). However, this alarm still allows the other compressors to start.

User	Code	Description	Def	Min	Max	UOM
M	P021	Max. deltaP at start-up	900.0	0.0	2000.0	kPa

5.5.4 BLDC oil recovery

When the refrigerant gas speed in the circuit is below the value required to entrain the oil, operation periodically needs to be set to a sufficient value to guarantee oil return to the compressor crankcase.

The function forces an increase in BLDC compressor capacity for a specific time, when the circuit has remained at low load (par. P007) for a minimum time (par. P008).

User	Code	Description	Def	Min	Max	UOM
M	P018	Enable oil recovery - 0/1=No/Yes	0	0	1	-
M	P007	Oil recovery: min speed for activation	35.0	0.0	999.9	rps
M	P008	Oil recovery: comp. operating time at low speed	15	0	999	min
M	P009	Oil recovery: force comp. speed time	3	0	999	min
M	P010	Oil recovery: force comp. speed value	50.0	0.0	999.9	rps

5.5.5 Tandem BLDC oil equalisation

A solenoid valve is activated to take the oil from the crankcase overflow on each compressor and put it back in circulation (for example, at the inlet to the common manifold). If the function is enabled, when the fixed speed compressor starts, the solenoid valve is activated for an initial time (par. P011), and then cyclically for a time (par. P012), with a pause that increases over time from the minimum value (par. P013) to the maximum value (par. P014) in the specified time (par. P015).

User	Code	Description	Def	Min	Max	UOM
M	P017	Enable oil recovery - 0/1=No/Yes	0	0	1	-
M	P011	Oil recovery: min speed for activation	30	0	999	s
M	P012	Oil recovery: comp. operating time at low speed	3	0	999	s
M	P013	Oil recovery: force comp. speed time	1	0	999	min
M	P014	Oil recovery: force comp. speed value	15	0	999	min
M	P015	Equalizzazione olio: tempo incremento elettrovalvola chiusa	20	0	999	min

5.5.6 Compressors with capacity control (Legacy model only)

For Legacy models, compressors can be capacity-controlled in the compressor plus valve configuration, on a maximum of two circuits. For compressors with capacity control, the FIFO or timed rotation logic will refer to the circuit and not to the compressor valves.

Example: if circuit 1 starts when power returns, compressor 1 starts at part capacity, then the valve is managed as the second step, so that the compressor works at the highest efficiency. If less capacity is needed, first the valve that manages compressor capacity will be deactivated and then the compressor itself. There is no rotation between compressor and valve. When capacity is needed again, the second circuit with compressor 2 will be activated and, subsequently, if required, the corresponding valve. On deactivation, the valve will be managed first, and only then the compressor.

User	Code	Description	Def	Min	Max	UOM
M	F027	Enable compressor capacity control 0/1=No/Yes	0	0	1	-

5.6 BLDC compressor protectors

To prevent the compressor from working outside the safety limits specified by the manufacturer, μ Chiller provides controls the operating limits (defined as the envelope) of BLDC compressors. In addition to the operating limits specified by the manufacturer, the maximum condensing temperature (par. P001) and minimum evaporation thresholds (par. P000) can be customised; these custom thresholds are considered only if they are more restrictive than the manufacturer's limits. On-Off compressors have no envelope data: the operating limits can be set using the parameters for the maximum high pressure threshold equivalent temperature (par. C017), frost protection alarm thresholds (par. U050 and S057) and MOP threshold (to control the maximum evaporation temperature, par. E020 and E022).

Utente	Cod.	Descrizione	Def	Min	Max	U.M.
S	P000	Min evaporation temp.: custom limit	-25.0	-99.9	999.9	°C/°F
S	P001	Max condensing temp.: custom limit	70.0	-99.9	999.9	°C/°F
M	C017	Max high pressure threshold (HP)	65.0	0.0	999.9	°C
M	C018	Min low pressure threshold (LP)	0.2	-99.9	99.9	bar
S	U050	User side frost protection: alarm threshold	-0.8	-99.9	999.9	°C
S	S057	Source frost protection: alarm threshold	-0.8	-999.9	999.9	K
M	E020	MOP in cooling: threshold	30.0	-60.0	200.0	°C
M	E022	MOP in heating: threshold	20.0	-60.0	200.0	°C

Di seguito la descrizione delle zone di lavoro di un involucro generico di un compressore BLDC:

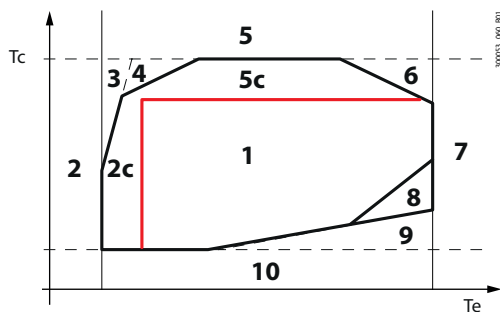

Fig. 5.m

Zone	Par.	Description
1		Zone inside the operating limits (the prevention function is still active to prevent operation outside of the limits)
2a		Maximum compression ratio 1
2b		Maximum compression ratio 2
3		Maximum condensing pressure
3c	P001	Custom maximum condensing pressure threshold
4		Maximum motor current
5		Maximum evaporation pressure
6		Minimum compression ratio
7		Minimum differential pressure
8		Minimum condensing pressure
9		Minimum evaporation pressure
9c	P000	Custom minimum evaporation pressure threshold
10		High discharge temperature (but working pressure inside the envelope)

Tab. 5.h

When the compressor working point is outside of the envelope, an alarm delay starts counting: if the working point remains outside of the envelope, when the delay expires, a specific alarm is activated that stops the compressor; if, on the other hand, the working point returns back inside the envelope limits, the alarm delay is reset.

The high condensing pressure limit is determined by the minimum between:

- the nominal compressor threshold;
- the threshold modifiable by Service (par. P001).

The high evaporation pressure limit is determined by the minimum between:

- the nominal compressor threshold;
- the set MOP threshold (par. E020: chiller and E022: heat pump);

The low evaporation pressure limit for the prevention action is determined by maximum between:

- the nominal compressor threshold;
- the threshold modifiable by Service (par. P000);
- the frost protection limit, depending on the mode (par. U050 in cooling and par. S057 in heating with water/water units).

In addition to the operating limits defined by the shape of the envelope, there is also (heat pump versions only) a "Maximum discharge temperature" limit (specified by the compressor manufacturer), at which the compressor is shut down.

5.7 BLDC comp. alarm prevention

The evaporation and condensation pressures determine a working point in a zone of the envelope, and depending on the zone, the controller applies corrective actions to maintain or return BLDC compressor operation within the limits.

5.7.1 Prevention actions for BLDC compressors

Below is the description of the working zones in a generic envelope for BLDC compressors:

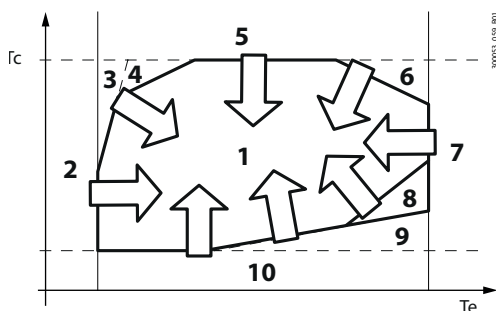

Fig. 5.n

Zone	Descrizione
1	Zone inside the operating limits
2	Prevention due to high compression ratio
3	Prevention due to high condensing pressure
4	Prevention due to high motor current
5	Prevention due to high evaporation pressure
6	Prevention due to low compression ratio
7	Prevention due to low differential pressure
8	Prevention due to low condensing pressure
9	Prevention due to low evaporation pressure

Tab. 5.i

To allow the compressor to work inside the envelope, specific prevention actions are adopted that adjust circuit capacity, the source fan set point and the opening of the ExV valve.

In particular, the actions involving circuit capacity are:

- decrease the rate at which the capacity request from the temperature controller increases/decreases when approaching the limit of the envelope;
- limit/increase circuit capacity.

The action on the ExV valve is applied by varying the MOP threshold (maximum evaporation temperature): the algorithm follows the set point, decreasing valve opening, and therefore reducing the mass flow of refrigerant, which in turn lowers the evaporation temperature. This action is applied with both BLDC compressors and fixed-speed compressors.

The actions involving the rate of capacity variation start when the working point is a set distance from the compressor operating limits. These actions are only possible with BLDC compressors.

In the event of fixed-speed compressors, the only actions possible on the circuit are to limit capacity via the number of the compressors on: this is implemented as soon as the working point exceeds the maximum condensing temperature (par. C017) or minimum evaporation temperature (par. U050/S057) or minimum evaporation threshold (par. C018) - or the minimum of the two.

Below are details of the various actions to prevent the operating limits from being exceeded; action 1 refers to the control action (before exiting the envelope); action 2 to the limiting action (working point already outside of the envelope).

Low evaporation pressure prevention (zone 9)

The low evaporation pressure limit for the prevention action is determined by maximum between:

- the nominal compressor threshold (BLDC only);
- the threshold set by the "Manufacturer": par. C018/P000 for On-Off/BLDC compressor;
- the frost protection limit, depending on the operating mode: par. U050 in cooling mode and S057 in heating mode with water/water units.

Device	Description
BLDC compressor	1. Decrease the rate of capacity increase. 2. Limit capacity
Tandem on-off compressors	1. - 2. Shutdown a compressor
ExV	-
Fan	-

High compression ratio prevention (zone 2)

A high compression ratio is a thermal limit of compressor operation: normally control is activated at the limit of the envelope, reducing capacity when the limit is exceeded; if a probe is fitted to measure discharge temperature (HP version only) and if the temperature approaches the limits, compressor capacity will be modulated so as to managed the critical condition. A specific algorithm initially slows down the increase in capacity, until stopping it completely when at the set point (5°C below the maximum limit); if the temperature increases further, the algorithm gradually and slowly reduces capacity, taking into account compressor thermal inertia.

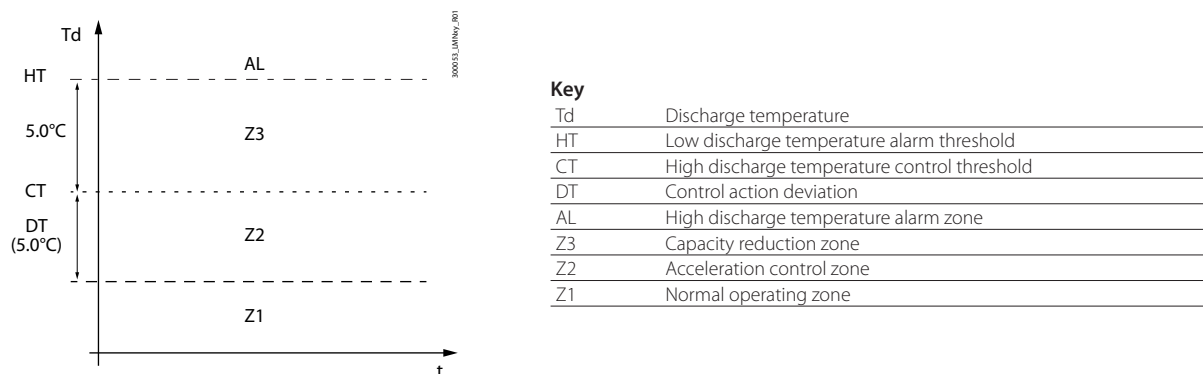

Fig. 5.0

Device	Description
BLDC compressor	1. Decrease the rate of capacity increase. 2. Limit capacity
Tandem on-off compressors	-
ExV valve	-
Fan	-

High condensing pressure prevention (zone 3)

Device	Description
BLDC compressor	1. Decrease the rate of capacity increase. 2. Limit capacity
Tandem on-off compressors	1. - 2. Shutdown a compressor
ExV valve	-
Fan	-

High motor current prevention (zone 4)

Device	Description
BLDC compressor	1. Decrease the rate of capacity increase. 2. Limit capacity
Tandem on-off compressors	1. - 2. Shutdown a compressor
ExV valve	MOP with specific algorithm
Fan	-

High evaporation pressure prevention (zone 5)

Device	Description
BLDC compressor	1. Decrease the rate of capacity reduction. 2.
Tandem on-off compressors	-
ExV valve	MOP
Fan	-

Low compression ratio prevention (zone 6)

Device	Description
BLDC compressor	1. Decrease the rate of capacity reduction. 2. Increase capacity
Tandem on-off compressors	-
ExV valve	Variable MOP
Fan	Increase condensing pressure set point/decrease evaporation pressure setpoint

Low differential pressure prevention (zone 7)

Device	Description
BLDC compressor	1. Decrease the rate of capacity reduction. 2. Increase capacity
Tandem on-off compressors	-
ExV valve	Variable MOP
Fan	Increase condensing pressure set point/decrease evaporation pressure setpoint

Low condensing pressure prevention (zone 8)

Device	Description
BLDC compressor	1. Decrease the rate of capacity reduction. 2. Increase capacity
Tandem on-off compressors	-
ExV valve	-
Fan	-

5.8 Compressor alarms

If abnormal conditions occur and the prevention actions are not effective, the compressor will be shut down so as to avoid damage to the compressor itself or other unit components, i.e. the control algorithm stops the compressors and closes the expansion valve.

Compressor shutdown

The compressors will be available again after the:

- minimum compressor off time (par. C013);
- minimum time between consecutive compressor starts (par. C014).

User	Code	Description	Def	Min	Max	UOM
M	C013	Min compressor off time	60	30	999	s
M	C014	Min time between consecutive compressor starts	360	300	999	s

Compressor delay at start-up/in operatio

Compressor start-up is a critical phase. μ Chiller thus manages certain alarms differently, in order to switch smoothly from start-up to normal, steady operation. These alarms are:

- low differential pressure;
- out of envelope alarm.

There are thus two delays for these alarms:

- delay at start-up;
- delay in operation.

The alarm condition is ignored when the compressor is off and during the start-up phase. When the unit reaches steady operation, the condition causes the corresponding alarm once the delay has elapsed.

Behaviour will thus be as follows

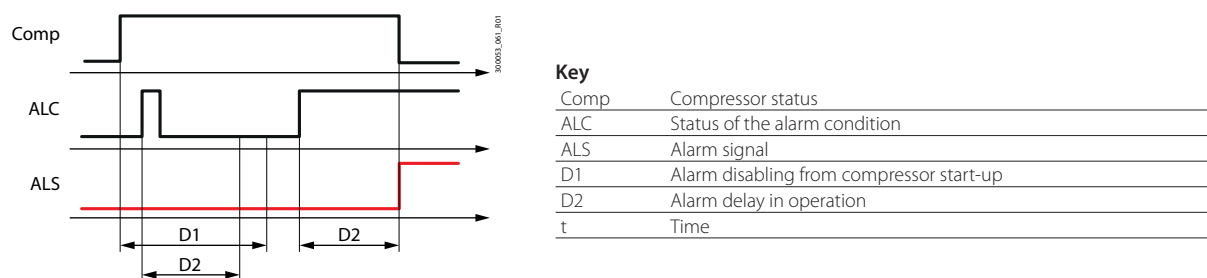

Fig. 5.p

5.9 Power+ Speed drive

When the unit is fitted with a BLDC compressor, this is controlled by the Power+ speed drive, connected to the FBus serial port on μ Chiller via the Modbus circuit 1 protocol with a baud rate of 19200 bps. Use a specific cable for RS485 (AWG20-22 with 1½ twisted pair plus shield). See the Power+ instruction manual +0300048EN.

5.10 Expansion valve driver

The driver to manage the electronic expansion valve is a fundamental device for the μ Chiller controller. This is used to safely manage the compressor and thus the circuit, constantly controlling the discharge temperature and the position of the working point inside the compressor envelope. The solution provided manages unipolar valves up to a certain cooling capacity (Carel E3V - cooling capacity up to 90- 100 kW) with the built-in driver (DIN model only) and bipolar valves with higher capacities, using the external EVD Evolution driver. This must be connected to the FBus serial port on μ Chiller via the Modbus circuit 1 protocol with a baud rate of 19200 bps. Use a specific cable for RS485 (AWG20- 22 with 1½ twisted pair plus shield). See the chapter "Installation".

Note:

- EVD Evolution is only used as an expansion valve positioner;
- if the ExV electronic expansion valve is used, the suction temperature probe is connected to input S3 (panel model) or S7 (DIN rail model). See the functional diagrams. For the installation guidelines, see document +040010025, available at www.carel.com.

5.11 Control of the expansion valve

The control logic manages various functions:

- communication with the EVD Evolution driver, if used (read/write parameters via FBus serial port);
- control of suction superheat (SSH);
- low superheat control and alarm (Low SH);
- minimum evaporation temperature control and alarm (LOP);
- maximum evaporation temperature control and alarm (MOP);
- control of cooling capacity, so as to position the valve correctly in the transient stages according to circuit control status;
- control algorithm that calculates the valve opening steps;
- valve opening value sent to the valve driver.

If the EVD Evolution driver is offline, all the compressors are stopped immediately.

Dedicated electronic expansion valve parameters

Certain parameters relating to the electronic expansion valve vary according to the operating mode:

- chiller;
- heat pump. These are:
- superheat parameters (set point and PID);
- alarm thresholds and integral actions for protection functions: LOP, MOP and Low SH

5.12 Source pump

μ Chiller manages one source-side pump (water/water units only). In the same way as for the user pumps, the source pump is activated when the unit is switched on, and a shutdown delay after the last compressor stops can be set.

The source pump can be activated:

- when the unit is switched on, and after a set delay for switching off after the unit has been switched off;
- when the first compressor starts, and after a set delay for switching off after the last compressor stops;
- via temperature control. Below is a table summarising the probes used for controlling the pump in each configuration:

Circuit	Probes used for control	
	Chiller	Heat pump
1	Condensing press./temp. circuit 1	Evaporation press./temp. circuit 1
2	Condensing press./temp. circuit 2	Evaporation press./temp. circuit 2

Tab. 5.j

μ Chiller manages:

- frost protection with the unit off: the pump is started so as to activate fluid circulation (when the unit is on the function is disabled).
- pump anti-blocking: if the pump is off for more than a week, it is activated for 3 seconds

User	Code	Description	Def	Min	Max	UOM
S	S072	Source pump activation 0=Always on 1= On with compressor on 2= Control on condensing press./temp.	0	0	2	-
S	S028	Source pump in cooling: set point	30.0	-999.9	999.9	°C
S	S029	Source pump in heating: set point	10.0	0.0	99.9	°C
S	S034	Source pump: differential in cooling	15.0	0.0	99.9	K
S	S035	Source pump: differential in heating	5.0	0.0	99.9	K

5.13 Source fans

On units with two circuits, μ Chiller manages the source (condenser) either separately (independent air circuits) or with one common air circuit, by setting a parameter: when there is a common air circuit, fan 1 works based on the higher request between circuit 1 and 2.

User	Code	Description	Def	Min	Max	UOM
S	S064	Type of source air circuit - 0 = Independent 1 = Common	0	0	1	-

Below is a table summarising the probes used for controlling the fans in each configuration:

Circuit	Probes used for control	
	Chiller	Heat pump
1	Condensing press./temp. circuit 1	Evaporation press./temp. circuit 1
2	Condensing press./temp. circuit 2	Evaporation press./temp. circuit 2

Tab. 5.a

The control mode changes based on the operating mode (chiller or heat pump).

5.13.1 Modulating/On-Off fans

On the μ Chiller panel version, analogue output Y1 is the only output available: consequently to control an on-off fan, a CONVO-NOFF module (Carel) is needed to convert the 0-10V analogue output into a relay control. On the versions for DIN rail mounting, relay NO6 is available and can be configured as a fan output. On-Off fans then need to be configured.

User	Code	Description	Def	Min	Max	UOM
M	Hc12	NO6 configuration - 0=Frost protection 1=Source fan/pump	0	0	1	-
S	S065	Type of source fan 0/1=Modulating/ON-OFF	0	0	1	-
S	S028	Source fan in cooling: set point	30.0	-999.9	999.9	°C
S	S029	Source fan in heating: set point	10.0	0.0	99.9	°C
S	S031	Source fan in cooling: set point at start-up	45.0	0.0	999.9	°C
S	S032	Source fan: delay at start-up in cooling	240	0	999	s
S	S034	Source fan: differential in cooling	15.0	0.0	99.9	K
S	S035	Source fan: differential in heating	5.0	0.0	99.9	K
S	S036	Modulating source fan: min speed value	20.0	0.0	100.0	%
S	S037	Modulating source fan: max speed value	80.0	0.0	100.0	%

Tab. 5.b

The following diagram shows the two control modes (modulating or on-off) in chiller operation (cooling):

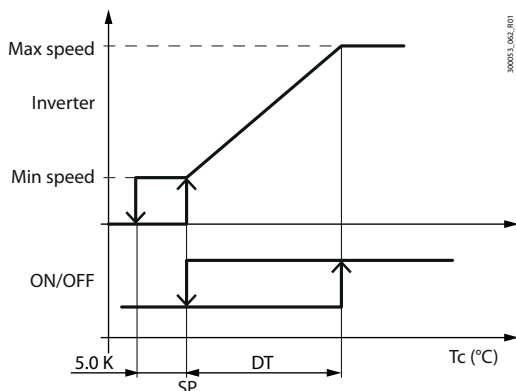

Fig. 5.q

Key

Max speed	Modulating source fan: max speed value
Min speed	Modulating source fan: min speed value
SP	Control set point
DT	Control differential
Tc	Condensing temperature

5.13.2 Control in chiller mode

Fan control may be modulating or ON-OFF and is based on the saturated temperature value, equivalent to the condensing pressure, limited by Tc max.

User	Code	Description	Def	Min	Max	UOM
S	C017	Max high pressure threshold (HP)	65.0	0.0	999.9	°C
S	S028	Source fan in cooling: set point	30.0	-999.9	999.9	°C
S	S034	Source fan: differential in cooling	15.0	0.0	99.9	K
S	S036	Modulating source fan: min speed value	20.0	0.0	100.0	%
S	S037	Modulating source fan: max speed value	80.0	0.0	100.0	%

The control diagram is shown below:

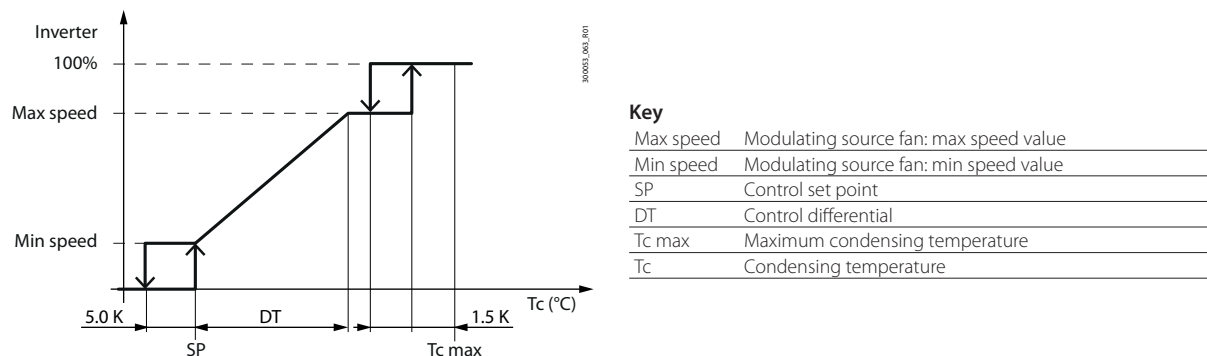

Fig. 5.r

In the graph, some offsets are expressed with a numerical value, indicating that they are not modifiable but rather are fixed parameters. The current calculated set point value is displayed on the dashboard.

Set point control

In chiller mode, a specific condensing temperature set point for starting the compressor can be set to a value that is higher than the nominal set point, so that the compressor can reach steady operation more quickly. The transition to the nominal set point is made gradually over a time equal to the delay at start-up.

User	Code	Description	Def	Min	Max	UOM
S	S031	Source fan in cooling: set point at start-up	45.0	0.0	999.9	°C
S	S032	Source fan: delay at start-up in cooling	240	0	999	s

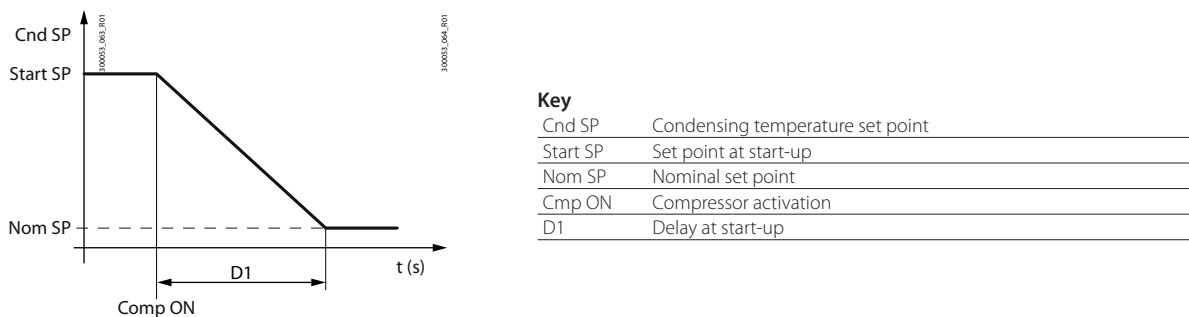

Fig. 5.s

5.13.3 Control in heat pump mode

Fan control may be modulating or ON-OFF and is based on the saturated temperature value, equivalent to the evaporation pressure.

User	Code	Description	Def	Min	Max	UOM
S	C017	Max high pressure threshold (HP)	65.0	0.0	999.9	°C
S	S029	Source fan in heating: set point	10.0	0.0	99.9	°C
S	S035	Source fan: differential in heating	5.0	0.0	99.9	K
S	S036	Modulating source fan: min speed value	20.0	0.0	100.0	%
S	S037	Modulating source fan: max speed value	80.0	0.0	100.0	%

The control diagram is shown below:

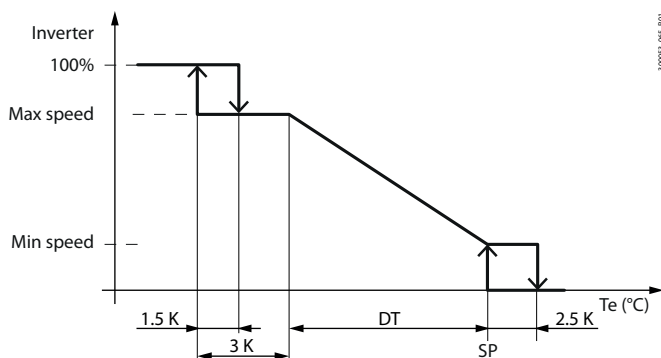

key

Max speed	Modulating source fan: max speed value
Min speed	Modulating source fan: min speed value
SP	Control set point
DT	Control differential
Tc max	Maximum condensing temp.
Te	Evaporation temperature

Fig. 5.t

In the graph, some offsets are expressed with a numerical value, indicating that they are not modifiable on the display but rather are fixed parameters. The current calculated set point value is displayed on the dashboard.

5.13.4 "Low noise" function

This function reduces the noise emitted by modulating fans by increasing the set point at night.

User	Code	Description	Def	Min	Max	UOM
S	S020	Enable noise reduction 0/1=No/Yes	0	0	1	-
S	S021	Noise reduction time band: start hours	22	0	23	h
S	S022	Noise reduction time band: start minutes	30	0	59	min
S	S023	Noise reduction time band: end hours	8	0	23	h
S	S024	Noise reduction time band: end minutes	30	0	59	min
S	S025	Source fan: noise reduction set point	45.0	0.0	999.9	°C

5.13.5 Fan anti-blocking function

For systems intended to operate in cold climates, µChiller modulates fan speed so as to prevent the unit from shutting down due to frost formation. The function is activated when the outdoor temperature falls below a threshold, and, instead of turning off the fans, keeps them on at a minimum speed. If the outside temperature is reached when the fans are off, these are activated at start-up speed for a certain time, and then switch to the minimum speed.

User	Code	Description	Def	Min	Max	UOM
S	S016	Source fan: cold climate temperature threshold	-0.5	-999.9	999.9	°C
S	S017	Source fan: min cold climate speed	10.0	0.0	100.0	%
S	S018	Source fan: cold climate speed at start-up	50.0	0.0	100.0	%
S	S019	Source fan: cold climate speed at start-up time	5	0	300	s

5.14 Free cooling

The free cooling (FC) function can be enabled only on chiller units. The type of free cooling is configured by parameter, and may be:

- air free cooling, on air/water units equipped with air- water heat exchanger coils upstream of the condenser coils and with modulating fan control;
- remote air free cooling (see the specific paragraph);
- water free cooling, on water/water units with mixing of the source water or via water- water heat exchanger upstream of the evaporator and a 3-way modulating valve on the free cooling circuit.

User	Code	Description	Def	Min	Max	UOM
S	U068	Free cooling: enable 0/1=no/yes	0	0	1	-
S	U069	Free cooling: activation differential	3.0	0.0	99.9	K
S	U070	Free cooling: hysteresis	1.5	0.0	99.9	K
S	U071	Design free cooling delta T	8.0	0.0	99.9	K
S	U072	Water free cooling: valve closing threshold	5.0	-999.9	999.9°C	°C
S	U073	Water free cooling: valve closing differential	3.0	0.0	99.9	K
M	U074	Free cooling type: 0=Air 1=Remote coil 2=Water	0	0	2	-

Free cooling is enabled when the outside source temperature is sufficiently lower than the temperature of the water entering the unit, as shown in the following figure:

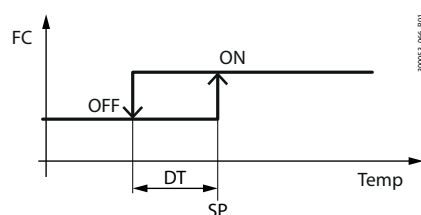

Key	
FC	Free cooling
DT	Hysteresis
SP	Activation differential
Temp	User return temperature - outside source temp.

Fig. 5.u

On air/water units, the fans are controlled based on the condensing temperature as long as the circuit's compressor is on; as soon as the compressor stops, the free cooling fan is controlled so as to maintain the desired water temperature set point.

5.15 Types of free cooling

5.15.1 Condensing unit with common air circuit

Free cooling is enabled based on the comparison between the user return water temperature and the outside air temperature; this directly controls switching of the three-way valve, which allows the water returning from the user terminals to flow through the free cooling coil before entering the evaporator. Free cooling capacity is controlled by modulating the fan speed (with the compressors off); in combined operation (free cooling + mechanical cooling), fan speed is controlled so as to correctly manage the condensing stage.

Inputs used:

To enable free cooling:

- User return temperature;
- Outside air temperature;

To manage capacity in free cooling mode:

- (according to the control probe used) Return/delivery water temp.

Outputs used:

- 0-10 V to manage the common fan between free cooling and condenser;
- Free cooling valve On-Off control.

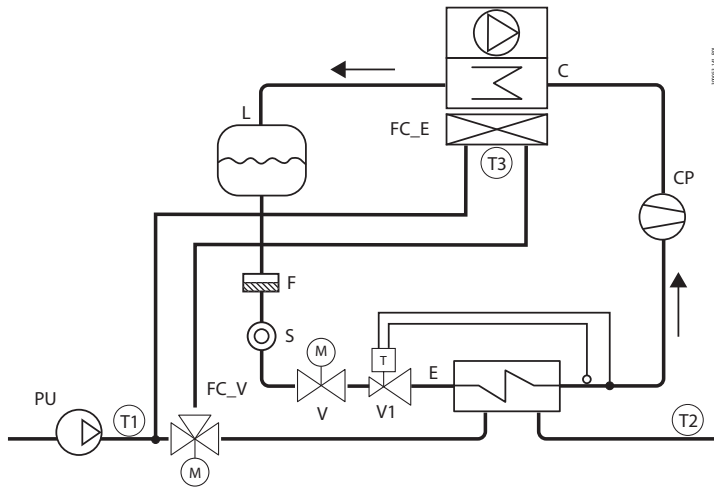

Ref.	Description
FC_E	Free cooling heat exchanger
C	Condenser
E	Evaporator
F	Filter-drier
L	Liquid receiver
CP	Compressor
S	Liquid sightglass
FC_V	Free cooling valve
PU	User pump
T1	User return probe
T2	User delivery probe
T3	Outside temperature probe
V1	Thermostatic expansion valve
V	Solenoid valve

Fig. 5.v

5.15.2 Air-cooled condensing unit with separate air circuit

Free cooling is enabled based on the comparison between the user return water temperature and the outside air temperature; this directly controls switching of the three-way valve, which allows the water returning from the user terminals to flow through the free cooling coil before entering the evaporator. Free cooling capacity is controlled by modulating the specific fan speed; in combined operation (free cooling + mechanical cooling), free cooling fan speed is always 100%.

Inputs used:

To enable free cooling:

- User return temperature;
- Outside air temperature;

To manage capacity in free cooling mode:

- (according to the control probe used) Return/delivery water temp.

Outputs used:

- 0-10 V to manage the condenser fan (Y1: Circuit 1 and Circuit 2)
- 0-10 V to manage the free cooling fan (Y2: Circuit 1);
- Free cooling valve On-Off control.

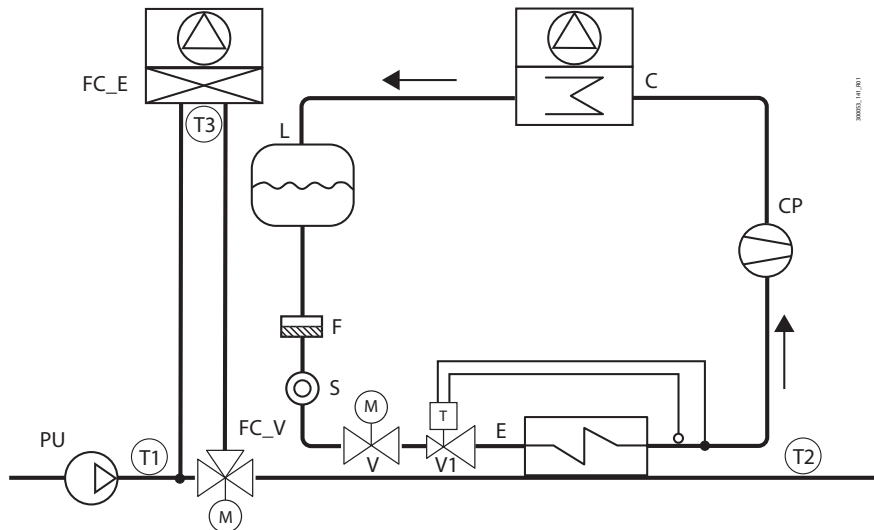

Fig. 5.w

Ref.	Description
FC_E	Free cooling heat exchanger
C	Condenser
E	Evaporator
F	Filter-drier
L	Liquid receiver
CP	Compressor
S	Liquid sightglass

Ref.	Description
FC_V	Free cooling valve
PU	User pump
T1	User return probe
T2	User delivery probe
T3	Outside temperature probe
V1	Thermostatic expansion valve
V	Solenoid valve

5.15.3 Water-cooled condensing unit

Free cooling is enabled based on the comparison between the user return water temperature and the source water temperature (Temp. IN source); this controls modulation of the three-way valve that mixes the source water with the water returning from the user terminals through the free cooling coil before entering the evaporator.

Free cooling capacity is controlled by modulating the three-way free cooling valve; in combined operation (free cooling + mechanical cooling), the three-way free cooling valve is always open at 100%.

Inputs used:

To enable free cooling:

- User return temperature;
- Source inlet temperature;

To manage capacity in free cooling mode:

- (according to the control probe used) Return/delivery water temp.

Outputs used:

- 0-10 V to manage the condenser fan
- 0-10 V to manage the free cooling valve.

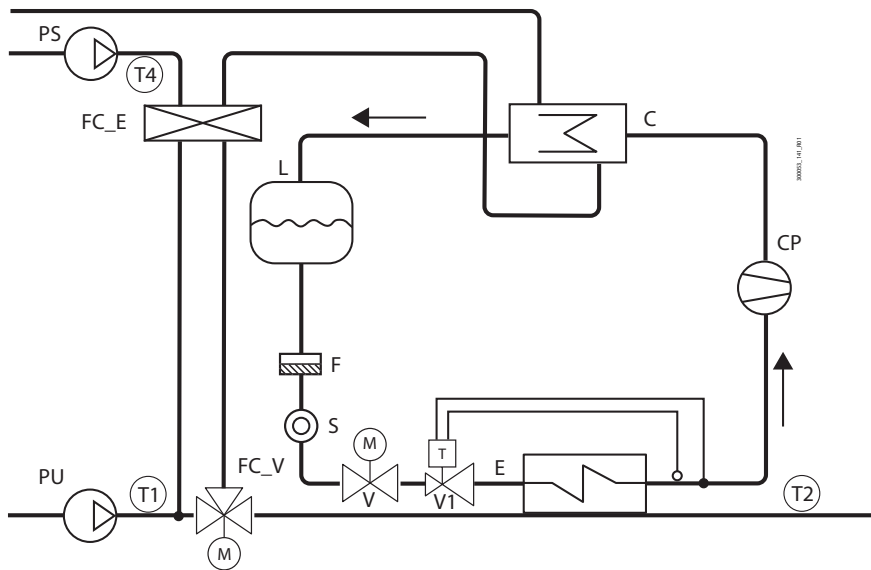

Fig. 5.x

Ref.	Description
FC_E	Free cooling heat exchanger
C	Condenser
E	Evaporator
F	Filter-drier
L	Liquid receiver
CP	Compressor
FC_V	Free cooling valve
S	Liquid sightglass

Ref.	Description
V	Solenoid valve
FC_V	Free cooling valve
PU	User pump
PS	Source pump
T1	User return probe
T2	User delivery probe
T4	Source return probe
V1	Thermostatic expansion valve

5.16 Free cooling

5.16.1 Dynamic control gain

This special function manages the balancing of capacity between the free cooling coil and the evaporator: this optimises control stability and fluidity.

User	Code	Description	Def	Min	Max	UOM
S	U070	Free cooling: hysteresis	1.5	0.0	99.9	K
S	U069	Free cooling: activation differential	3.0	0.0	99.9	K
S	U071	Design free cooling delta T	8.0	0.0	99.9	K

Tab. 5.k

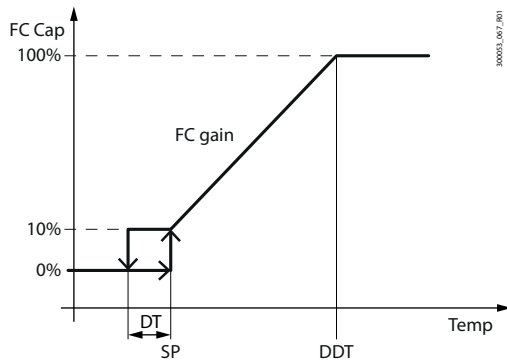

Fig. 5.y

Key

FC Cap	Free cooling capacity
DT	Hysteresis
SP	Activation differential
DDT	Design free cooling delta T
Temp	User return temp. - source temp.

The diagram shows the ideal behaviour of free cooling control (FC) in relation to its capacity; "Design free cooling delta T" is the temperature difference (water inlet - source) needed to cover the rated unit capacity using the free cooling coil only.

The value obtained - "FC gain" - is used to adapt the control ramp to the various cooling sources, as shown in the figure.

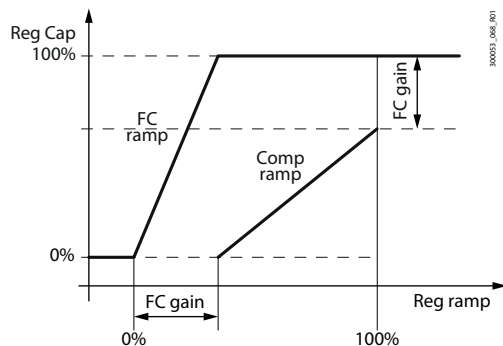

Fig. 5.z

Key

Reg Cap	Control capacity
FC ramp	Free cooling control ramp
FC gain	Dynamic gain of free cooling control
Comp ramp	Compressor control ramp
Reg ramp	Control ramp

The result is a perfect balance between the cooling capacities of the free cooling coil and the evaporator, in order to maintain the same proportionality in all load conditions. In other words, the same percentage of capacity is obtained for the same temperature variation in any load condition.

5.16.2 Effectiveness control

µChiller uses this function to start the compressors when the free cooling coil alone cannot bring the water to the set point, despite the fact that the source conditions theoretically allow for free cooling operation only. When this occurs, there may be a malfunction on the devices activated during free cooling; the compressors thus need to be started and free cooling disabled in order to ensure unit operation.

This situation is signalled by the "Free cooling warning".

5.16.3 Valve anti-block management

To avoid mechanical blocking of the valve, when a position (closed or open) is kept for more than a week, the valve is moved for 30 seconds to the opposite position.

5.17 Defrost

During heat pump operation on air/water units, the outdoor coil works as an evaporator. If the outside temperature is low, frost may form on the coil, resulting in reduced unit efficiency. To free the coil from frost and restore maximum efficiency, μ Chiller activates the defrost function. Activation depends on the value read by the reference probe (pressure transducer, low pressure side -> evaporation temperature in the graph), on the activation threshold being exceeded, and a possible delay.

User	Code	Description	Def	Min	Max	UOM
S	S039	Defrost: start temperature	-1.0	-99.9	99.0	°C
S	S040	Defrost: reset start defrost delay threshold	1.0	S039	99.9	°C
S	S041	Defrost: delay at start-up	30	0	999	min
S	S042	Defrost: end temperature	52.0	-999.9	999.9	°C
S	S046	Defrost: min duration	1	0	99	min
S	S047	Defrost: max duration	5	0	99	min

Example of defrost activation:

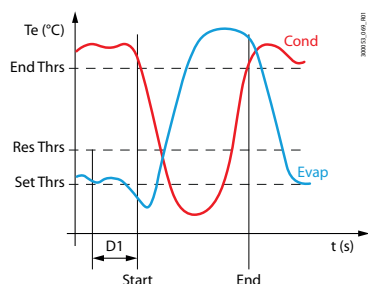

Key

T	Temperature
End Thrs	End defrost temperature
Res Thrs	Reset start defrost delay threshold
Set Thrs	Start defrost temperature
D1	Defrost start delay
Start	Start defrost
End	End defrost
T_Conc	Condensing temperature
T_Evap	Evaporation temperature

Fig. 5.aa

If the defrost temperature does not exceed the reset threshold during the defrost start delay, then the defrost starts. It ends when the reference probe (pressure transducer, high pressure side -> condensing temperature in the graph) exceeds the end defrost temperature or the maximum defrost duration has elapsed.

Note: for optimal defrost management, it is recommended to set the start defrost temperature to the evaporation temperature value at which ice starts forming on the coil (-1.0°C / -1.5°C); the defrost start delay expresses the time needed to accumulate a layer of ice that requires defrosting (30- 60 minutes). Also see the paragraph "Sliding defrost".

5.17.1 Defrost procedure

Notes: in the following description:

- "case with compressor ON" indicates that the phase is only featured if defrost is set with the compressor On;
- "case with compressor off" indicates that the phase is only featured if defrost is set with the compressor Off;

End defrost can be managed in two ways:

- with the compressor off: the thermal inertia of the condenser is used to end the defrost;
- with the compressor on: to make the defrost as fast as possible.

User	Code	Description	Def	Min	Max	UOM
M	S055	Compressor after defrost 0/1=On/Off	0	0	1	-

Compressor off at end defrost

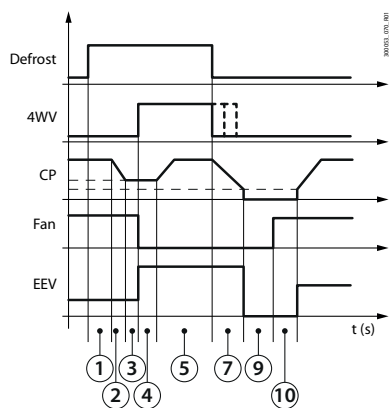

Fig. 5.ab

Compressor on for the entire defrost

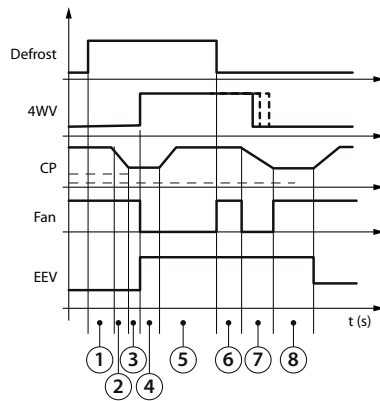

Fig. 5.ac

Key

Defrost	Defrost request
4WV	Cycle reversal (4-way valve)
CP	Compressor capacity
Fan	Enable fans
EEV	Electronic expansion valve

The control phases are described below.

Synchronisation (1)

Once the defrost start condition is true, there is a fixed delay of 10 s to check whether the other circuit requires defrosting, so as to carry out a simultaneous defrost if needed.

User	Code	Description	Def	Min	Max	UOM
S	S053	Defrost synchronisation: 0=Independent 1=Separate 2=Simultaneous	40.0	0.0	999.9	rps

Decrease capacity to start defrosting (2)

Capacity at start defrost can be managed in two ways:

- stopping the compressors
- compressors running at minimum power. For circuits with on-off compressors, a single compressor is kept on, while the compressor is kept at minimum capacity for circuits with BLDC compressor.

User	Code	Description	Def	Min	Max	UOM
M	S073	Compressor status at start defrost 0/1=On/Off	0	0	1	-
S	S052	BLDC compressor speed for cycle reversing in defrost	40.0	0.0	999.9	rps

Waiting time before reversing the cycle (3)

The 4-way valve is positioned in chiller mode to run the defrost, the fans are stopped and the compressor remains at the cycle-reversal speed for 5 seconds. Normally during this phase the electronic expansion valve tends to close, due to low superheat. As a result it is forced to the maximum opening so as to guarantee a constant flow of refrigerant and maximum defrost capacity.

User	Code	Description	Def	Min	Max	UOM
S	S044	Operation time at min capacity before cycle reversing	20	0	999	s

Cycle reversal and waiting time after reversal (4)

La valvola 4 vie si posiziona in modalità chiller per eseguire lo sbrinamento, i ventilatori si spengono e il compressore rimane alla velocità di inversione di ciclo per 5 secondi. Normalmente durante questa fase la valvola di espansione elettronica tende a chiudersi per basso surriscaldamento. Per questo essa è forzata alla massima apertura per garantire il flusso costante di refrigerante e la potenza massima di sbrinamento.

Defrosting (5)

The actual defrosting procedure starts: the compressor delivers full capacity so as to defrost the outdoor coil. In this phase, the BLDC compressor goes to the speed set by the corresponding parameter, the electronic expansion valve remains at the maximum opening and the fans remain off. The minimum/maximum defrost time and minimum time between two consecutive defrosts start counting in this phase.

User	Code	Description	Def	Min	Max	UOM
S	S046	Defrost: min duration	1	0	99	min
S	S047	Defrost: max duration	5	0	99	min
S	S050	Minimum delay between consecutive defrosts	20	0	999	min
S	S051	BLDC compressor speed in defrost	80.0	0.0	999.9	rps

The minimum defrost time protects compressors and circuit components from transients with high dynamics that are too close together. The maximum defrost time is a safety feature that avoids any abnormal conditions (end defrost threshold not reached - e.g. due to strong winds) that would stop the production of hot water required by the user terminals. The minimum time between consecutive defrosts is needed to prevent the unit from defrosting too frequently and thus only partly meeting demand. The actual defrosting procedure therefore ends after a maximum time or when the set condensing temperature is reached. If the compressor stops during this phase, the counters are reset.

Dripping (case with compressor on) (6)

In this phase, the compressor remains on at the defrost speed, the electronic valve is opened to the maximum and the fans are started at maximum speed, and remain at this speed for the entire dripping phase. The duration of the dripping phase can be set.

User	Code	Description	Def	Min	Max	UOM
S	S048	Dripping: duration	90	0	999	s

Decreased compressor capacity to end defrost (7)

Circuit capacity is reduced to the minimum and the cycle is reversed. In this phase, the fans are stopped (they are only activated if necessary for high pressure prevention) and the cycle reversing valve is moved to the heat pump position, controlled based on the difference between condensation and evaporation pressure: as soon as this pressure difference falls below the minimum differential for valve activation + 1 bar, the cycle is reversed (return to heat pump mode). If the reversing threshold is not reached, the cycle is reversed after a fixed time (60 s). The electronic expansion valve is opened to the maximum position.

User	Code	Description	Def	Min	Max	UOM
M	S054	4-way valve: pressure differential for reversing	3.0	0.0	999.9	bar

Waiting after cycle reversal (case with comp. ON) (8)

After reversing the cycle, there is a waiting time to ensure the correct flow of refrigerant; in this phase too, the ExV remains in the 100% open position.

User	Code	Description	Def	Min	Max	UOM
S	S045	Operation time at min capacity after cycle reversing	30	0	999	s

Dripping (case with comp. OFF) (9)

In this phase, the compressors, the electronic expansion valve and the fans are stopped, waiting for the coil to complete defrosting due to thermal inertia and stop dripping. The duration of the dripping phase can be set.

User	Code	Description	Def	Min	Max	UOM
S	S048	Dripping: duration - 0=Dripping not performed	90	0	999	s

Post-dripping phase (case with comp. OFF) (10)

During this phase, the fans are started at 100% speed to completely expel any water still on the coil. The duration of the post-dripping phase can be set. At the end of the post-dripping phase, the circuit is reactivated in normal heat pump operation.

User	Code	Description	Def	Min	Max	UOM
S	S049	Post-dripping: duration - 0=Post-dripping not performed	30	0	999	s

Quick start phase (case with comp. OFF) (11)

The compressor restarts based on the control request and the unit returns to normal operation. The start-up time is reduced so as to quickly bring compressor speed in line with the request.

User	Code	Description	Def	Min	Max	UOM
S	S056	BLDC smart start: duration (*)	20	0	999	s

(*) Shortened compressor start-up after defrost

This action assumes that the compressor has been off for a very short time, and therefore does not require complete preheating as is the case during normal start-up.

During the defrost phase (when the unit is in chiller mode), the fans are started if the condensing pressure exceeds the high condensing pressure alarm threshold - 5K.

User	Code	Description	Def	Min	Max	UOM
M	C017	Max high pressure threshold (HP)	65.0	0.0	999.9	°C

5.17.2 Defrost with fans

When the outside temperature allows (outside temperature > 6- 7°C), the fans alone can be used to defrost the coil, without operating the compressors, so as to improve system energy efficiency. When the outside temperature is greater than or equal to the value of S069, the function is activated: in this condition, the waiting time S041 before the defrost request is halved (to facilitate defrosting with fans only).

Note: if parameter S069 is set to 0.0°C (32°F), the function is disabled.

User	Code	Description	Def	Min	Max	UOM
S	S069	Defrost with fans: outside temperature threshold 0.0=Function disabled	0.0	0.0	99.9	°C

The defrost phases are as follows.

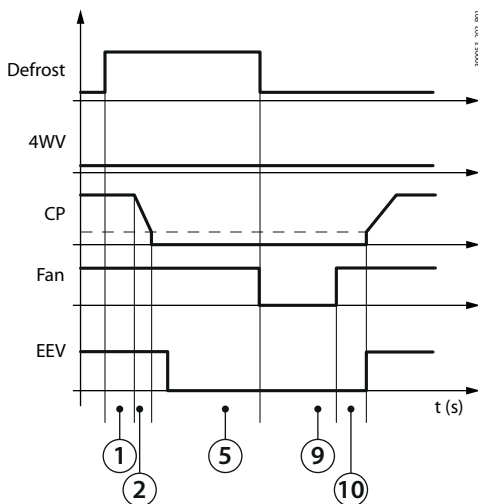

Fig. 5.ad

Synchronisation (1):
See the previous defrosts.

Compressor stopped to start defrosting (2)

The circuit with the BLDC compressor decreases its capacity to the minimum set value, and then switches off; on-off compressors are all switched off.

Defrosting (5)

The actual defrosting phase starts: the fans are started at 100% speed to heat the coil and melt the ice that has formed on the fins. Defrosting ends, once the minimum time has elapsed, when the evaporation temperature reaches 2°C, or after the maximum time. The minimum/maximum defrost time and minimum time between two consecutive defrosts start counting in this phase.

Dripping (9)

The fans are stopped, waiting for the coil to complete defrosting due to thermal inertia and stop dripping. The dripping time can be set.

Post-dripping (10)

The fans are started at 100% speed to completely expel any water still on the coil. The post-dripping time can be set. At the end of the post-dripping phase, the circuit is reactivated in normal heat pump operation.

5.17.3 Sliding defrost

As the water vapour content in the air decreases as the outside temperature decreases, the time needed for a layer of ice to form that requires defrosting increases proportionally as the outside temperature decreases. Consequently, a function has been added, enabled when the outside air probe is available, which extends the defrost delay time, as shown in the following figure.

Note: the outside probe can be connected to inputs S3/S6 (setting: external temperature)

User	Code	Description	Def	Min	Max	UOM
M	Hc00	S3 configuration 0=Not used 1=External temp. 2=Discharge temp. 3=Suction temp. 4=Source water delivery temperature	0	0	3/4	-
M	Hc03	S6 configuration 0=Not used 1=Remote set point 2=External temperature	0	0	2	-
S	S041	Defrost: delay at start-up	30	0	999	min
S	S043	Enable sliding defrost: 0/1=No/Yes	0	0	1	-

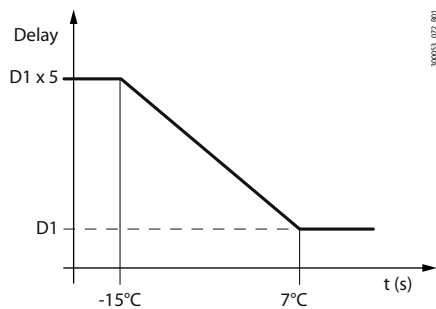

Key

Delay	Calculated defrost start delay
D1	Defrost start delay
D1 x 5	Maximum defrost delay (5 x D1)
Temp	Outside air temperature

Fig. 5.a

5.17.4 Defrost synchronisation

On two-circuit units, the defrosting procedures can be synchronised.

User	Code	Description	Def	Min	Max	UOM
S	S053	Defrost synchronisation 0=Independent 1=Separate 2=Simultaneous	0	0	2	-

Independent

The two circuits start defrosting when the conditions are right, independently of each other. In other words, there is no synchronisation and the circuits can defrost at the same time.

Separate

When the first circuit requires defrosting:

- it starts the defrost procedure;
- the other continues to work in heat pump mode.

When the first circuit has finished defrosting, the other is free to start.

Simultaneous

This procedure is used if the air flow cooling the condenser coils on one circuit affects the other: during the defrost phase this would mean a considerable waste of energy to recover the heat lost in the air flow on the other circuit. The first circuit that requires defrosting thus puts the entire unit into defrost mode. If only one circuit starts defrosting, it completes all the defrost phases while the other remains off. If the other circuit one requires defrosting but is waiting until the defrost start delay elapses, the delay is ignored and the circuit also starts defrosting. When one of the circuits reaches the end defrost condition, it remains in the dripping phase until the other circuit ends the procedure. In this way, the dripping phase is performed by both circuits, preventing the air flow to the condenser coils from affecting the defrost procedure. During this phase, the compressor is stopped instead of operating at end defrost capacity, to prevent the waiting phase of the other compressor from bringing the user terminals to excessively low temperatures.

🔍 **Note:** if there is a common air circuit for the condensers, simultaneous defrosting is enabled automatically.

5.18 4-way valve management

A special function has been included to ensure correct control of the 4-way valve that reverses the refrigerating cycle. When there is a request to reverse the valve, the controller checks whether the pressure difference is higher than a threshold before activating the valve: if the difference is lower, the application waits until the compressor starts and then activates the valve when the pressure difference is reached.

User	Code	Description	Def	Min	Max	UOM
M	S054	4-way valve: pressure differential for reversing	3.0	0.0	999.9	bar

In the event of a power failure, the controller realigns the 4-way valve with the physical position of the valve at next start-up, considering the status of the circuit at the time of the power failure.

5.19 Manual device management

In the menu relating to the individual devices, operation of the individual actuators fitted on the unit can be switched from automatic to manual. For digital outputs, the options are ON or OFF, while analogue outputs can be set from 0 to 100%; the default values are all Auto.

User	Code	Description	Def	Min	Max	UOM
S	E000	ExV circuit 1: manual mode 0/1=No/Yes	0	0	1	-
S	E001	ExV circuit 1: steps in manual mode	0	0	65535	steps
S	E002	ExV circuit 2: manual mode 0/1=No/Yes	0	0	1	-
S	E003	ExV circuit 2: steps in manual mode	0	0	65535	steps
S	U002	User pump 1: operating mode 0=AUTO; 1=OFF; 2=ON	0	0	2	-
S	U005	User pump 2: operating mode 0=AUTO; 1=OFF; 2=ON	0	0	2	-
S	C002	Comp. 1 circuit 1: operating mode 0=AUTO; 1=OFF; 2=ON	0	0	2	-
S	C005	Comp. 2 circuit 1: operating mode 0=AUTO; 1=OFF; 2=ON	0	0	2	-
S	C008	Comp. 1 circuit 2: operating mode 0=AUTO; 1=OFF; 2=ON	0	0	2	-
S	C011	Comp. 2 circuit 2: operating mode 0=AUTO; 1=OFF; 2=ON	0	0	2	-
S	S002	Source pump 1: operating mode 0=AUTO; 1=OFF; 2=ON	0	0	2	-
S	S011	Source modulating fan circuit 1: operating mode 0=AUTO; 1=0%; 2=1%, .. ; 101=100%	0	0	101	-
S	S014	Source ON/OFF fan 1 circuit 2: operating mode 0=AUTO; 1=OFF; 2=ON	0	0	2	-
S	S015	Source modulating fan circuit 2: operating mode 0=AUTO; 1=0%; 2=1%, .. ; 101=100%	0	0	101	-

These operations bypass temperature control, but not the alarm thresholds set to protect unit safety; in general, these operations are used to test the individual actuators during installation.

Manual operation of the devices is described below:

Device	Notes
Compressors	Safety times taken into account All compressor alarms are enabled
User pumps	Pump overload and flow alarm active
Source pump	-
Defrost	-
Source fans	Speed-up disabled
ExV	All alarms disabled

5.20 Air/air unit management (Legacy model only)

The µChiller Legacy version can manage air/air units, both cooling only and reverse cycle. The type of unit is selected via parameter U077, which in the Legacy model can be set as Air/Air CH or Air/Air CH/HP.

On these units, the control probes have the following meaning:

Sensor	Meaning
System water return temperature	Room air return temperature
System water delivery temperature	Air supply temperature

Air supply limit management in cooling mode

A function is used to limit the air supply temperature. When the air supply temperature falls below a certain threshold, set for parameter F009, in the band defined by parameter F010, the control ramp is limited proportionally.

User	Code	Description	Def	Min	Max	UOM
S	F009	Minimum air supply temp. limit: set point	14.0	0	99.9	°C
S	F024	Manual control of heater 1 0=AUTO, 1=OFF, 2=ON	0	0	2	-
S	F025	Manual control of heater 2 0=AUTO, 1=OFF, 2=ON	0	0	2	-
S	F010	Minimum air supply temp. limit: proportional band	4	1	20	K

5.20.1 User fan

On air/air units, the user pump is replaced by a user fan. The water flow switch alarm is used as an air flow switch alarm.

Fan control is subject to the following conditions:

- parameter F017
If F017 = 0, it follows standard mode, i.e. unit on -> fan on.
If F017 = 1, the fan follows the temperature control request and remains off until there is a temperature control request.
- Hot-start and hot-keep functions

The user fan will be activated as shown in the following table:

Unit status	Mode	Control status	Parameter F017	Hot-start	Hot-keep	Fan status
OFF	Not considered	Not considered	Not considered	Not considered	Not considered	OFF (switch-off delay after compressor and/or heater off U048)
ON	Cooling	Not considered	FALSE	Disabled	ON	ON
ON	Cooling	Off	TRUE	Disabled	OFF	OFF
ON	Cooling	On call	TRUE	Disabled	ON	ON
ON	Cooling	Not considered	Not considered	Enabled	ON	ON
ON	Heating	Off	Not considered	Enabled	OFF	OFF
ON	Heating	On call	Not considered	Enabled	ON	ON on Hot-Start function command

Tab. 5.c

User	Code	Description	Def	Min	Max	UOM
S	F017	Main fan: activation mode 0=always On, 1=ON from control	0	0	1	-

Hot-start and Hot-keep functions

These functions are only active in heating mode.

The Hot-Start function is active on air/air units in heating mode only. The function keeps the fan off until the condensing temperature reaches a set point (parameter F018) to avoid sending cold air into the room. If the condensing pressure or condensing temperature probe is not fitted, control is based on the air supply temperature. If the electric heaters are activated, the fan is switched on immediately.

The Hot-keep function has two modes:

- in heating mode, if the compressors and/or heaters are off, the fan remains on until the condensing temperature is greater than the hot-start set point (parameter F018) minus the differential set for parameter F019.
- in cooling mode, the fan will be switched off after the time set for parameter U048, after the compressor and/or heater has been deactivated.

User	Code	Description	Def	Min	Max	UOM
S	F018	Hot-start: set point	40.0	0	99.9	°C
S	F019	Hot-keep: differential	5.0	0	99.9	K

Temperature set point for deactivating the compressors

To avoid energy efficiency below that of electric heaters, the compressors are deactivated if the outside temperature falls below F026, with a fixed reactivation differential of 1 degree. The heaters are activated according to the corresponding set points. Setting F026 to "-40°C" (default value) disables the function.

User	Code	Description	Def	Min	Max	UOM
S	F026	Compressor deactivation due to low outside air temperature	-40	-40	99.9	°C

5.20.2 Heater management on air-air units

This function is only active when the unit is on - main fan on and control active or in defrost.

The type of control is set using parameter F028:

- room temperature (F028 = 0)
- air supply temperature (F028 = 1)

The user can set two different offsets, one in cooling mode and one in heating mode.

The offset is a value that is subtracted from the current set point in cooling mode, or added to the current set point in heating mode. A differential can also be set to define the activation/deactivation temperature of the two heater steps.

Electric heaters can be activated during defrosting. If this function is activated by the user, the heaters remain on for the entire duration of the defrost, including the dripping and post-dripping phases.

Operation of the electric heaters follows the scheme shown below.

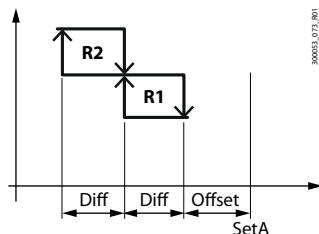

Fig. 5.ae

User	Code	Description	Def	Min	Max	UOM
M	F012	Offset on set point in cooling mode for the heaters	1.0	0.0	99.9	°K
M	F013	Differential on set point in cooling mode for the heaters	0.5	0.2	99.9	°K
M	F014	Offset on set point in heating mode for the heaters	3.0	0.0	99.9	°K
M	F015	Differential on set point in heating mode for the heaters	1.0	0.2	99.9	°K
M	F016	Heaters active during defrost (0= No, 1=Yes)	0	0	1	-
M	F028	Air heating: probe for user heater temperature control 0 = ROOM 1 = SUPPLY	0	0	1	-

5.21 Automatic heater management for water units (Legacy model only)

The uChiller Legacy version can manage auxiliary heaters as part of the main control, even on air/water and water/water units.

The function is active

- only when the unit is on
- with the fan/pump on
- only in heating mode
- when control is active

The heater control diagram is the same as shown in par. 5.20.2 for air/air units.

The control set point (SetH) and probe are the same used for the main control.

An offset (F014) and differential (F015) can be set to define the auxiliary heater activation/deactivation limits.

Example: The following figure shows the control diagram with one auxiliary heater only.

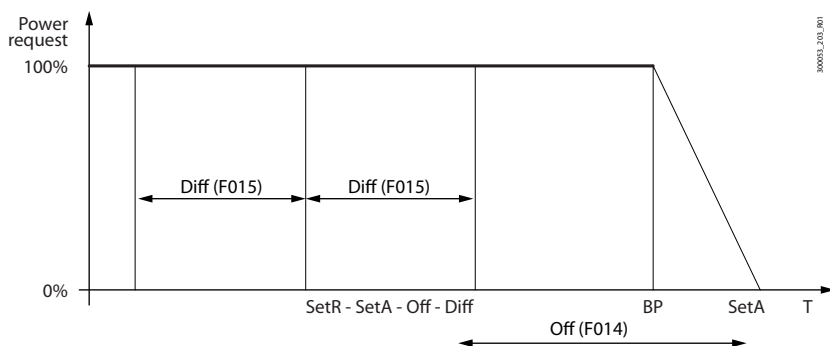

Fig. 5.af

The auxiliary heater works mainly to supplement the main control, but also remains active for frost protection. In the event of frost protection, when both auxiliary and frost protection heaters are installed, both outputs will be active.

Up to two heaters are available, however with the following configuration required:

- heater 1 configured on circuit 1
- heater 2 configured on circuit 2 using the I/O expansion

Code	Description	Def	Min	Max	UOM
F014	Offset on set point in heating mode for the heaters	3.0	0.0	99.9	°K
F015	Differential on set point in heating mode for the heaters	1.0	0.2	99.9	°K
F016	Heaters active during defrost (0= No, 1=Yes)	0	0	1	-
F028	Air heating: probe for user heater temperature control 0 = ROOM 1 = SUPPLY	0	0	1	-

Tab. 5.l

5.22 Condensing unit management

µChiller can manage condensing units with one or two circuits, air- or water-cooled, in cooling-only mode or reverse cycle with defrost. The mode is set using parameter U077.

Compared to a chiller unit, the condensing unit does not manage circulation of the primary fluid (pump, flow switch, etc.)

The control signal can be sent to the condensing unit in two ways:

- via BMS (not available on Legacy models)
- via digital inputs

Request via BMS

The request is written by an external device to register HR 331. If the unit is offline, the request is overridden to 0% and the devices are turned off.

Request via digital inputs

There is a digital input for each compressor. Activation of the digital input corresponds to a control step request. The µChiller application manages rotation between steps, stop due to alarms, and timings.

For Legacy models only, the direct relationship between request digital inputs and compressor digital outputs can be set using parameter F023. In this case, rotation of the steps must be managed externally.

User	Code	Description	Def	Min	Max	UOM
S	F023	Direct relationship DI - compressor DO (MC only) 0=No, 1=Yes	0	0	1	-

5.23 Automatic changeover (Legacy model only)

This function is used to switch automatically between cooling/heating modes based on the selected probe.

When automatic changeover is enabled, summer/winter seasons are ignored..

The function is only available for the Legacy model.

The following table shows the parameters used to manage this function.

Code	Description	Def	Min	Max	UOM
U083	Changeover type 0: disabled 1: outside air temperature; 2: air return temperature (air/air units only) 3: delivery water temperature (air/water or water/water units only)	0	0	3	-
U084	Changeover threshold (type 1 only)	23	-99.9	99.9	°C/F
U085	Changeover dead zone	2	0	99.9	°C/F
U086	Automatic changeover set point minimum limit	0	-99.9	999.9	°C/F
U087	Automatic changeover set point maximum limit	80	-99.9	999.9	°C/F
U035	Automatic changeover delay	15	0	999	Min
SEtU	Automatic changeover set point (types 2 and 3 only)	23	U086	U087	°C/F

Tab. 5.d

The operating mode selection diagrams are shown for each single case.

5.23.1 Mode 1: outside air temperature;

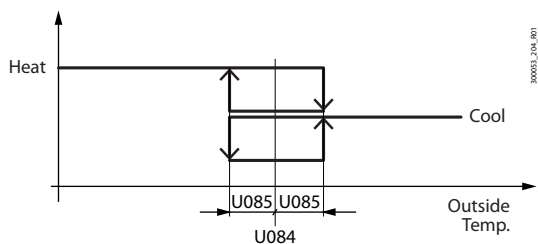

If automatic changeover is set based on the outside temperature, the main temperature control will use the probes configured for U036 (start-up) and Uo38 (running) and the set points SetC (cooling) and SetH (heating).

Fig. 5.b

5.23.2 Mode 2: air return temperature (A/A units)

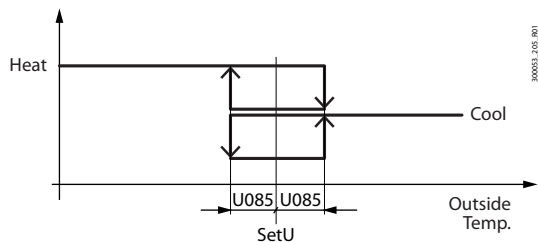

If the automatic changeover is set based on the air return temperature, the main temperature control will also use the same set point SetU for changeover.

Fig. 5.c

5.23.3 Mode 3: delivery water temperature (A/W and W/W units)

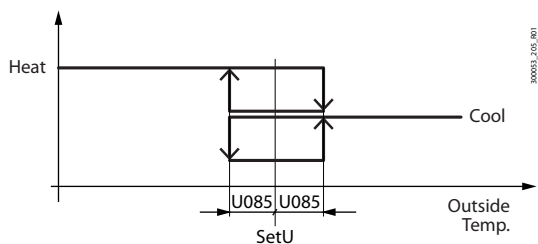

If the automatic changeover is set based on the delivery water temperature, the main temperature control will also use the same set point SetU for changeover.

Fig. 5.d

6. PARAMETER TABLE

Notes:

- Levels: U=User; S=Service; M=Manufacturer; Display: the x indicates that the parameter can be accessed from the display terminal;
- R/W=read/write parameters; R=read-only parameters.

6.1 System

User	Display	Code	Description	Def.	Min.	Max.	UOM	R/W	Modbus
Plt = System									
S		U000	User pump 1: maintenance hour threshold (x100)	99	0	999	h	R/W	HR002
S		U001	User pump 1: reset hour counter	0	0	1	-	R/W	CS000
S	x	U002	User pump 1: operating mode 0=AUTO - 1=OFF - 2=ON	0	0	2	-	R/W	HR003
S		U003	User pump 2: maintenance hour threshold (x100)	99	0	999	h	R/W	HR004
S		U004	User pump 2: reset hour counter	0	0	1	-	R/W	CS001
S	x	U005	User pump 2: operating mode 0=AUTO - 1=OFF - 2=ON	0	0	2	-	R/W	HR005
S		U006	Cooling set point: minimum limit	5.0	-99.9	999.9	°C/°F	R/W	HR007 (2R)
S		U007	Cooling set point: maximum limit	20.0	-99.9	999.9	°C/°F	R/W	HR009 (2R)
S		U008	Heating set point: minimum limit	30.0	0.0	999.9	°C/°F	R/W	HR01 (2R)
S		U009	Heating set point: maximum limit	45.0	0.0	999.9	°C/°F	R/W	HR011 (2R)
S		U010	Enable set point compensation - 0/1=no/yes	0	0	1	-	R/W	CS002
S		U011	Cooling compensation: start	25.0	-99.9	999.9	°C/°F	R/W	HR015 (2R)
S		U012	Cooling compensation: end	35.0	-99.9	999.9	°C/°F	R/W	HR017 (2R)
S		U013	Cooling compensation: maximum value	5.0	-99.9	999.9	K/R	R/W	HR019 (2R)
S		U014	Heating compensation: start	5.0	-99.9	999.9	°C/°F	R/W	HR021 (2R)
S		U015	Heating compensation: end	-10	-99.9	999.9	°C/°F	R/W	HR023 (2R)
S		U016	Heating compensation: maximum value	5.0	-99.9	999.9	K/R	R/W	HR025 (2R)
S		U017	Enable time band - 0/1=No/Yes	0	0	1	-	R/W	CS003
S		U018	Time band: start hours	17	0	23	h	R/W	HR027
S		U019	Time band: start minutes	30	0	59	min	R/W	HR028
S		U020	Time band: end hours	7	0	23	h	R/W	HR029
S		U021	Time band: end minutes	0	0	59	min	R/W	HR030
S		U022	Type of changeover in time band 0=Off - 1=2nd set point	0	0	1	-	R/W	CS004
U	x	U023	2nd cooling set point	10.0	U006	U007	°C/°F	R/W	HR031(2R)
U	x	U024	2nd heating set point	35.0	U008	U009	°C/°F	R/W	HR033(2R)
S		U025	Remote set point: analogue input 0=0-5V - 1=0-10V - 2=4-20 mV	0	0	2	-	R/W	HR035
S		U026	Remote set point: min value	5.0	-99.9	999.9	°C/°F	R/W	HR037(2R)
S		U027	Remote set point: max value	35.0	-99.9	99.9	°C/°F	R/W	HR039(2R)
S		U028	Remote set point: offset	0.0	-99.9	99.9	K/R	R/W	HR043(2R)
S	x	U031	High water temp. alarm: offset	10.0	0.0	99.9	K/R	R/W	HR049(2R)
S	x	U032	High water temp. alarm: delay at start-up	15	0	99	min	R/W	HR051
S	x	U033	High water temp. alarm: delay in operation	180	0	999	s	R/W	HR052
S		U034	Operating mode changeover 0=Keypad - 1=Digital input	0	0	1	-	R/W	CS005
S		U035	Cooling/heating changeover: delay	15	0	999	min	R/W	HR053
S		U036	Control probe at start-up 0=Return - 1=Delivery	0	0	1	-	R/W	CS006
S		U037	PID control delay at start-up/operation	180	0	999	s	R/W	HR054
S		U038	Control probe in operation 0=Return - 1=Delivery	1	0	1	-	R/W	CS007
S		U039	PID at start-up: Kp	10.0	0.0	999.9	-	R/W	HR055(2R)
S		U040	PID at start-up: Ti - 0: integral action disabled	180	0	999	s	R/W	HR057
S		U041	PID at start-up: Td - 0: derivative action disabled	0	0	99	s	R/W	HR058
S		U042	PID in operation: Kp	10.0	0.0	999.9	-	R/W	HR059(2R)
S		U043	PID in operation: Ti 0: integral action disabled	120	0	999	s	R/W	HR061
S		U044	PID in operation: Td 0: derivative action disabled	3	0	99	s	R/W	HR062
S		U045	User pump flow alarm: delay at start-up	10	0	999	s	R/W	HR063
S		U046	User pump flow alarm: delay in operation	3	0	99	s	R/W	HR064
S		U047	Compressor activation delay after user pump	30	0	999	s	R/W	HR065
S		U048	User pump shutdown delay after compressor	180	0	999	s	R/W	HR066
S		U049	User pump rotation time	12	0	999	h	R/W	HR067
S		U050	User side frost protection: alarm threshold	-0.8	-99.9	999.9	°C/°F	R/W	HR068 (2R)
S		U051	User side frost protection: differential	30.0	0.0	999.9	K/R	R/W	HR070 (2R)
S		U052	User-side frost protection: delay time at 1K	30	0	999	s	R/W	HR072
S		U053	Unit OFF: frost protection set point	4.0	-99.9	999.9	°C/°F	R/W	HR073 (2R)
S		U054	Unit OFF: frost protection differential	2.0	0.0	99.9	K/R	R/W	HR075 (2R)
S		U055	User side return temp. probe: offset	0.0	-99.9	99.9	K/R	R/W	HR079 (2R)

User	Display	Code	Description	Def.	Min.	Max.	UOM	R/W	Modbus
S		U056	User side delivery temp. probe: offset	0.0	-99.9	99.9	K/R	R/W	HR083 (2R)
S		U057	Remote alarm: input logic - 0/1=NC/NO	0	0	1	-	R/W	CS008
S		U058	Cooling/heating input: logic - 0/1=NO/NC	1	0	1	-	R/W	CS009
S	x	U059	Remote ON/OFF: input logic - 0/1=NO/NC	1	0	1	-	R/W	CS010
S		U060	User pump flow switch: input logic - 0/1=NO/NC	0	0	1	-	R/W	CS011
S		U061	User pump overload protector: input logic 0/1=NO/NC	0	0	1	-	R/W	CS012
S		U062	2nd set point: input logic - 0/1=NO/NC	1	0	1	-	R/W	CS013
M		U063	User pump: output logic - 0/1=NO/NC	0	0	1	-	R/W	CS014
S		U064	Global alarm relay: output logic - 0/1=NO/NC	0	0	1	-	R/W	CS015
S		U065	Free cooling valve: output logic - 0/1=NO/NC	0	0	1	-	R/W	CS016
M		U066	Frost protection heater: output logic - 0/1=NO/NC	0	0	1	-	R/W	CS017
S		U067	Alarm relay configuration - 0/1=Control alarms/All	0	0	1	-	R/W	CS018
S		U068	Free cooling: enable - 0/1=no/yes	0	0	1	-	R/W	CS019
S		U069	Free cooling: activation differential	3.0	0.0	99.9	K/R	R/W	HR085 (2R)
S		U070	Free cooling: hysteresis	1.5	0.0	99.9	K/R	R/W	HR087 (2R)
S		U071	Design free cooling delta T	8.0	0.0	99.9	K/R	R/W	HR089 (2R)
S		U072	Water free cooling: valve closing threshold	5.0	-999.9	999.9	°C/°F	R/W	HR091 (2R)
S		U073	Water free cooling: valve closing differential	3.0	0.0	99.9	K/R	R/W	HR093 (2R)
M		U074	Free cooling type 0=Air - 1=Remote coil - 2=Water	0	0	2	-	R/W	HR095
S		U075	Frost protection type 0=Heater - 1=Pump - 2=Heater/Pump	2	0	2	-	R/W	HR096
M		U076	Number of user pumps	1	1	2	-	R/W	HR097
M		U077	Type of unit 0= CH; 1= HP; 2= CH/HP 3= Condensing unit CH 4= Condensing unit CH/HP	0	0	4	-	R/W	HR098
S		U078	Unit pump in standby: enable On-Off cycles 0/1=No/Yes	0	0	1	-	R/W	CS080
S		U079	Unit pump in standby: On time	3	1	15	min	R/W	HR709
S		U080	Unit pump in standby: Off time	15	3	99	min	R/W	HR710
S		U081	Pressure alarm reset configuration	7	0	7	-	R/W	HR239
M		U082	Frost protection type 0 = Evaporation temperature 1 = Water delivery temperature	0	0	1	-	R/W	CS093
M		U083	Type of automatic changeover 0: disabled 1: on outside temperature 2: on air return temp. (for legacy AA units only) 3: on delivery water temp. (AW and WW units only)	0	0	3	-	R/W	HR6
M		U084	Automatic changeover threshold (type 1 only (U083 = 1))	23	-99.9	99.9	°C/°F	R/W	HR765
		U085	Automatic changeover dead band	2	0	99.9	K/R	R/W	HR772
		U086	Automatic changeover set point lower limit	0	-99.9	999.9	°C/°F	R/W	HR774
		U087	Automatic changeover set point upper limit	80	-99.9	999.9	°C/°F	R/W	HR776
		U088	Frost protection heater position 0 = user 1 = source (WW units only) 2 = user and source (WW units only)	0	0	2	-	R/W	HR769

Tab. 6.a

6.2 Compressor

User	Display	Code	Description	Def.	Min	Max	UOM	R/W	Modbus
CMP = Compressor									
S		C000	Comp. 1 circuit 1: maintenance hour threshold(x100)	99	0	999	h	R/W	HR153
S		C001	Comp. 1 circuit 1: reset hour counter	0	0	1	-	R/W	CS023
S	x	C002	Comp. 1 circuit 1: operating mode -0=AUTO - 1=OFF - 2=ON	0	0	2	-	R/W	HR154
S		C003	Comp. 2 circuit 1: maintenance hour threshold(x100)	99	0	999	h	R/W	HR155
S		C004	Comp. 2 circuit 1: reset hour counter	0	0	1	-	R/W	CS024
S	x	C005	Comp. 1 circuit 2: operating mode 0=AUTO - 1=OFF - 2=ON	0	0	2	-	R/W	HR156
S		C006	Comp. 1 circuit 2: maintenance hour threshold(x100)	99	0	999	h	R/W	HR157
S		C007	Comp. 2 circuit 1: reset hour counter	0	0	1	-	R/W	CS025
S	x	C008	Comp. 2 circuit 1: operating mode 0=AUTO - 1=OFF - 2=ON	0	0	2	-	R/W	HR158
S		C009	Comp. 2 circuit 2: maintenance hour threshold(x100)	99	0	999	h	R/W	HR159
S		C010	Comp. 2 circuit 2: reset hour counter	0	0	1	-	R/W	CS026
S	x	C011	Comp. 2 circuit 2: operating mode 0=AUTO - 1=OFF - 2=ON	0	0	2	-	R/W	HR160
M		C012	Min compressor on time	180	30	999	s	R/W	HR162

User	Display	Code	Description	Def.	Min	Max	UOM	R/W	Modbus
M		C013	Min compressor off time	60	30	999	s	R/W	HR163
M		C014	Min time between consecutive compressor starts	360	300	999	s	R/W	HR164
M		C017	Max high pressure threshold (HP)	65.0	0.0	999.9	°C/°F	R/W	HR324 (2R)
M		C018	Min low pressure threshold (LP)	0.2	-99.9	99.9	bar/psi	R/W	HR326 (2R)
M		C020	Maximum circuit destabilisation time	240	5	999	min	R/W	HR168
M		C021	Circuit capacity distribution (0 = balanced, 1 = grouped)	0	0	1	-	R/W	HR169
S		C022	Circuit 1: discharge temp. offset	0.0	-99.9	99.9	K/R	R/W	HR170 (2R)
S		C023	Circuit 1: suction temp. offset	0.0	-99.9	99.9	K/R	R/W	HR172 (2R)
S		C024	Circuit 2: discharge temp. offset	0.0	-99.9	99.9	K/R	R/W	HR174 (2R)
S		C025	Circuit 2: suction temp. offset	0.0	-99.9	99.9	K/R	R/W	HR176 (2R)
S		C026	Circuit 1: condensation pressure offset	0.0	-99.9	99.9	bar/psi	R/W	HR178 (2R)
S		C027	Circuit 1: evaporation pressure offset	0.0	-99.9	99.9	bar/psi	R/W	HR180 (2R)
S		C028	Circuit 1: condensing temp. offset	0.0	-99.9	99.9	K/R	R/W	HR182 (2R)
S		C029	Circuit 1: evaporation temp. offset	0.0	-99.9	99.9	K/R	R/W	HR184 (2R)
S		C030	Circuit 2: condensation pressure offset	0.0	-99.9	99.9	bar/psi	R/W	HR186 (2R)
S		C031	Circuit 2: evaporation pressure offset	0.0	-99.9	99.9	bar/psi	R/W	HR188 (2R)
S		C032	Circuit 2: condensing temp. offset	0.0	-99.9	99.9	K/R	R/W	HR190 (2R)
S		C033	Circuit 2: evaporation temp. offset	0.0	-99.9	99.9	K/R	R/W	HR192 (2R)
M		C034	HP pressure switch: input logic - 0/1=NC/NO	0	0	1	-	R/W	CS027
M		C035	Compressor overload protector: input logic 0/1=NC/NO	0	0	1	-	R/W	CS028
M		C036	Compressor: output logic - 0/1=NO/NC	0	0	1	-	R/W	CS029
M		C037	Evaporation pressure: probe type 0=0-5V - 1=4-20mA	0	0	1	-	R/W	HR194
M		C038	Evaporation pressure probe: min value	0.0	-1.0	99.9	bar/psi	R/W	HR195 (2R)
M		C039	Evaporation pressure probe: max value	17.3	0.0	99.9	bar/psi	R/W	HR197 (2R)
M		C040	Condensation pressure: probe type - 0=0-5V - 1=4-20mA	0	0	1	-	R/W	HR199
M		C041	Condensation pressure probe: min value	0.0	-1.0	99.9	bar/psi	R/W	HR200 (2R)
M		C042	Condensation pressure probe: max value	45.0	0.0	99.9	bar/psi	R/W	HR202 (2R)
M		C043	Discharge temperature Probe type (0=NTC, 1=NTC-HT)	1	0	1	-	R/W	204
M		C044	Enable destabilisation - 0/1=No/Yes	1	0	1	-	R/W	CS030
S		C045	Refrigerant 3=R407C - 4=R410a - 6=R290 - 10=R744 - 22=R32	4	0	99	-	R	IR038
M		C046	No. of unit circuits	1	1	2	-	R/W	HR206
M		C047	Type of compressors used 0=1 On/Off - 1=2 On/Off - 2=1 BLDC - 3= 1 BLDC+On/Off	0	0	3	-	R/W	HR207
M		C049	LP pressure switch: alarm delay from compressor start If C049 = 0 the alarm is triggered even if the compressors are off. If C049 > 0 the alarm is only triggered when the compressors are on	90	0	999	-	R/W	HR269
M		C050	LP pressure switch: alarm delay in steady operation	15	0	999	-	R/W	HR269
M		C051	HP pressure switch: input logic 0=NC 1=NO	0	0	1	-	R/W	CS76

Tab. 6.b

6.3 BLDC and Inverter

User	Display	Code	Description	Def.	Min	Max	UOM	R/W	Modbus
S		P000	Min evaporation temp.: custom limit	-25.0	-99.9	999.9	°C/°F	R/W	HR335 (2R)
S		P001	Max condensing temp.: custom limit	70.0	-99.9	999.9	°C/°F	R/W	HR337 (2R)
M		P003	Out of envelope alarm delay	120	0	999	s	R/W	HR340
M		P004	Low pressure differential alarm delay	60	0	999	s	R/W	HR341
M		P006	Oil recovery: min request for activation	35.0	0.0	100.0	%	R/W	HR344 (2R)
M		P007	Oil recovery: min speed for activation	35.0	0.0	999.9	rps	R/W	HR346 (2R)
M		P008	Oil recovery: comp. operating time at low speed	15	0	999	min	R/W	HR348
M		P009	Oil recovery: force comp. speed time	3	0	999	min	R/W	HR349
M		P010	Oil recovery: force comp. speed value	50.0	0.0	999.9	rps	R/W	HR350 (2R)
M		P011	Oil equalisation: solenoid valve opening time at start-up	30	0	999	s	R/W	HR352
M		P012	Oil equalisation: solenoid valve opening time	3	0	999	s	R/W	HR353
M		P013	Oil equalisation: min solenoid valve closed time	1	0	999	min	R/W	HR354
M		P014	Oil equalisation: max solenoid valve closed time	15	0	999	min	R/W	HR355
M		P015	Oil equalisation: solenoid valve closed time increment	20	0	999	min	R/W	HR356
S		P016	Oil equalisation valve: output logic - 0/1=NO/NC	0	0	1	-	R/W	CS66
M		P017	Enable oil equalisation valve - 0/1=No/Yes	0	0	1	-	R/W	CS67
M		P018	Enable oil recovery - 0/1=No/Yes	0	0	1	-	R/W	CS68
S	x	P019	BLDC compressor circ.1: operating mode 0=AUTO; 1=0%, ... 101=100%	0	0101-		R/W	HR357	
S	x	P020	BLDC compressor circ.2: operating mode 0=AUTO; 1=0%, ... 101=100%	0	0	101	-	R/W	HR358

User	Display	Code	Description	Def.	Min	Max	UOM	R/W	Modbus
M		P021	Max. deltaP at start-up	900.0	0.0	2000.0	kPa	R/W	HR359 (2R)
M		P022	EVD: max pre-opening time for pressure equalisation	10	0	999	s	R/W	HR361
M		P023	EVD: pre-opening value for pressure equalisation	50.0	0.0	100.0	%	R/W	HR362 (2R)
M		P024	Start-up speed	50.0	20.0	120.0	rps	R/W	HR363 (2R)
M		P025	Custom speed: max value	120.0	0.0	999.9	rps	R/W	HR365 (2R)
M		P026	Custom speed: min value	20.0	0.0	999.9	rps	R/W	HR367 (2R)
S		P030	Skip frequency: centre point [010]	0.0	0.0	999.9	Hz	R/W	HR375 (2R)
S		P031	Skip frequency: band [011]	0.0	0.0	999.9	Hz	R/W	HR377 (2R)
M		P032	Enable motor over-temperature alarm (PTC) [027] - 0/1=No/Yes	0	0	1		R/W	HR379
M		P033	Motor over-temperature delay delay (PTC) [028]	0	0	999	s	R/W	HR380
M		P034	Enable crankcase heater function - 0/1=No/Yes	0	0	1		R/W	CS69

Tab. 6.r

6.4 Valve

User	Display	Code	Description	Def.	Min	Max	UOM	R/W	Modbus
EEU = Valve									
S		E000	ExV circuit 1: manual mode - 0/1=No/Yes	0	0	1	-	R/W	CS020
S		E001	ExV circuit 1: steps in manual mode	0	0	65535	steps	R/W	HR099
S		E002	ExV circuit 2: manual mode - 0/1=No/Yes	0	0	1	-	R/W	CS021
S		E003	ExV circuit 2: steps in manual mode	0	0	65535	steps	R/W	HR100
S	x	E004	SH in cooling: set point	6.0	-40.0	180.0	K/R	R/W	HR101 (2R)
S		E005	SH in cooling: Kp	15.0	0.0	800.0	-	R/W	HR103 (2R)
S		E006	SH in cooling: Ti	150.0	0.0	1000.0	s	R/W	HR105 (2R)
S		E007	SH in cooling: Td	1.0	0.0	800.0	s	R/W	HR107 (2R)
S	x	E008	SH in heating: set point	6.0	-40.0	180.0	K/R	R/W	HR109 (2R)
S		E009	SH in heating: Kp	15.0	0.0	800.0	-	R/W	HR111 (2R)
S		E010	SH in heating: Ti	150.0	0.0	1000.0	s	R/W	HR113 (2R)
S		E011	SH in heating: Td	1.0	0.0	800.0	s	R/W	HR115 (2R)
S		E012	LowSH in cooling: threshold	1.0	-40.0	180.0	K/R	R/W	HR117 (2R)
S		E013	LowSH in cooling: Ti	10.0	0.0	800.0	s	R/W	HR119 (2R)
S		E014	LowSH in heating: threshold	1.0	-40.0	180.0	K/R	R/W	HR121 (2R)
S		E015	LowSH in heating: Ti	10.0	0.0	800.0	s	R/W	HR123 (2R)
S		E016	LOP in cooling: threshold	-5.0	-60.0	200.0	°C/°F	R/W	HR125 (2R)
S		E017	LOP in cooling: Ti	5.0	0.0	800.0	s	R/W	HR127 (2R)
S		E018	LOP in heating: threshold	-50.0	-60.0	200.0	°C/°F	R/W	HR129 (2R)
S		E019	LOP in heating: Ti	5.0	0.0	800.0	s	R/W	HR131 (2R)
M		E020	MOP in cooling: threshold	30.0	-60.0	200.0	°C/°F	R/W	HR133 (2R)
M		E021	MOP in cooling: Ti	15.0	0.0	800.0	s	R/W	HR135 (2R)
M		E022	MOP in heating: threshold	20.0	-60.0	200.0	°C	R/W	HR137 (2R)
M		E023	MOP in heating: Ti	15.0	0.0	800.0	s	R/W	HR139 (2R)
M		E024	LowSH: alarm delay time	300	0	18000	s	R/W	HR141
M		E025	LOP: alarm delay time	300	0	18000	s	R/W	HR142
M		E026	MOP: alarm delay time	300	0	18000	s	R/W	HR143
M		E032	Valve opening % at start-up (EVAP/EEV capacity ratio) in cooling	100	0	100	%	R/W	HR144
M		E033	Valve opening % at start-up (EVAP/EEV capacity ratio) in heating	100	0	100	%	R/W	HR145
M		E034	Control delay after pre-positioning	6	3	18000	s	R/W	HR146
M		E046	EVD Evolution: valve (1=CAREL EXV, ...) (*)	1	1	35	-	R/W	HR048
S		E047	ExV driver (0=Disabled, 1=Built-in, 2=EVD Evolution)	0	0	2	-	R/W	HR328

Tab. 6.c

☛ Note: (*) see the EVD Evolution manual for the complete list of selectable valves.

6.5 Source

User	Display	Code	Description	Def.	Min	Max	UOM	R/W	Modbus
Src = Source									
S		S000	Source pump 1: maintenance hour threshold (x100)	99	0	999	h	R/W	HR209
S		S001	Source pump 1: reset hour counter	0	0	1	-	R/W	CS031
S	x	S002	Source pump 1: operating mode 0=AUTO - 1=OFF - 2=ON	0	0	2	-	R/W	HR210
S		S008	Source fan 1 circuit 1: maintenance hour threshold (X100)	99	0	999	h	R/W	HR214
S		S009	Source fan 1 circuit 1: reset hour counter	0	0	1	-	R/W	CS033
S	x	S010	Source ON/OFF fan 1 circuit 1: operating mode - 0=AUTO - 1=OFF - 2=ON	0	0	2	-	R/W	HR215
S	x	S011	Source modulating fan circuit 1: operating mode - 0=AUTO - 1=0% - 2=1%, ..101=100%	0	0	101	-	R/W	HR216

User	Display	Code	Description	Def.	Min	Max	UOM	R/W	Modbus
S		S012	Source fan 1 circuit 2: maintenance hour threshold (X100)	99	0	999	h	R/W	HR217
S		S013	Source fan 1 circuit 2: reset hour counter	0	0	1	-	R/W	CS034
S	x	S014	Source ON/OFF fan circuit 2: operating mode 0=AUTO - 1=OFF - 2=ON	0	0	2	-	R/W	HR218
S	x	S015	Source modulating fan circuit 2: operating mode 0=AUTO - 1=0% - 2=1%, ..101=100%	0	0	101	-	R/W	HR219
S		S016	Source fan: cold climate temperature threshold	-0.5	-999.9	999.9	°C/°F	R/W	HR220 (2R)
S		S017	Source fan: min cold climate speed	10.0	0.0	100.0	%	R/W	HR222 (2R)
S		S018	Source fan: cold climate speed at start-up	50.0	0.0	100.0	%	R/W	HR224 (2R)
S		S019	Source fan: cold climate speed at start-up time	5	0	300	s	R/W	HR226
S	x	S020	Enable noise reduction - 0/1=No/Yes	0	0	1	-	R/W	CS035
S		S021	Noise reduction time band: start hours	22	0	23	h	R/W	HR167
S		S022	Noise reduction time band: start minutes	30	0	59	min	R/W	HR212
S		S023	Noise reduction time band: end hours	8	0	23	h	R/W	HR041
S		S024	Noise reduction time band: end minutes	30	0	59	min	R/W	HR042
S		S025	Source fan: noise reduction set point	45.0	0.0	999.9	°C/°F	R/W	HR231 (2R)
S		S026	Compressor start delay after pump start	30	0	999	s	R/W	HR233
S		S027	Pump shutdown delay after compressor off	10	0	999	s	R/W	HR234
S		S028	Source fan in cooling: set point	30.0	-999.9	999.9	°C/°F	R/W	HR235 (2R)
S		S029	Source fan in heating: set point	10.0	0.0	99.9	°C/°F	R/W	HR237 (2R)
S		S031	Source fan in cooling: set point at start-up	45.0	0.0	999.9	°C/°F	R/W	HR241 (2R)
S		S032	Source fan: delay at start-up in cooling	240	0	999	s	R/W	HR243
S		S034	Source fan: differential in cooling	15.0	0.0	99.9	K	R/W	HR246 (2R)
S		S035	Source fan: differential in heating	5.0	0.0	99.9	K	R/W	HR248 (2R)
S		S036	Modulating source fan: min speed value	20.0	0.0	100.0	%	R/W	HR250 (2R)
S		S037	Modulating source fan: max speed value	80.0	0.0	100.0	%	R/W	HR252 (2R)
S		S039	Defrost: start temperature	-1.0	-99.9	99.0	°C/°F	R/W	HR254 (2R)
S		S040	Defrost: reset start defrost delay threshold	1.0	S039	99.9	°C/°F	R/W	HR256 (2R)
S		S041	Defrost: delay at start-up	30	0	999	min	R/W	HR258
S		S042	Defrost: end temperature	52.0	-999.9	999.9	°C/°F	R/W	HR259 (2R)
S		S043	Enable sliding defrost - 0/1=No/Yes	0	0	1	-	R/W	CS037
S		S044	Operation time at min capacity before cycle reversing	20	0	999	s	R/W	HR261
S		S045	Operation time at min capacity after cycle reversing	30	0	999	s	R/W	HR262
S		S046	Defrost: min duration	1	0	99	min	R/W	HR263
S		S047	Defrost: max duration	5	0	99	min	R/W	HR264
S		S048	Dripping: duration - 0=Dripping not performed	90	0	999	s	R/W	HR265
S		S049	Post-dripping: duration - 0=Post-dripping not performed	30	0	999	s	R/W	HR266
S		S050	Minimum delay between consecutive defrosts	20	0	999	min	R/W	HR267
S		S051	BLDC compressor speed in defrost	80.0	0.0	999.9	rps	R/W	HR382 (2R)
S		S052	BLDC compressor speed for cycle reversing in defrost	40.0	0.0	999.9	rps	R/W	HR384 (2R)
S		S053	Defrost synchronisation - 0=Independent - 1=Separate - 2=Simultaneous	0	0	2	-	R/W	HR272
M		S054	4-way valve: pressure differential for reversing	3.0	0.0	999.9	bar/psi	R/W	HR274 (2R)
M		S055	Compressor after defrost - 0/1=On/Off	0	0	1	-	R/W	CS038
S		S056	BLDC smart start: duration (*)	20	0	999	s	R/W	HR278
S		S057	Source frost protection: alarm threshold	-0.8	-999.9	999.9	K/R	R/W	HR279 (2R)
S		S058	Source frost protection: alarm differential	30.0	0.0	999.9	K/R	R/W	HR281 (2R)
S		S059	Frost protection alarm delay at threshold -1K	30	0	999	s	R/W	HR283
S		S060	Source: outside air temperature probe offset	0.0	-99.9	99.9	K/R	R/W	HR284 (2R)
M		S061	Source fan: output logic - 0/1=NO/NC	0	0	1	-	R/W	CS039
M		S062	Source pump: output logic - 0/1=NO/NC	0	0	1	-	R/W	CS040
S		S063	Reversing valve: output logic - 0/1=NO/NC	0	0	1	-	R/W	CS041
S		S064	Type of source air circuit 0=Independent - 1=Common	0	0	1	-	R/W	CS042
S		S065	Type of source fan - 0/1=Modulating/ON-OFF	0	0	1	-	R/W	CS044
S		S068	Unit type - 0=Air - 1=Water	0	0	1	-	R/W	CS046
S		S069	Defrost with fans: outside temperature threshold 0.0°C/32.0°F=Function disabled	0.0	0.0	99.9	-	R/W	HR736
S		S072	Source pump activation 0=on with unit on 1=on with compressor on 2=modulating on/off with condensing temperature	0	0	2	-	R/W	HR213
S		S073	Compressor status at start defrost 0=On minimum speed - 1=Off	0	0	1	-	R/W	CS92

Tab. 6.d

6.6 Input/output configuration

User	Display	Code	Description	Def.	Min	Max	UOM	R/W	Modbus
S		Hc31	S1 configuration	7	0	8	-	R/W	HR752
S		Hc32	S2 configuration	8	0	8	-	R/W	HR753
S		Hc00	S3 configuration	0	0	8	-	R/W	HR286
		S008	Source fan 1 circuit 1 maintenance hour threshold (x100)	99	0	999	h	R/W	HR214
M		Hc01	S4 and S5 configuration 0=Pressure - 1=Temperature	0	0	1	-	R/W	HR287
M		Hc02	Enable S4 0/1=No/Yes	1	0	1	-	R/W	CS048
S		Hc34	S4 configuration	7	0	10	-	R/W	HR754
S		Hc35	S5 configuration	8	0	10	-	R/W	HR755
S		Hc03	S6 configuration	0	0	11	-	R/W	HR288
S		Hc04	S7 configuration (DIN)	6	0	8	-	R/W	HR289
S		Hc41	S1 configuration (Circuit 2)	0	0	8	-	R/W	HR756
S		Hc42	S2 configuration (Circuit 2)	0	0	8	-	R/W	HR757
S		Hc43	S3 configuration (Circuit 2)	0	0	8	-	R/W	HR758
S		Hc44	S4 configuration (Circuit 2)	7	0	10	-	R/W	HR759
S		Hc45	S5 configuration (Circuit 2)	8	0	10	-	R/W	HR760
S		Hc05	S6 configuration (Circuit 2)	0	0	11	-	R/W	HR290
S		Hc47	S7 configuration (Circuit 2)	6	0	8	-	R/W	HR761
S		Hc14	ID1 configuration	1	0	10	-	R/W	HR297
S		Hc15	ID2 configuration	2	0	10	-	R/W	HR298
S		Hc06	ID4 configuration	0	0	10	-	R/W	HR291
S		Hc07	ID5 configuration	7	0	10	-	R/W	HR292
S		Hc08	ID6 configuration	6	0	10	-	R/W	HR293
S		Hc16	ID1 configuration (Circuit 2)	10	0	10	-	R/W	HR299
S		Hc17	ID2 configuration (Circuit 2)	2	0	10	-	R/W	HR300
S		Hc09	ID4 configuration (Circuit 2)	0	0	10	-	R/W	HR294
S		Hc10	ID5 configuration (circuit 2)	0	0	10	-	R/W	HR295
S		Hc11	ID6 configuration (Circuit 2)	0	0	10	-	R/W	HR296
S		Hc51	NO1 configuration	1	0	11	-	R/W	HR740
S		Hc52	NO2 configuration	2	0	11	-	R/W	HR741
S		Hc53	NO3 configuration	4	0	11	-	R/W	HR742
S		Hc54	NO4 configuration	7	0	11	-	R/W	HR743
S		Hc55	NO5 configuration	10	0	11	-	R/W	HR744
S		Hc56	NO6 configuration	0	0	11	-	R/W	HR745
S		Hc61	NO1 configuration (Circuit 2)	1	0	8	-	R/W	HR746
S		Hc62	NO2 configuration (Circuit 2)	2	0	8	-	R/W	HR747
S		Hc63	NO3 configuration (Circuit 2)	4	0	8	-	R/W	HR748
S		Hc64	NO4 configuration (Circuit 2)	7	0	8	-	R/W	HR749
S		Hc65	NO5 configuration (Circuit 2)	0	0	8	-	R/W	HR750
S		Hc66	NO6 configuration (Circuit 2)	0	0	8	-	R/W	HR751
S		Hc71	Y1 configuration	1	0	3	-	R/W	HR240
S		Hc72	Y2 configuration	3	0	3	-	R/W	HR245
S		Hc81	Y1 configuration (Circuit 2)	1	0	2	-	R/W	HR244
S		Hc82	Y2 configuration (Circuit 2)	0	0	2	-	R/W	HR276
S		Hc13	Buzzer 0/1=No/Yes	0	0	1	-	R/W	CS050

Tab. 6.e

➡ Note: (1) Max = 3 with Panel model, Max = 2 with DIN model.

6.7 mCH2 parameters (Legacy models only)

User	Display	Code	Description	Def.	Min	Max	UOM	R/W	Modbus
M	X	F027	Compressors at part load (0=NO, 1=YES)	0	0	1	-	-	-
M	X	F003	Number of evaporators (0=1; 1=2)	0	0	1	-	-	-
M	X	F007	Probe S4 installed on the source heat exchanger (0=No, 1=Yes: condensing in CH mode, evaporation in HP mode)	0	0	1	-	-	-
M	X	F008	Frost protection alarm delay	10	0	999	-	-	-
M	X	F009	Supply air temperature limit threshold	14.0	0.0	99.9	°C	-	-
M	X	F010	Supply air temperature limit differential	4.0	0.0	20.0	°K	-	-
M	X	F011	Heater digital output logic (0=NO; 1=NC)	0	0	1	-	-	-
M	X	F012	Offset on set point in cooling mode for the heaters	1.0	0.0	99.9	°K	-	-
M	X	F013	Differential on set point in cooling mode for the heaters	0.5	0.2	99.9	°K	-	-
M	X	F014	Offset on set point in heating mode for the heaters	3.0	0.0	99.9	°K	-	-
M	X	F015	Differential on set point in heating mode for the heaters	1.0	0.2	99.9	°K	-	-

User	Display	Code	Description	Def.	Min	Max	UOM	R/W	Modbus
M	X	F016	Heaters active during defrost (0=No, 1=Yes)	0	0	1	-	-	-
M	X	F017	Supply fan operating mode (0=Always ON; 1=ON by temp. control)	0	0	1	-	-	-
M	X	F018	Hot-start set point	40.0	0.0	99.9	°C	-	-
M	X	F019	Hot-keep differential	5.0	0.0	99.9	°K	-	-
M	X	F020	Compressor request logic from digital input (0=NC; 1=NO)	1	0	1	-	-	-
M	X	F021	Mix delivery water temperature probe calibration (S1 expansion)	0.0	-99.9	99.9	°K	-	-
M	X	F022	Evaporator 2 water outlet temperature probe calibration (S2 expansion)	0.0	-99.9	99.9	°K	-	-
M	X	F023	Direct relationship between digital inputs and digital outputs for condensing unit (0=No; 1=Yes)	0	0	1	-	-	-
M	X	F024	Manual heater 1 management (0=AUTO; 1=OFF; 2=ON)	0	0	2	-	-	-
M	X	F025	Manual heater 2 management (0=AUTO; 1=OFF; 2=ON)	0	0	2	-	-	-
M	x	F026	Compressors off at low outside temperature (air/air)	-40.0	-40.0	99.9	°C	-	-
M		F027	Enable compressor capacity control 0/1=No/Yes	0	0	1	-	R/W	CS49
M		F028	Air heating: probe for user heater temperature control 0 = ROOM - 1 = SUPPLY	FALSE	-	-	-	R/W	CS94

Tab. 6.f

6.8 BMS port

User	Display	Code	Description	Def.	Min	Max	UOM	R/W	Modbus
S	x	Hd00	BMS: serial address	1	1	247	-	-	HR147
S	x	Hd01	BMS: baud rate 3=9600; 4=19200; 5=38400; 6=57600; 7=115200	7	3	7	-	-	HR148
S	x	Hd02	BMS: settings 0= 8-NONE-1 - 1= 8-NONE-2 - 2= 8-EVEN-1 3= 8-EVEN-2 - 4= 8-ODD-1 - 5= 8-ODD-2	1	0	5	-	-	HR149
S	x	Hd07	BMS: supervisor database 0= 32bit 1= 16bit	0	0	1	-	-	CS48

Tab. 6.g

6.9 Password

User	Display	Code	Description	Def.	Min	Max	UOM	R/W	Modbus
U		He00	User password	1000	0000	9999	-	-	-
S		He01	Service password	2000	0000	9999	-	-	-
M		He02	Manufacturer password	1234	0000	9999	-	-	-
M		He03	Password for profile 1	0001	0000	9999	-	-	-
M		He04	Password for profile 2	0002	0000	9999	-	-	-
M		He05	Password for profile 3	0003	0000	9999	-	-	-
M		He06	Password for profile 4	0004	0000	9999	-	-	-
M		He07	Password for profile 5	0005	0000	9999	-	-	-
M		He08	Password for profile 6	0006	0000	9999	-	-	-
M		He09	Password for profile 7	0007	0000	9999	-	-	-

Tab. 6.h

6.10 Dashboard values

User	Display	Code	Description	Def.	Min	Max	UOM	R/W	Modbus
U	x	AFC1	Circuit 1: source water delivery temperature	-	-999.9	999.9	°C/°F	R	IR217 (2R)
U	x	AFC2	Circuit 2: source water delivery temperature	-	-999.9	999.9	°C/°F	R	IR213 (2R)
U	x	EuP1	Circuit 1: evaporation temperature (or converted value)	-	-999.9	999.9	°C/°F	R	IR026 (2R)
U	x	EuP2	Circuit 2: evaporation temperature (or converted value)	-	-999.9	999.9	°C/°F	R	IR034 (2R)
U		dSP1	Circuit 1: condensation pressure	-	-999.9	999.9	bar/psi	R	IR020 (2R)
U		dSP2	Circuit 2: condensation pressure	-	-999.9	999.9	bar/psi	R	IR028 (2R)
U	x	dSt1	Circuit 1: discharge temperature	-	-999.9	999.9	°C/°F	R	IR012 (2R)
U	x	dSt2	Circuit 2: discharge temperature	-	-999.9	999.9	°C/°F	R	IR016 (2R)
U	x	rUSr	User: return water temperature	-	-999.9	999.9	°C/°F	R	IR054 (2R)
U	x	dUSr	User: delivery water temperature	-	-999.9	999.9	°C/°F	R	IR056 (2R)
U	x	Cnd1	Circuit 1: condensing temperature (or converted value)	-	-999.9	999.9	°C/°F	R	IR024 (2R)
U	x	Cnd2	Circuit 2: condensing temperature (or converted value)	-	-999.9	999.9	°C/°F	R	IR032 (2R)
U		Sprb	Source: outside air temperature	-	-999.9	999.9	°C/°F	R	HR229
U		ScP1	Circuit 1: suction pressure	-	-999.9	999.9	bar/psi	R	IR022 (2R)

User	Display	Code	Description	Def.	Min	Max	UOM	R/W	Modbus
U		ScP2	Circuit 2: suction pressure	-	-999.9	999.9	bar/psi	R	IR030 (2R)
U		Sct1	Circuit 1: suction temperature	-	-999.9	999.9	°C/°F	R	IR014 (2R)
U		Sct2	Circuit 2: suction temperature	-	-999.9	999.9	°C/°F	R	IR018 (2R)
U	x	SetA	Current set point	-	-999.9	999.9	°C/°F	R	IR046 (2R)
U		rSPt	Remote set point	-	-999.9	999.9	°C/°F	R	IR090 (2R)
U	x	SetU	Automatic set point changeover	23	U086	U087	°C/°F	R/W	HR767 (2R)
U		Opn1	ExV circuit 1: position	-	0	9999	%	R	IR050
U		Opn2	ExV circuit 2: position	-	0	9999	%	R	IR053
U	x	SSH1	Circuit 1: suction superheat	-	-999.9	999.9	°C/°F	R	IR048 (2R)
U	x	SSH2	Circuit 2: suction superheat	-	-999.9	999.9	°C/°F	R	IR051 (2R)
S	x	Hd00	BMS: serial address	1	1	245	-	R	HR147
S	x	Hd01	BMS: baud rate 3=9600 - 4=19200 - 5=38400 - 6=57600 - 7=115200	7	3	7	-	R	HR148
S	x	Hd02	BMS: settings 0=8-NONE-1 2=8-EVEN-1 4=8-ODD-1 1=8-NONE-2 3=8-EVEN-2 5=8-ODD-2	0	0	5	-	R	HR149
S		H1C1	Comp. 1 circuit 1: hour counter	-	0	99999	h	R	IR004 (2R)
S		H1C2	Comp. 2 circuit 1: hour counter	-	0	99999	h	R	IR006 (2R)
S		H2C1	Comp. 2 circuit 1: hour counter	-	0	99999	h	R	IR008 (2R)
S		H2C2	Comp. 2 circuit 2: hour counter	-	0	99999	h	R	IR010 (2R)
S		HSP1	Source pump: hour counter	-	0	99999	h	R	IR036 (2R)
S		HuP1	User pump 1: hour counter	-	0	99999	h	R	IR000 (2R)
S		HuP2	User pump 2: hour counter	-	0	99999	h	R	IR002 (2R)
S		HFn1	Fan circuit 1: hour counter	-	0	99999	h	R	IR040 (2R)
S		HFn2	Fan circuit 2: hour counter	-	0	99999	h	R	IR042 (2R)
S	x	rps1	BLDC 1 speed	-	0	999.9	rps	R	IR100 (2R)
S	x	rps2	BLDC 2 speed	-	0	999.9	rps	R	IR181 (2R)
S	x	Mc1	BLDC 1 current	-	0	99.9	A	R	IR102 (2R)
S	x	Mc2	BLDC 2 current	-	0	99.9	A	R	IR183 (2R)
S		MP1	BLDC 1 power	-	0	99.9	kW	R	IR104 (2R)
S		MP2	BLDC 2 power	-	0	99.9	kW	R	IR185 (2R)
S		Drt1	Current speed drive 1 temperature	-	0	999.9	°C/°F	R	IR106 (2R)
S		Drt2	Current speed drive 2 temperature	-	0	999.9	°C/°F	R	IR187 (2R)
S		AlHs1_1	Speed drive 1 alarm log: last	-	0	99	-	R	IR108
S		AlHs2_1	Speed drive 1 alarm log: second-to-last	-	0	99	-	R	IR109
S		AlHs3_1	Speed drive 1 alarm log: third-to-last	-	0	99	-	R	IR110
S		AlHs4_1	Speed drive 1 alarm log: fourth-to-last	-	0	99	-	R	IR111
S		AlHs1_2	Speed drive 2 alarm log: last	-	0	99	-	R	IR189
S		AlHs2_2	Speed drive 2 alarm log: second-to-last	-	0	99	-	R	IR190
S		AlHs3_2	Speed drive 2 alarm log: third-to-last	-	0	99	-	R	IR191
S		AlHs4_2	Speed drive 2 alarm log: fourth-to-last	-	0	99	-	R	IR192

Tab. 6.i

6.11 Settings

User	Display	Code	Description	Def.	Min	Max	UOM	R/W	Modbus
U	x	SEtC	Cooling set point	7.0	U006	U007	°C/°F	R/W	HR307 (2R)
U	x	SEtH	Heating set point	40.0	U008	U009	°C/°F	R/W	HR309 (2R)
U	x	0-1	Unit On-Off from keypad 0=OFF 1=ON	0	0	1	-	R/W	CS54
U	x	ModE	Cooling/heating from keypad 0=Cooling 1=Heating	0	0	1	-	R/W	CS55
-		RES	Reset alarms from BMS 0/1=No/Yes	0	0	1	-	R/W	CS56
S	x	DFr	Force defrost 0=No 1=Circuit 1 2=Circuit 2 3=Circuit 1 and 2	0	0	3	-	R/W	HR78
S	x	ClrH	Reset alarm log 0/1=No/Yes	0	0	1	-	R/W	CS59
S	x	UoM	Unit of measure 0=°C/barg 1=°F/psig	0	0	1	-	R/W	CS47
S	x	rStr	Reset factory parameters	0	0	1	-	R/W	CS45

Tab. 6.j

7. SUPERVISOR TABLE

µChiller provides a database of supervisor variables via Modbus RTU protocol over RS485 (BMS port on the µChiller controller). The BMS port has the following default settings:

- baud rate 115,200;
- data bits 8;
- no parity;
- stop bits 1.

See "Parameter table: BMS port" to set different values. "Index" is the address specified in the Modbus® frame.

7.1 Coil Status

Index	Size	Ref.	Type	Min/Max	R/W	UoM	Description
0	1	U001	BOOL		R/W		U001 - Reset user pump 1 hour counter
1	1	U004	BOOL		R/W		U004 - Reset user pump 2 hour counter
2	1	U010	BOOL		R/W		U010 - Enable set point compensation (0 = Disabled, 1 = Enabled)
3	1	U017	BOOL		R/W		U017 - Enable scheduler (0 = disabled, 1 = enabled)
4	1	U022	BOOL		R/W		U022 - Scheduler type (0 = Switch off, 1 = Change set point)
5	1	U034	BOOL		R/W		U034 - Type of cooling/heating changeover (0 = Keypad, 1 = DIn)
6	1	U036	BOOL		R/W		U036 - Control probe at start-up (0 = Return, 1 = Delivery)
7	1	U038	BOOL		R/W		U038 - Control probe when running (0 = Return, 1 = Delivery)
8	1	U057	BOOL		R/W		U057 - Remote alarm input logic (0 = NC, 1 = NO)
9	1	U058	BOOL		R/W		U058 - Cooling/heating input logic (0 = NO, 1 = NC)
10	1	U059	BOOL		R/W		U059 - Remote unit ON/OFF input logic (0 = NO, 1 = NC)
11	1	U060	BOOL		R/W		U060 - User pump flow input logic (0 = NC, 1 = NO)
12	1	U061	BOOL		R/W		U061 - User pump overload input logic (0 = NC, 1 = NO)
13	1	U062	BOOL		R/W		U062 - 2nd set point input logic (0 = NO, 1 = NC)
14	1	U063	BOOL		R/W		U063 - User pump output logic (0 = NC, 1 = NO)
15	1	U064	BOOL		R/W		U064 - Global alarm relay output logic (0 = NC, 1 = NO)
16	1	U065	BOOL		R/W		U065 - Free cooling valve output logic (0 = NO, 1 = NC)
17	1	U066	BOOL		R/W		U066 - Frost protection heater output logic (0 = NC, 1 = NO)
18	1	U067	BOOL		R/W		U067 - Alarm relay configuration (0 = Control alarms, 1 = All alarms)
19	1	U068	BOOL		R/W		U068 - Enable free cooling (0 = disabled, 1 = enabled)
20	1	E000	BOOL		R/W		E000 - ExV circ. 1 enable manual mode
21	1	E002	BOOL		R/W		E002 - ExV circ. 2 enable manual mode
22	1	Hd06	BOOL		R/W		Hd06 - Enable power supply request from BMS (0 = Disabled, 1 = Enabled)
23	1	C001	BOOL		R/W		C001 - Comp. 1 circ. 1 reset hour counter
24	1	C004	BOOL		R/W		C004 - Comp. 2 circ.1 reset hour counter
25	1	C007	BOOL		R/W		C007 - Comp. 1 circ. 2 reset hour counter
26	1	C010	BOOL		R/W		C010 - Comp. 2 circ. 2 reset hour counter
27	1	C034	BOOL		R/W		C034 - High pressure switch input logic (0 = NC, 1 = NO)
28	1	C035	BOOL		R/W		C035 - Comp. overload input logic (0 = NC, 1 = NO)
29	1	C036	BOOL		R/W		C036 - Comp. output logic (0 = NO, 1 = NC)
30	1	C044	BOOL		R/W		C044 - Enable circuit destabilisation (0 = Disabled, 1 = Enabled)
31	1	S001	BOOL		R/W		S001 - Source pump 1 reset hour counter
33	1	S009	BOOL		R/W		S009 - Source fan 1 circ. 1 reset hour counter
34	1	S013	BOOL		R/W		S013 - Source fan 1 circ. 2 reset hour counter
35	1	S020	BOOL		R/W		S020 - Enable low noise (0 = Disabled, 1 = Enabled)
37	1	S043	BOOL		R/W		S043 - Enable sliding defrost (0 = Disabled, 1 = Enabled)
38	1	S055	BOOL		R/W		S055 - Comp. behaviour after defrosting (0 = Comp. OFF, 1 = Comp. ON)
39	1	S061	BOOL		R/W		S061 - Source fan output logic (0 = NC, 1 = NO)
40	1	S062	BOOL		R/W		S062 - Source pump output logic (0 = NC, 1 = NO)
41	1	S063	BOOL		R/W		S063 - Reversing valve output logic (0 = NC, 1 = NO)
42	1	S064	BOOL		R/W		S064 - Source flow type (0 = Independent, 1 = Common)
44	1	S065	BOOL		R/W		S065 - Source fan type (0 = Inverter, 1 = ON/OFF)
46	1	S068	BOOL		R/W		S068 - Source type (0 = Air, 1 = Water)
47	1	UoM	BOOL		R/W		UM - Unit of measure used for 2-row display and BMS, not Applica (0 = ° C / bar, 1 = ° F / PSI)
48	1	Hc02	BOOL		R/W		Hc02 - Enable analogue channel 4 (0 = Disabled, 1 = Enabled)
49	1	Hc12	BOOL		R/W		Hc12 - Digital output 6 config. (0 = Frost protection, 1 = Source fan / Source pump)
50	1	Hc13	BOOL		R/W		Hc13 - Enable buzzer (0 = Disabled, 1 = Enabled)
52	1	Ha02	BOOL		R/W		Ha02 - Set controller internal clock (0 = No setting, 1 = Set)
53	1	Hd03	BOOL		R/W		Hd03 - Enable NFC (0 = disabled, 1 = enabled)
54	1	UnSt	BOOL		R/W		UnSt - Unit ON/OFF command from keypad (0=OFF 1=ON)
55	1	ModE	BOOL		R/W		ModE - Cool/Heat mode from keypad (0 = Cool, 1 = Heat)
56	1	RES	BOOL		R/W		RES - Reset active alarms from BMS net (0 = NO, 1 = Reset)
59	1	ClrH	BOOL		R/W		ClrH - Delete alarm log (0 = No, 1 = Yes)
63	1	Hd05	BOOL		R/W		Hd05 - Enable unit ON/OFF command from BMS net (0 = Disabled, 1 = Enabled)

Index	Size	Ref.	Type	Min/Max	R/W	UoM	Description
64	1		BOOL		R/W		Unit ON/OFF command from BMS
66	1	P016	BOOL		R/W		P016 - Circ. 1 oil equalisation solenoid valve output logic (0 = NC, 1 = NO)
67	1	P017	BOOL		R/W		P017 - Enable oil equalisation function (0 = OFF, 1 = ON)
68	1	P018	BOOL		R/W		P018 - Enable oil recovery function (0 = OFF, 1 = ON)
69	1	P034	BOOL		R/W		P034 - Enable crankcase heater (0 = OFF, 1 = ON)
80	1	U078	BOOL		R/W		U078 - Enable burst function 4 (0 = Disabled, 1 = Enabled)

Tab. 7.a

7.2 Input Status

Index	Size	Ref.	Type	Min/Max	R/W	UoM	Description
0	1	A01	BOOL		R		Unit - Error in number of retain memory writes
1	1	A02	BOOL		R		Unit: error when writing to retain memory
2	1	A03	BOOL		R		Unit - Remote alarm from digital input
3	1	A04	BOOL		R		Unit - Remote alarm set point out of range
4	1	A05	BOOL		R		Unit - User return water temperature probe broken or disconnected alarm
5	1	A06	BOOL		R		Unit - User delivery water temperature probe broken or disconnected alarm
7	1	A08	BOOL		R		Unit - User pump 1 overload
8	1	A09	BOOL		R		Unit - User pump 2 overload
9	1	A10	BOOL		R		Unit - Flow switch alarm, no flow with user pump 1 on
10	1	A11	BOOL		R		Unit - Flow switch alarm, no flow with user pump 2 on
11	1	A12	BOOL		R		Unit - User pump group alarm
12	1	A13	BOOL		R		Unit - User pump 1 maintenance
13	1	A14	BOOL		R		Unit - User pump 2 maintenance
14	1	A15	BOOL		R		Unit - High chilled water temperature
15	1	A16	BOOL		R		Unit - Source water/air return temperature probe broken or disconnected alarm
16	1	A17	BOOL		R		Unit - Source pump 1 maintenance
17	1	A18	BOOL		R		Unit - Free cooling fault
18	1	A19	BOOL		R		Circuit 1 - Discharge pressure probe broken or disconnected alarm
19	1	A20	BOOL		R		Circuit 1 - Condensing temperature probe broken or disconnected alarm
20	1	A21	BOOL		R		Circuit 1 - Suction pressure probe broken or disconnected alarm
21	1	A22	BOOL		R		Circuit 1 - Evaporation temperature probe broken or disconnected alarm
22	1	A23	BOOL		R		Circuit 1 - Discharge temperature probe broken or disconnected alarm
23	1	A24	BOOL		R		Circuit 1 - Suction temperature probe broken or disconnected alarm
24	1	A25	BOOL		R		Circuit 1 - High pressure alarm from pressure switch
25	1	A26	BOOL		R		Circuit 1 - High pressure alarm from transducer
26	1	A27	BOOL		R		Circuit 1 - Low pressure alarm from transducer
27	1	A28	BOOL		R		Circuit 1 - Evaporation temperature probe frozen alarm
29	1	A30	BOOL		R		Circuit 1 - Compressor 1 overload
30	1	A31	BOOL		R		Circuit 1 - Compressor 2 overload
31	1	A32	BOOL		R		Circuit 1 - Compressor 1 maintenance
32	1	A33	BOOL		R		Circuit 1 - Compressor 2 maintenance
33	1	A34	BOOL		R		Circuit 1 - Source fan 1 maintenance
34	1	A35	BOOL		R		Circuit 1 EVD - Low superheat (SH)
35	1	A36	BOOL		R		Circuit 1 EVD - Low evaporation pressure (LOP)
36	1	A37	BOOL		R		Circuit 1 EVD - Maximum evaporation pressure (MOP)
37	1	A38	BOOL		R		Circuit 1 EVD - Valve motor error
38	1	A39	BOOL		R		Circuit 1 EVD - Emergency closing
39	1	A40	BOOL		R		Circuit 1 EVD - Incomplete valve closure
40	1	A41	BOOL		R		Circuit 1 EVD - Offline
41	1	A42	BOOL		R		Circuit 1 envelope - General alarm + zone alarm
42	1	A43	BOOL		R		Circuit 1 BLDC - Pressure difference greater than allowed at start-up
43	1	A44	BOOL		R		Circuit 1 BLDC - Start-up failed
44	1	A45	BOOL		R		Circuit 1 BLDC - Low differential pressure
45	1	A46	BOOL		R		Circuit 1 BLDC - High gas discharge temperature
46	1	A47	BOOL		R		Inverter circuit 1 - Offline
47	1	A48	BOOL		R		Inverter circuit 1 - General alarm + error code
48	1	A49	BOOL		R		Unit - Circuit 2 board offline
49	1	A50	BOOL		R		Unit - Error in number of retain memory writes, circuit 2 board
50	1	A51	BOOL		R		Unit - Error when writing to retain memory, circuit 2 board
51	1	A52	BOOL		R		Circuit 2 - Discharge pressure probe broken or disconnected alarm
52	1	A53	BOOL		R		Circuit 2 - Condensing temperature probe broken or disconnected alarm
53	1	A54	BOOL		R		Circuit 2 - Suction pressure probe broken or disconnected alarm
54	1	A55	BOOL		R		Circuit 2 - Evaporation temperature probe broken or disconnected alarm
55	1	A56	BOOL		R		Circuit 2 - Discharge temperature probe broken or disconnected alarm
56	1	A57	BOOL		R		Circuit 2 - Suction temperature probe broken or disconnected alarm
57	1	A58	BOOL		R		Circuit 2 - High pressure alarm from pressure switch
58	1	A59	BOOL		R		Circuit 2 - High pressure alarm from transducer
59	1	A60	BOOL		R		Circuit 2 - Low pressure alarm from transducer
60	1	A61	BOOL		R		Circuit 2 - Evaporation temperature probe frozen alarm
62	1	A63	BOOL		R		Circuit 2 - Compressor 1 overload
63	1	A64	BOOL		R		Circuit 2 - Compressor 2 overload
64	1	A65	BOOL		R		Circuit 2 - Compressor 1 maintenance

Index	Size	Ref.	Type	Min/Max	R/W	UoM	Description
65	1	A66	BOOL		R		Circuit 2 - Compressor 2 maintenance
66	1	A67	BOOL		R		Circuit 2 - Source fan 1 maintenance
67	1	A68	BOOL		R		Circuit 2 EVD - Low superheat (SH)
68	1	A69	BOOL		R		Circuit 2 EVD - Low evaporation pressure (LOP)
69	1	A70	BOOL		R		Circuit 2 EVD - Maximum evaporation pressure (MOP)
70	1	A71	BOOL		R		Circuit 2 EVD - Valve motor error
71	1	A72	BOOL		R		Circuit 2 EVD - Emergency closing
72	1	A73	BOOL		R		Circuit 2 EVD - Incomplete valve closure
73	1	A74	BOOL		R		Circuit 2 EVD - Offline
74	1	A75	BOOL		R		Circuit 2 envelope - General alarm + zone alarm
75	1	A76	BOOL		R		Circuit 2 BLDC - Pressure difference greater than allowed at start-up
76	1	A77	BOOL		R		Circuit 2 BLDC - Start-up failed
77	1	A78	BOOL		R		Circuit 2 BLDC - Low differential pressure
78	1	A79	BOOL		R		Circuit 2 BLDC - High gas discharge temperature
79	1	A80	BOOL		R		Inverter circuit 2 - Offline
80	1	A81	BOOL		R		Inverter circuit 2 - General alarm + error code
81	1		BOOL		R		PrevAFreeze_C1 - Frost protection prevention request active in circuit 1
82	1		BOOL		R		PrevHP_C1 - High pressure prevention request active in circuit 1
83	1		BOOL		R		PrevAFreeze_C2 - Frost protection prevention request active in circuit 2
84	1		BOOL		R		PrevHP_C2 - High pressure prevention request active in circuit 2
102	1		BOOL		R		Comp1Circ1_On - Comp. 1 circ. 1 status (0=OFF, 1=ON)
103	1		BOOL		R		Comp2Circ1_On - Comp. 2 circ. 1 status (0=OFF, 1=ON)
104	1		BOOL		R		Comp1Circ2_On - Comp. 1 circ. 2 status (0=OFF, 1=ON)
105	1		BOOL		R		Comp2Circ2_On - Comp. 2 circ. 2 status (0=OFF, 1=ON)
106	1		BOOL		R		RelayAlrm - General alarm from relay
107	1		BOOL		R		CoolHeat - Unit in heating mode (0 = Cooling, 1 = Heating)
108	1		BOOL		R		FC_Status - Free cooling valve status (0=OFF, 1=ON)
109	1		BOOL		R		Frost protection heater status
110	1		BOOL		R		Unit scheduler status
119	1	A87	BOOL		R		EVD - Incompatible HW alarm
120	1		BOOL		R		SrcFanCirc1_On - Source fan circ. 1 status (0 = OFF, 1 = ON)
121	1		BOOL		R		SrcPmp1_On - Source pump 1 status (0 = OFF, 1 = ON)
122	1		BOOL		R		UsrPmp1_On - User pump 1 status
123	1		BOOL		R		RevVlv_Circ1 - Reversing valve for circ. 1 (0 = Cooling, 1 = Heating)
124	1		BOOL		R		Oil equalisation valve circuit 1 status
125	1		BOOL		R		SrcFanCirc2_On - Source fan circuit 2 status (0 = OFF, 1 = ON)
127	1		BOOL		R		UsrPmp2_On - User pump 2 status
128	1		BOOL		R		RevVlv_Circ2 - Reversing valve for circ. 2 (0 = Cooling, 1 = Heating)
129	1		BOOL		R		Oil equalisation valve circuit 2 status
131	1		BOOL		R		Defrost in progress in circuit 1
132	1		BOOL		R		Defrost in progress in circuit 2
134	1		BOOL		R		Unit status
143	1		BOOL		R		Comp. 1 circuit 1 overridden by oil migration management
144	1		BOOL		R		Comp. 2 circuit 1 overridden by oil migration management
145	1		BOOL		R		Comp. 2 circuit 1 overridden by oil migration management
146	1		BOOL		R		Comp. 2 circuit 2 overridden by oil migration management
148	1		BOOL		R		UsrFlw_Absent - User pump flow absent (0 = Flow OK, 1 = Flow absent)

Tab. 7.b

7.3 Holding Register

Index	Size	Ref.	Type	Min/Max	R/W	UoM	Description
2	1	U000	INT	0 to 999	R/W	h	U000 - User 1 pump maintenance hour threshold (x100)
3	1	U002	INT	0..2	R/W		U002 - User pump 1 / fan manual mode (0 = AUTO, 1 = OFF, 2 = ON)
4	1	U003	INT	0 to 999	R/W	h	U003 - User 2 pump maintenance hour threshold (x100)
5	1	U005	INT	0..2	R/W		U005 - User pump 2 manual mode (0 = AUTO, 1 = OFF, 2 = ON)
7	2	U006	REAL	-99.9..999.9	R/W	°C/°F	U006 - Cooling set point lower limit
9	2	U007	REAL	-99.9..999.9	R/W	°C/°F	U007 - Cooling set point upper limit
11	2	U008	REAL	0..999.9	R/W	°C/°F	U008 - Heating set point lower limit
13	2	U009	REAL	0..999.9	R/W	°C/°F	U009 - Heating set point upper limit
15	2	U011	REAL		R/W	°C/°F	U011 - Initial temp. for set point compensation in cooling
17	2	U012	REAL	-99.9..99.9	R/W	°C/°F	U012 - Final temp. for set point compensation in cooling
19	2	U013	REAL	-99.9..99.9	R/W	K/R	U013 - Maximum set point compensation in cooling
21	2	U014	REAL	-999.9..999.9	R/W	°C/°F	U014 - Initial temp. for set point compensation in heating
23	2	U015	REAL	-99.9..99.9	R/W	°C/°F	U015 - Outside temp. diff. for set point compensation in heating
25	2	U016	REAL	-99.9..99.9	R/W	K/R	U016 - Maximum set point compensation in heating
27	1	U018	INT	0..23	R/W	h	Time band hours
28	1	U019	INT	0..59	R/W	min	Time band minutes
29	1	U020	INT	0..23	R/W	h	Time band hours
30	1	U021	INT	0..59	R/W	min	Time band minutes
31	2	U023	REAL	U006..U007	R/W	°C/°F	U023 - 2nd cooling set point
33	2	U024	REAL	U008..U009	R/W	°C/°F	U024 - 2nd heating set point

Index	Size	Ref.	Type	Min/Max	R/W	UoM	Description
35	1	U025	INT	0..2	R/W		U025 - Analogue set point input type (0 = 0-5V, 1 = 0-10V, 2 = 4-20mA)
37	2	U026	REAL	-99.9..99.9	R/W	°C/°F	U026 - Minimum remote set point value
39	2	U027	REAL	-99.9..99.9	R/W	°C/°F	U027 - Max remote set point value
41	1	E023	INT	0..23	R/W	h	Time band hours
42	1	S024	INT	0..59	R/W	min	Time band minutes
43	2	U028	REAL	-99.9..99.9	R/W	K/R	U028 - Remote set point offset
48	1	E046	INT	1..24	R/W		E046 - ExV valve type for EVD EVO (1 = CAREL EXV, ...)
49	2	U031	REAL	0..99.9	R/W	K/R	U031 - High water temp. alarm: offset
51	1	U032	INT	0..99	R/W	min	U032 - High water temp. alarm: delay at start-up
52	1	U033	INT	0 to 999	R/W	s	U033 - High water temp. alarm: delay when running
53	1	U035	INT	0 to 999	R/W	min	U035 - Changeover delay time
54	1	U037	INT	0 to 999	R/W	s	U037 - Delay time between Startup PID and Run PID
55	2	U039	REAL	0..999.9	R/W		U039 - Startup PID Kp
57	1	U040	INT	0 to 999	R/W	s	U040 - PID at start-up Ti
58	1	U041	INT	0..99	R/W	s	U041 - Startup PID Td
59	2	U042	REAL	0..999.9	R/W		U042 - Kp for PID when running
61	1	U043	INT	0 to 999	R/W	s	U043 - Ti for PID when running
62	1	U044	INT	0..99	R/W	s	U044 - Td for PID when running
63	1	U045	INT	0 to 999	R/W	s	U045 - User pump flow alarm delay at start-up
64	1	U046	INT	0..99	R/W	s	U046 - User pump flow alarm delay when running
65	1	U047	INT	0 to 999	R/W	s	U047 - Comp. ON delay from user pump ON
66	1	U048	INT	0 to 999	R/W	s	U048 - User pump OFF delay from comp. OFF
67	1	U049	INT	0 to 999	R/W	h	U049 - User pump rotation time
68	2	U050	REAL	-999.9..999.9	R/W	°C/°F	U050 - User frost protection alarm threshold
70	2	U051	REAL	0..999.9	R/W	K/R	U051 - User frost protection alarm differential
72	1	U052	INT	0 to 999	R/W	s	U052 - User frost protection alarm delay at 1K below the threshold
73	2	U053	REAL	-999.9..999.9	R/W	°C/°F	U053 - Frost protection set point (with unit OFF)
75	2	U054	REAL	0..99.9	R/W	K/R	U054 - Frost protection differential (with unit OFF)
78	1	DFr	INT	0..3	R/W		DFr - Force manual defrost (0 = None, 1 = Force defrost circuit 1, 2 = Force defrost circuit 2, 3 = Force defrost on all circuits)
79	2	U055	REAL	-99.9..99.9	R/W	K/R	U055 - User return water temp. probe offset
83	2	U056	REAL	-99.9..99.9	R/W	K/R	U056 - User delivery water temp. probe offset
85	2	U069	REAL	0..99.9	R/W	K/R	U069 - Temp. differential to activate free cooling
87	2	U070	REAL	0..99.9	R/W	K/R	U070 - Free cooling ON/OFF hysteresis
89	2	U071	REAL	0..99.9	R/W	K/R	U071 - Design free cooling temp. differential (to reach unit rated capacity)
91	2	U072	REAL	-999.9..999.9	R/W	°C/°F	U072 - Free cooling limit threshold (used to close the FC valve: because FC supplies water at very low temp.)
93	2	U073	REAL	0..99.9	R/W	K/R	U073 - Free cooling limit differential
95	1	U074	INT	0..2	R/W		U074 - Free cooling type (0 = Air, 1 = Remote air coil, 2 = Water)
96	1	U075	INT	0..2	R/W		U075 - Frost protection type (0 = Heater, 1 = Pump, 2 = Heater/pump)
97	1	U076	INT	1..2	R/W		U076 - Number of user pumps
98	1	U077	INT	0..2	R/W		U077 - Type of unit (0 = CH, 1 = HP, 2 = CH/HP)
99	1	E001	INT	0..65535	R/W	Steps	E001 - ExV: Steps in manual mode circ. 1
100	1	E003	INT	0..65535	R/W	Steps	E003 - ExV: Steps in manual mode circ. 2
101	2	E004	REAL	-40..180	R/W	K/R	E004 - ExV: SH set point in cooling
103	2	E005	REAL	0..800	R/W		E005 - ExV: SH control Kp in cooling
105	2	E006	REAL	0..1000	R/W	s	E006 - ExV: SH control Ti in cooling
107	2	E007	REAL	0..800	R/W	s	E007 - ExV: SH control Td in cooling
109	2	E008	REAL	-40..180	R/W	K/R	E008 - ExV: SH set point in heating
111	2	E009	REAL	0..800	R/W		E009 - ExV: SH control Kp in heating
113	2	E010	REAL	0..1000	R/W	s	E010 - ExV: SH control Ti in heating
115	2	E011	REAL	0..800	R/W	s	E011 - ExV: SH control Td in heating
117	2	E012	REAL	-40..180	R/W	K/R	E012 - ExV: low SH in cooling: threshold
119	2	E013	REAL	0..800	R/W	s	E013 - ExV: low SH in cooling: Ti
121	2	E014	REAL	-40..180	R/W	K/R	E014 - ExV: low SH in heating: threshold
123	2	E015	REAL	0..800	R/W	s	E015 - ExV: low SH in heating: Ti
125	2	E016	REAL	-60..200	R/W	°C/°F	E016 - ExV: LOP control in cooling: threshold
127	2	E017	REAL	0..800	R/W	s	E017 - ExV: LOP control in cooling: Ti
129	2	E018	REAL	-60..200	R/W	°C/°F	E018 - ExV: LOP control in heating: threshold
131	2	E019	REAL	0..800	R/W	s	E019 - ExV: LOP control in heating: Ti
133	2	E020	REAL	-60..200	R/W	°C/°F	E020 - ExV: MOP control in cooling: threshold
135	2	E021	REAL	0..800	R/W	s	E021 - ExV: MOP control in cooling: Ti
137	2	E022	REAL	-60..200	R/W	°C/°F	E022 - ExV: MOP control in heating: threshold
139	2	E023	REAL	0..800	R/W	s	E023 - ExV: MOP control in heating: Ti
141	1	E024	INT	0..18000	R/W	s	E024 - ExV: low SH alarm delay
142	1	E025	INT	0..18000	R/W	s	E025 - ExV: LOP alarm delay time
143	1	E026	INT	0..18000	R/W	s	E026 - ExV: MOP alarm delay time
144	1	E032	INT	0..100	R/W	%	E032 - ExV: % valve opening at start-up (EVAP / EEV capacity ratio) in cooling
145	1	E033	INT	0..100	R/W	%	E033 - ExV: % valve opening at start-up (EVAP / EEV capacity ratio) in heating
146	1	E034	INT	0..18000	R/W	s	E034 - ExV: control delay after pre-positioning
147	1	Hd00	INT	1..247	R/W		Hd00 - BMS port serial address
148	1	Hd01	INT	3..7	R/W		Hd01 - BMS port baud rate (3 = 9600, 4 = 19200, 5 = 38400, 6 = 57600, 7 = 115200)
149	1	Hd02	INT	0..5	R/W		Hd02 - BMS network port settings (0 = 8- NONE- 1, 1 = 8- NONE- 2, 2 = 8- EVEN- 1, 3 = 8-EVEN-2, 4 = 8-ODD-1, 5 = 8-ODD-2)

Index	Size	Ref.	Type	Min/Max	R/W	UoM	Description
153	1	C000	INT	0 to 999	R/W	h	C000 - Maintenance hours threshold comp.1 circ.1 (x100)
154	1	C002	INT	0..2	R/W		C002 - Comp. 1 circ. 1 manual mode (0 = AUTO, 1 = OFF, 2 = ON)
155	1	C003	INT	0 to 999	R/W	h	C003 - Maintenance hours threshold comp. 2 circ. 1 (x100)
156	1	C005	INT	0..2	R/W		C005 - Comp. 2 circ. 1 manual mode (0 = AUTO, 1 = OFF, 2 = ON)
157	1	C006	INT	0 to 999	R/W	h	C006 - Maintenance hours comp. 1 circ. 2 (x100)
158	1	C008	INT	0..2	R/W		C008 - Comp. 1 circ. 2 manual mode (0 = AUTO, 1 = OFF, 2 = ON)
159	1	C009	INT	0 to 999	R/W	h	C009 - Maintenance hours threshold comp. 2 circ. 2 (x100)
160	1	C011	INT	0..2	R/W		C011 - Comp. 2 circ. 2 manual mode (0 = AUTO, 1 = OFF, 2 = ON)
162	1	C012	INT	30 to 999	R/W	s	C012 - Minimum compressor ON time
163	1	C013	INT	30 to 999	R/W	s	C013 - Minimum compressor OFF time
164	1	C014	INT	300 to 999	R/W	s	C014 - Minimum time between same compressor ON
165	1	C015	INT	10 to 999	R/W	s	C015 - Compressor load up time
166	1	C016	INT	5 to 999	R/W	s	C016 - Compressor load down time
167	1	S021	INT	0..23	R/W	h	Time band hours
168	1	C020	INT	5 to 999	R/W	min	C020 - Max circuit destabilisation time with one or more comp. OFF
169	1	C021	INT	0..1	R/W		C021 - Circuit capacity distribution (0 = balanced, 1 = grouped)
170	2	C022	REAL	-99.9..99.9	R/W	K/R	C022 - Discharge temp. probe offset circ. 1
172	2	C023	REAL	-99.9..99.9	R/W	K/R	C023 - Suction temp. probe offset circ. 1
174	2	C024	REAL	-99.9..99.9	R/W	K/R	C024 - Discharge temp. probe offset circ. 2
176	2	C025	REAL	-99.9..99.9	R/W	K/R	C025 - Suction temp. probe offset circ. 2
178	2	C026	REAL	-99.9..99.9	R/W	bar/psi	C026 - Discharge pressure probe offset circ. 1
180	2	C027	REAL	-99.9..99.9	R/W	bar/psi	C027 - Suction pressure probe offset circ. 1
182	2	C028	REAL	-99.9..99.9	R/W	K/R	C028 - Condensing temp. probe offset circ. 1
184	2	C029	REAL	-99.9..99.9	R/W	K/R	C029 - Evaporation temp. probe offset circ. 1
186	2	C030	REAL	-99.9..99.9	R/W	bar/psi	C030 - Discharge pressure probe offset circ. 2
188	2	C031	REAL	-99.9..99.9	R/W	bar/psi	C031 - Suction pressure probe offset circ. 2
190	2	C032	REAL	-99.9..99.9	R/W	K/R	C032 - Cond. temp. probe offset circ. 2
192	2	C033	REAL	-99.9..99.9	R/W	K/R	C033 - Evaporation temp. probe offset circ. 2
194	1	C037	INT	0..1	R/W		C037 - Suction pressure: probe type (0 = 0-5V, 1 = 4-20mA)
195	2	C038	REAL	-1.0..99.9	R/W	bar/psi	C038 - Suction pressure: minimum probe value
197	2	C039	REAL	0.0..99.9	R/W	bar/psi	C039 - Suction pressure: max probe value
199	1	C040	INT	0..1	R/W		C040 - Discharge pressure: probe type (0 = 0-5V, 1 = 4-20mA)
200	2	C041	REAL	-1.0..99.9	R/W	bar/psi	C041 - Discharge pressure: minimum probe value
202	2	C042	REAL	0.0..99.9	R/W	bar/psi	C042 - Discharge pressure: max probe value
204	1	C043	INT	0..1	R/W		C043 - Discharge temp.: probe type (0 = NTC, 1 = NTC-HT)
206	1	C046	INT	1..2	R/W		C046 - Number of circuits on the unit
207	1	C047	INT	0..1/3	R/W		C047 - Type of compressors used (0 = 1 ON / OFF, 1 = 2 ON / OFF, 2 = BLDC, 3 = BLDC + ON / OFF)
208	1	C048	INT	1..2	R/W		C048 - Compressor rotation type (1 = FIFO, 2 = TIME)
209	1	S000	INT	0 to 999	R/W	h	S000 - Source pump 1 maintenance hour threshold (x100)
210	1	S002	INT	0..2	R/W		S002 - Source pump 1 manual mode (0 = AUTO, 1 = OFF, 2 = ON)
212	1	S022	INT	0..59	R/W	min	Time band minutes
214	1	S008	INT	0 to 999	R/W	h	S008 - Source fan 1 circ. 1 maintenance hours threshold (x100)
215	1	S010	INT	0..2	R/W		S010 - ON/OFF source fan circ. 1 manual mode (0 = AUTO, 1 = OFF, 2 = ON)
216	1	S011	INT	0..101	R/W	%	S011 - Inverter source fan circ. 1 manual mode (0 = AUTO, 1 = 0%, 2 = 1%, .. 101 = 100%)
217	1	S012	INT	0 to 999	R/W	h	S012 - Source fan 1 circ. 2 maintenance hours threshold (x100)
218	1	S014	INT	0..2	R/W		S014 - ON/OFF source fan circ. 2 manual mode (0 = AUTO, 1 = OFF, 2 = ON)
219	1	S015	INT	0..101	R/W	%	S015 - Inverter source fan circ. 2 manual mode (0 = AUTO, 1 = 0%, 2 = 1%, .. 101 = 100%)
220	2	S016	REAL	-999.9..999.9	R/W	°C/°F	S016 - Source fan temp. threshold for cold climates
222	2	S017	REAL	0..100	R/W	%	S017 - Minimum source fan speed for cold climates
224	2	S018	REAL	0..100	R/W	%	S018 - Source fan acceleration speed for cold climates
226	1	S019	INT	0..300	R/W	s	S019 - Source fan acceleration time for cold climates
227	2		REAL		R/W	%	FC_PrwReq - Free cooling control ramp
229	2	Sprb	REAL		R	°C/°F	SPrb - Source outside air temperature;
231	2	S025	REAL	0..999.9	R/W	°C/°F	S025 - Source fan low noise set point in cooling
233	1	S026	INT	0 to 999	R/W	s	S026 - Comp. ON delay from source pump ON
234	1	S027	INT	0 to 999	R/W	s	S027 - Source pump OFF delay from comp. OFF
235	2	S028	REAL	-999.9..999.9	R/W	°C/°F	S028 - Source fan set point in cooling
237	2	S029	REAL	0..99.9	R/W	°C/°F	S029 - Source fan set point in heating
241	2	S031	REAL	0..999.9	R/W	°C/°F	S031 - Source fan set point in cooling at start-up
243	1	S032	INT	0 to 999	R/W	s	S032 - Source fan start delay in cooling
246	2	S034	REAL	0..99.9	R/W	K/R	S034 - Source fan differential in cooling
248	2	S035	REAL	0..99.9	R/W	K/R	S035 - Source fan differential in heating
250	2	S036	REAL	0..100	R/W	%	S036 - Source fan inverter min speed
252	2	S037	REAL	0..100	R/W	%	S037 - Source fan inverter max speed
254	2	S039	REAL	-99.9..99.9	R/W	°C/°F	S039 - Start defrost threshold
256	2	S040	REAL	S039..99.9	R/W	°C/°F	S040 - Reset start defrost threshold
258	1	S041	INT	0 to 999	R/W	min	S041 - Start defrost delay
259	2	S042	REAL	-999.9..999.9	R/W	°C/°F	S042 - End defrost threshold
261	1	S044	INT	0 to 999	R/W	s	S044 - Start defrost delay before 4-way valve is activated
262	1	S045	INT	0 to 999	R/W	s	S045 - End defrost delay after 4-way valve has been activated
263	1	S046	INT	0..99	R/W	min	S046 - Minimum defrost duration
264	1	S047	INT	0..99	R/W	min	S047 - Max defrost duration

Index	Size	Ref.	Type	Min/Max	R/W	UoM	Description
265	1	S048	INT	0 to 999	R/W	s	S048 - Dripping duration
266	1	S049	INT	0 to 999	R/W	s	S049 - Post-dripping duration
267	1	S050	INT	0 to 999	R/W	min	S050 - Delay between defrosts
272	1	S053	INT	0..2	R/W		S053 - Defrost synchronisation type (0 = Independent, 1 = Separate, 2 = Simultaneous)
274	2	S054	REAL	0..999.9	R/W	bar/psi	S054 - Pressure differential to reverse 4-way valve
278	1	S056	INT	20 to 999	R/W	s	S056 - Smart start function duration
279	2	S057	REAL	-999.9..999.9	R/W	°C/°F	S057 - Source frost protection alarm threshold
281	2	S058	REAL	0 to 999	R/W	K/R	S058 - Source frost protection alarm differential
283	1	S059	INT	0 to 999	R/W	s	S059 - Source frost protection alarm delay at 1K below the threshold
284	2	S060	REAL	-99.9..99.9	R/W	K/R	S060 - Source outside air temperature offset
286	1	Hc00	INT	0..3/4	R/W		Hc00 - Analogue input 3 configuration (0 = not used, 1 = source temp., 2 = discharge temp., 3 = suction temp., 4 = source delivery water temp.)
287	1	Hc01	INT	0..1	R/W		Hc01 - Analogue input 4 and 5 configuration (0 = pressure, 1 = temp.)
288	1	Hc03	INT	0..2	R/W		Hc03 - Analogue input 6 configuration (0 = not used, 1 = remote set point, 2 = source temp.)
289	1	Hc04	INT	0..1	R/W		Hc04 - Analogue input 7 configuration (0 = not used, 1 = suction temp.)
290	1	Hc05	INT	0..1	R/W		Hc05 - Analogue input 6 configuration, circuit 2 board (0 = not used, 1 = remote set point)
291	1	Hc06	INT	0..6	R/W		Hc06 - Digital input 4 configuration (0 = Not used, 1 = Comp. 2 circ. 1 overload, 2 = Remote ON/OFF, 3 = Cool/Heat, 4 = 2nd set point, 5 = Remote alarm, 6 = User pump 1 overload)
292	1	Hc07	INT	0..6	R/W		Hc07 - Digital input 5 configuration (0 = Not used, 1 = Comp. 2 circ. 1 overload, 2 = Remote ON/OFF, 3 = Cool/Heat, 4 = 2nd set point, 5 = Remote alarm, 6 = User pump 1 overload)
293	1	Hc08	INT	0..6	R/W		Hc08 - Digital input 6 configuration (0 = Not used, 1 = Comp. 2 circ. 1 overload, 2 = Remote ON/OFF, 3 = Cool/Heat, 4 = 2nd set point, 5 = Remote alarm, 6 = User pump 1 overload)
294	1	Hc09	INT	0..5	R/W		Hc09 - Digital input 4 configuration, circuit 2 board (0 = Not used, 1 = Comp. 2 circ. 2 overload, 2 = Remote ON/OFF, 3 = Cool/Heat, 4 = 2nd set point, 5 = Remote alarm, 6 = User pump 1 overload)
295	1	Hc10	INT	0..5	R/W		Hc10 - Digital input 5 configuration, circuit 2 board (0 = Not used, 1 = Comp. 2 circ. 2 overload, 2 = Remote ON/OFF, 3 = Cool/Heat, 4 = 2nd set point, 5 = Remote alarm, 6 = User pump 1 overload)
296	1	Hc11	INT	0..5	R/W		Hc11 - Digital input 6 configuration, circuit 2 board (0 = Not used, 1 = Comp. 2 circ. 2 overload, 2 = Remote ON/OFF, 3 = Cool/Heat, 4 = 2nd set point, 5 = Remote alarm, 6 = User pump 1 overload)
297	1	Hc14	USINT	0..ID_CfgLim- Max	R/W		Hc14 - Digital input 1 configuration (0 = Not used, 1 = User flow switch, 2 = Comp. 1 circuit 1 overload, 3 = Comp. 2 circuit 1 overload, 4 = Remote ON/OFF, 5 = Cool/Heat, 6 = 2nd set point, 7 = Remote alarm, 8 = User pump 1 overload, 9 = Low pressure switch, 10 = User pump 2 overload, 11 = Remote control 1, 12 = Remote control 2)
298	1	Hc15	USINT	0..ID_CfgLim- Max	R/W		Hc15 - Digital input 2 configuration (0 = Not used, 1 = User flow switch, 2 = Comp. 1 circuit 1 overload, 3 = Comp. 2 circuit 1 overload, 4 = Remote ON/OFF, 5 = Cool/Heat, 6 = 2nd set point, 7 = Remote alarm, 8 = User pump 1 overload, 9 = Low pressure switch, 10 = User pump 2 overload, 11 = Remote control 1, 12 = Remote control 2)
299	1	Hc16	USINT	0..ID_CfgLim- Max_Slv	R/W		Hc16 - Digital input 1 configuration, circuit 2 board (0 = Not used, 1 = User flow switch, 2 = Comp. 1 circuit 2 overload, 3 = Comp. 2 circuit 2 overload, 4 = Remote ON/OFF, 5 = Cool/Heat, 6 = 2nd set point, 7 = Remote alarm, 8 = User pump 1 overload, 9 = Low pressure switch, 10 = User pump 2 overload, 11 = Remote control 3, 12 = Remote control 4)
300	1	Hc17	USINT	0..ID_CfgLim- Max_Slv	R/W		Hc17 - Digital input configuration, circuit 2 board (0 = Not used, 1 = User flow switch, 2 = Comp. 1 circuit 2 overload, 3 = Comp. 2 circuit 2 overload, 4 = Remote ON/OFF, 5 = Cool/Heat, 6 = 2nd set point, 7 = Remote alarm, 8 = User pump 1 overload, 9 = Low pressure switch, 10 = User pump 2 overload, 11 = Remote control 3, 12 = Remote control 4)
301	1	Al_CfgLim- Max_ Grp2	USINT	---	R/W		Maximum limit probe group 2
307	2	SEtC	REAL	U006..U007	R/W	°C/°F	SEtC - Cooling set point
309	2	SEtH	REAL	U008..U009	R/W	°C/°F	SEtH - Heating set point
324	2	C017	REAL	0..999.9	R/W	°C/°F	C017 - Maximum high pressure threshold (HP)
326	2	C018	REAL	-99.9..99.9	R/W	bar/psi	C018 - Min low pressure threshold (LP)
328	1	E047	INT	0..2	R/W		E047 - Type of ExV driver (0 = Disabled, 1 = EVD embedded, 2 = EVD EVO)
335	2	P000	REAL	-999.9..999.9	R/W	°C/°F	P000 - Min evaporation temp. limit for custom envelope
337	2	P001	REAL	-999.9..999.9	R/W	°C/°F	P001 - Max condensing temp. limit for custom envelope
339	1	P002	INT	0 to 999	R/W	s	P002 - Min. prevent duration
340	1	P003	INT	0 to 999	R/W	s	P003 - Out of envelope alarm delay time
341	1	P004	INT	0 to 999	R/W	s	P004 - Low pressure differential alarm delay
342	2	P005	REAL	0..999.9	R/W	rps	P005 - Min BLDC speed threshold for circuit destabilisation
344	2	P006	REAL	0..100	R/W	%	P006 - Oil recovery min request for activation
346	2	P007	REAL	0..999.9	R/W	rps	P007 - Oil recovery min comp. speed for activation
348	1	P008	INT	0 to 999	R/W	min	P008 - Oil recovery time before activation in which the compressor can operate at minimum speed
349	1	P009	INT	0 to 999	R/W	min	P009 - Oil recovery duration to override comp. speed
350	2	P010	REAL	0..999.9	R/W	rps	P010 - Oil recovery comp. override speed

Index	Size	Ref.	Type	Min/Max	R/W	UoM	Description
352	1	P011	INT	0 to 999	R/W	s	P011- Oil equalisation start-up time for solenoid valve at comp. start
353	1	P012	INT	0 to 999	R/W	s	P012 - Oil equalisation solenoid valve opening time
354	1	P013	INT	0 to 999	R/W	min	P013 - Oil equalisation solenoid valve min OFF time
355	1	P014	INT	0 to 999	R/W	min	P014 - Oil equalisation solenoid valve max OFF time
356	1	P015	INT	0 to 999	R/W	min	P015 - Max oil equalisation time for management
357	1	P019	INT	0..101	R/W	%	P019 - Compressor 1 circuit 1 manual mode (0 = AUTO, 1 = 0%, ... 101 = 100%)
358	1	P020	INT	0..101	R/W	%	P020 - Compressor 1 circuit 2 manual mode (0 = AUTO, 1 = 0%, ... 101 = 100%)
359	2	P021	REAL		R/W	kPa	P021 - Maximum delta P allowed for start-up
361	1	P022	INT		R/W	s	P022 - Maximum EVD propulsion time to equalise pressure
362	1	P023	INT		R/W	%	P023 - EVD pre-opening for pre-start to equalise the pressure
363	2	P024	REAL		R/W	rps	P024 - Start-up speed
365	2	P025	REAL		R/W	rps	P025 - Maximum custom speed (rps)
367	2	P026	REAL		R/W	rps	P026 - Minimum custom speed (rps)
369	2	P027	REAL	0..100	R/W	%	P027 - BLDC speed request threshold % for call
371	2	P028	REAL	20..100	R/W	%	P028 - BLDC speed threshold to call fixed speed compressor
373	2	P029	REAL	20..100	R/W	%	P029 - BLDC speed threshold to switch off the fixed speed compressor
375	2	P030	REAL		R/W		P030 - Skip frequency: set 1 [010]
377	2	P031	REAL		R/W		P031 - Skip frequency: band 1 [011]
379	1	P032	INT		R/W		P032 - Enable motor overtemperature alarm (PTC) (0 = OFF, 1 = ON) [027]
380	1	P033	INT		R/W		P033 - Motor overtemperature alarm delay [028]
382	2	S051	REAL	0..999.9	R/W	rps	S051 - BLDC defrost speed
384	2	S052	REAL	0..999.9	R/W	rps	S052 - BLDC cycle reversal speed in defrost
703	1		INT		R/W		MotTyp - Carel BLDC database ID
704	1		INT		R/W		Poles - Number of motor poles
709	1	U079	INT	1..15	R/W	min	U079 - Burst function user pump ON time
710	1	U080	INT	3..99	R/W	min	U080 - Burst function user pump OFF time
732	2	S070	REAL	-99.9..99.9	R/W	K/R	S070 - Cond. 1 frost protection temp. probe offset (S3)
734	2	S071	REAL	99.9..99.9	R/W	K/R	S071 - Cond. 2 frost protection temp. probe offset (S3 exp.)
736	2	S069	REAL	0..99.9	R/W	°C/°F	S069 - Fan-Defrost function temperature set point (0 = Function disabled)

Tab. 7.c

7.4 Input Register

Index	Size	Ref.	Type	Min/Max	R/W	UoM	Description
0	2	HuP1	INT		R	h	HuP1 - User pump 1 operating hours
2	2	HuP2	INT		R	h	HuP2 - User pump 2 operating hours
4	2	H1C1	INT		R	h	H1C1 - Comp. 1 circ. 1 operating hours
6	2	H1C2	INT		R	h	H1C2 - Comp. 2 circ. 1 operating hours
8	2	H2C1	INT		R	h	H2C1 - Comp. 1 circ. 2 operating hours
10	2	H2C2	INT		R	h	H2C2 - Comp. 2 circ. 2 operating hours
12	2	dSt1	REAL		R	°C/°F	dSt1 - Discharge temp. probe circ. 1
14	2	Sct1	REAL		R	°C/°F	Sct1 - Suction temp. probe circ. 1
16	2	dSt2	REAL		R	°C/°F	dSt2 - Discharge temp. probe circ. 2
18	2	Sct2	REAL		R	°C/°F	Sct2 - Suction temp. probe circ. 2
20	2	dSP1	REAL		R	bar/psi	dSP1 - Discharge pressure probe circ. 1
22	2	ScP1	REAL		R	bar/psi	ScP1 - Suction pressure probe circ. 1
24	2	Cnd1	REAL		R	°C/°F	Cnd1 - Cond. temp. probe (or converted value from pressure probe) circ. 1
26	2	EuP1	REAL		R	°C/°F	EuP1 - Evap. temp. probe (or converted value from pressure probe) circ. 1
28	2	dSP2	REAL		R	bar/psi	dSP2 - Discharge pressure probe circ. 2
30	2	ScP2	REAL		R	bar/psi	ScP2 - Suction pressure probe circ. 2
32	2	Cnd2	REAL		R	°C/°F	Cnd2 - Cond. temp. probe (or converted value from pressure probe) circ. 2
34	2	EuP2	REAL		R	°C/°F	EuP2 - Evap. temp. probe (or converted value from pressure probe) circ. 2
36	2	HSP1	INT		R	h	HSP1 - Source pump 1 operating hours
38	1	C045	INT		R		C045 - Refrigerant type (3 = R407C, 4 = R410a, 6 = R290, 10 = R744, 22 = R32)
40	2	HFn1	INT		R	h	HFn1 - Source fan 1 circ. 1: operating hours
42	2	HFn2	INT		R	h	HFn2 - Source fan 1 circ. 2: operating hours
46	2	SEtA	REAL		R	°C/°F	SEtA - Actual set point used for temperature control
48	2	SSH1	REAL		R	K/R	SSH1 - Suction superheat for circ. 1
50	1	Opn1	INT		R	%	Opn1 - EEV opening for circ. 1
51	2	SSH2	REAL		R	K/R	SSH2 - Suction superheat for circ. 2
53	1	Opn2	INT		R	%	Opn2 - EEV opening for circ. 2
54	2	rUSr	REAL		R	°C/°F	rUSr - Return water temperature from user
56	2	dUSr	REAL		R	°C/°F	dUSr - Delivery water temperature to user.
65	2		REAL		R	%	Fan1Req - Source fan circ. 1: inverter request
67	2		REAL		R	%	Fan2Req - Source fan circ. 2: inverter request
71	1		INT		R		UnitStatus - Unit status (0 = OFF from remote DI, 1 = OFF from keypad, 2 = OFF from scheduler, 3 = OFF from BMS, 4 = OFF from CH / HP changeover mode, 5 = OFF from alarm, 6 = Unit defrosting, 7 = Unit on, 8 = Manual mode)
90	2	rSPt	REAL		R	°C/°F	rSPt - Remote set point
92	2		REAL		R	%	PwrReq - Capacity request
96	2		REAL		R	°C/°F	SrcSetP_Circ1 - Source fan set point circ. 1
98	2		REAL		R	°C/°F	SrcSetP_Circ2 - Source fan set point circ. 2

Index	Size	Ref.	Type	Min/Max	R/W	UoM	Description
100	2	rps1	REAL		R	rps	PSD circuit 1: Actual rotor speed from the inverter
102	2	Mc1	REAL		R	A	PSD circuit 1: Current motor current [A]
104	2	MP1	REAL		R	kW	PSD circuit 1: Current motor power [kW]
106	2	Drt1	REAL		R	°C/°F	PSD circuit 1: Current drive temperature [° C]
108	1	AIHs1_1	INT		R		PSD circuit 1: Last alarm log
109	1	AIHs2_1	INT		R		PSD circuit 1: Second-to-last alarm log
110	1	AIHs3_1	INT		R		PSD circuit 1: Third-to-last alarm log
111	1	AIHs4_1	INT		R		PSD circuit 1: Fourth-to-last alarm log
114	1		INT		R		MotTyp - BLDC circ. 1 Carel Database ID
115	1		INT		R		Envelope zone circuit 1
116	2		REAL		R	°C/°F	EnvPnt_X1 - Envelope point coordinates circuit 1
118	2		REAL		R	°C/°F	EnvPnt_Y1 - Envelope point coordinates circuit 1
120	2		REAL		R	°C/°F	EnvPnt_X2 - Envelope point coordinates circuit 1
122	2		REAL		R	°C/°F	EnvPnt_Y2 - Envelope point coordinates circuit 1
124	2		REAL		R	°C/°F	EnvPnt_X3 - Envelope point coordinates circuit 1
126	2		REAL		R	°C/°F	EnvPnt_Y3 - Envelope point coordinates circuit 1
128	2		REAL		R	°C/°F	EnvPnt_X4 - Envelope point coordinates circuit 1
130	2		REAL		R	°C/°F	EnvPnt_Y4 - Envelope point coordinates circuit 1
132	2		REAL		R	°C/°F	EnvPnt_X5 - Envelope point coordinates circuit 1
134	2		REAL		R	°C/°F	EnvPnt_Y5 - Envelope point coordinates circuit 1
136	2		REAL		R	°C/°F	EnvPnt_X6 - Envelope point coordinates circuit 1
138	2		REAL		R	°C/°F	EnvPnt_Y6 - Envelope point coordinates circuit 1
140	2		REAL		R	°C/°F	EnvPnt_X7 - Envelope point coordinates circuit 1
142	2		REAL		R	°C/°F	EnvPnt_Y7 - Envelope point coordinates circuit 1
144	2		REAL		R	°C/°F	EnvPnt_X8 - Envelope point coordinates circuit 1
146	2		REAL		R	°C/°F	EnvPnt_Y8 - Envelope point coordinates circuit 1
148	1		INT		R		Envelope zone circuit 2
149	2		REAL		R	°C/°F	EnvPnt2_X1 - Envelope point coordinates circuit 2
151	2		REAL		R	°C/°F	EnvPnt2_Y1 - Envelope point coordinates circuit 2
153	2		REAL		R	°C/°F	EnvPnt2_X2 - Envelope point coordinates circuit 2
155	2		REAL		R	°C/°F	EnvPnt2_Y2 - Envelope point coordinates circuit 2
157	2		REAL		R	°C/°F	EnvPnt2_X3 - Envelope point coordinates circuit 2
159	2		REAL		R	°C/°F	EnvPnt2_Y3 - Envelope point coordinates circuit 2
161	2		REAL		R	°C/°F	EnvPnt2_X4 - Envelope point coordinates circuit 2
163	2		REAL		R	°C/°F	EnvPnt2_Y4 - Envelope point coordinates circuit 2
165	2		REAL		R	°C/°F	EnvPnt2_X5 - Envelope point coordinates circuit 2
167	2		REAL		R	°C/°F	EnvPnt2_Y5 - Envelope point coordinates circuit 2
169	2		REAL		R	°C/°F	EnvPnt2_X6 - Envelope point coordinates circuit 2
171	2		REAL		R	°C/°F	EnvPnt2_Y6 - Envelope point coordinates circuit 2
173	2		REAL		R	°C/°F	EnvPnt2_X7 - Envelope point coordinates circuit 2
175	2		REAL		R	°C/°F	EnvPnt2_Y7 - Envelope point coordinates circuit 2
177	2		REAL		R	°C/°F	EnvPnt2_X8 - Envelope point coordinates circuit 2
179	2		REAL		R	°C/°F	EnvPnt2_Y8 - Envelope point coordinates circuit 2
181	2	rps2	REAL		R	rps	PSD circuit 2: Actual rotor speed from the inverter
183	2	Mc2	REAL		R	A	PSD circuit 2: Current motor current [A]
185	2	MP2	REAL		R	kW	PSD circuit 2: Current motor power [kW]
187	2	Drt2	REAL		R	°C/°F	PSD circuit 2: Current drive temperature [° C]
189	1	AIHs1_2	INT		R		PSD circuit 2: Last alarm log
190	1	AIHs2_2	INT		R		PSD circuit 2: Second-to-last alarm log
191	1	AIHs3_2	INT		R		PSD circuit 2: Third-to-last alarm log
192	1	AIHs4_2	INT		R		PSD circuit 2: Fourth-to-last alarm log
193	1		INT		R		MotTyp2 - BLDC circ. 2 Carel database ID
213	2	AFC2	REAL		R	°C/°F	AFC2 - Condenser 2 frost protection temperature (S3 exp.)
217	2	AFC1	REAL		R	°C/°F	AFC1 - Condenser 1 frost protection temperature (S3)

Tab. 7.d

8. ALARMS AND SIGNALS

8.1 Types of alarms

The controller manages three types of alarms, depending on the reset mode:

- **A - automatic:** the alarm is reset and the device restarts automatically when the alarm condition is no longer present;
- **R - semi-automatic:** if the alarm occurs several times, reset becomes manual and an operator needs to physically restart the device.
- **M - manual:** an operator an operator needs to physically restart the device.

Alarms that require technical service are shown on the display with the flashing spanner icon.

If the spanner icon is on, it means that a device has reached the programmed operating hour threshold, and maintenance is required (the alarm code indicates which device is affected).

For some alarms, the reset mode can be configured by parameter. The configurable alarms are:

- High pressure switch
- Low pressure switch
- Frost protection alarm

User	Code	Description	Def	Min	Max	UOM
M	U081	Pressure-frost alarm reset configuration 0 = high pressure switch, low pressure switch, frost all with manual reset 1 = high pressure switch, low pressure switch, frost all with automatic reset 2 = high pressure and switch and frost with manual reset, low pressure switch with automatic reset 3 = high pressure switch with manual reset, low pressure switch, and frost with automatic reset 4 = high pressure switch and low pressure switch with manual reset, frost with automatic reset 5 = high pressure switch and low pressure switch with semi-automatic reset, frost with automatic reset 6 = high pressure switch and low pressure switch with semi-automatic reset, frost with manual reset 7 = high pressure and switch and frost with manual reset, low pressure switch with semi-automatic reset	7	0	7	-

Tab. 8.a

8.1.1 Active alarms

Note: the user terminal can only access the active alarms without password protection, or, with password protection, to the alarms relating to unit initialisation and optimisation.

Active alarms are signalled by buzzer and the Alarm button lighting up. Pressing Alarm mutes the buzzer and displays the alarm code (on the top row) and any additional information (on the bottom row). Alarm activation is recorded in the alarm log.

If the alarm is reset automatically, the Alarm button goes off, the alarm code is cleared from the list and the alarm reset event is recorded in the alarm log.

Procedure (alarm acknowledgement):

1. press Alarm: the buzzer is muted, the alarm code is shown on the display;
2. press UP/DOWN to scroll through the list of alarms;
3. when finished, press Esc and then PRG to exit.

Procedure



When an alarm is active, the buzzer sounds and the Alarm button lights up



Pressing Alarm mutes the buzzer and displays the alarm code; pressing UP/DOWN scrolls the list of any other alarms.



When reaching the end of the alarm list, "ESC" is shown: press PRG to exit the alarm list.

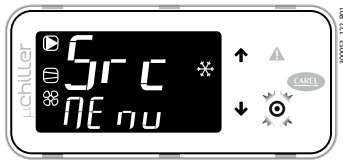

Pressing the Alarm button for more than 3 s resets the alarms: noAL indicates that there are no more active alarms. Press PRG to exit the alarm list.

A single alarm can be reset by pressing Alarm for more than 3 s. If the condition that generated the alarm is still present, the alarm will be reactivated. The alarm log can be deleted using parameter ClrH, accessible via the Service level on the terminal or APPLICA via smartphone, with BLE connection, using the specific function on the alarm page ("Service" level access). The same operations can be performed with APPLICA via smartphone, using the specific function on the alarm page (a BLE connection and "Service" level access are required).

Notes:

- deletion of the alarm log is irreversible;
- See chapter "Functions" for the alarm parameters: evaporator outlet temperature, frost protection, compressor;
- the buzzer is activated for all alarms.

8.2 Alarm list

Code	Description	Reset	Effect	Priority	Delay	No. of attempts	Evaluation period (s)
A01	Unit: no. of permanent memory writes	M	-	Fault	No	-	-
A02	Unit: permanent memory writes	M	-	Fault	No	-	-
A03	Unit: remote alarm from digital input	M	Unit shutdown	Serious, unit	No	-	-
A04	Unit: remote set point probe	A	Use standard set point	Fault	10s	-	-
A05	Unit: user return water temperature probe	A	Unit shutdown	Fault	10s	-	-
A06	Unit: user delivery water temperature probe	A	Unit shutdown	Serious, unit	10s	-	-
A08	Unit: user pump 1 overload	M	-	Fault	No	-	-
A09	Unit: user pump 2 overload	M	-	Fault	No	-	-
A10	Unit: flow switch (with user pump 1 active)	M	Unit shutdown	Serious, unit	Param. U045/U046	-	-
A11	Unit: flow switch (with user pump 2 active)	M	Unit shutdown	Serious, unit	Param. U045/U046	-	-
A12	Unit: user pump group	M	Unit shutdown	Serious, unit	No	-	-
A13	Unit: user pump 1 maintenance	A	Fault	Param.	U000	-	-
A14	Unit: user pump 2 maintenance	A	-	Fault	Param. U003	-	-
A15	Unit: high chilled water temperature	A	-	Fault	Param. U032/U033	-	-
A16	Unit: source return water/air temperature probe	A	Disable FC and Compensation (A/W units)	Fault	10s	-	-
A17	Unit: source pump 1 maintenance	A	-	Fault	Param. S000	-	-
A18	Unit: free cooling warning	M	Disable FC	Fault	Param. U032/180s	-	-
A19	Circuit 1: condensation pressure probe	A	Circuit 1 shutdown	Serious, circuit 1	10s	-	-
A20	Circuit 1: condensing temperature probe	A	Circuit 1 shutdown	Serious, circuit 1	10s	-	-
A21	Circuit 1: evaporation pressure probe	A	Circuit 1 shutdown	Serious, circuit 1	10s	-	-
A22	Circuit 1: evaporation temperature probe	A	Circuit 1 shutdown	Serious, circuit 1	10s	-	-
A23	Circuit 1: discharge temperature probe	A	Circuit 1 shutdown	Serious, circuit 1	10s	-	-
A24	Circuit 1: suction temperature probe	A	Circuit 1 shutdown	Serious, circuit 1	10s	-	-
A25	Circuit 1: high pressure switch	Param. U081.	Circuit 1 shutdown	Serious, circuit 1	No	-	-
A26	Circuit 1: high condensing pressure/temperature transducer	M	Circuit 1 shutdown	Serious, circuit 1	No	-	-
A27	Circuit 1: low pressure transducer	A (R)	Circuit 1 shutdown	Serious, circuit 1	No	3	3600
A28	Circuit 1: frost protection evaporation temperature	Param. U081	Circuit 1 shutdown	Serious, circuit 1	Param. U052	-	-
A29	Circuit 1: compressor 1 overload	Param. U081	Circuit 1 shutdown	Serious, circuit 1	Param. C049, C050	3	3600
A30	Circuit 1: compressor 2 overload	M	Comp. 1 circ. 1 shutdown	Fault, circuit 1	No	-	-
A31	Circuit 1: compressor 1 maintenance	M	Comp. 2 circ. 1 shutdown	Fault, circuit 1	No	-	-
A32	Circuit 1: compressor 2 maintenance	A	-	Fault, circuit 1	Param. C000	-	-
A33	Circuit 1: source fan maintenance	A	-	Fault, circuit 1	Param. C003	-	-

Code	Description	Reset	Effect	Priority	Delay	No. of attempts	Evaluation period (s)
A34	EVD circuit 1: LowSH	A	-	Fault, circuit 1	Param. S008	-	-
A35	EVD circuito 1: LowSH	M	Circuit 1 shutdown	Fault, circuit 1	Param. E024	-	-
A36	EVD circuit 1: LOP	A	-	Fault, circuit 1	Param. E025	-	-
A37	EVD circuit 1: MOP	A	Circuit 1 shutdown	Fault, circuit 1	Param. E026	-	-
A38	EVD circuit 1: motor error	M	Circuit 1 shutdown	Fault, circuit 1	No	-	-
A39	EVD circuit 1: emergency closing	A	-	Fault, circuit 1	No	-	-
A40	EVD circuit 1: incomplete valve closing	A	-	Fault, circuit 1	No	-	-
A41	EVD circuit 1: offline	A	Circuit 1 & 2 shutdown	Serious, circuit 1 & 2	30s	-	-
A42	Circuit 1: envelope alarm + zone alarm	A (R)	Circuit 1 shutdown	Serious, circuit 1	Param. P003	3	3600
A43	BLDC circuit 1: high pressure differential at start-up	A	BLDC 1 not enabled to start	Serious, circuit 1	5min	-	-
A44	BLDC circuit 1: failed start-up	A (R)	-	Serious, circuit 1	45s	5	3600
A45	BLDC circuit 1: low pressure differential	A	Circuit 1 shutdown	Serious, circuit 1	Param. P004	-	-
A46	BLDC circuit 1: high gas discharge temp.	M	Circuit 1 shutdown	Serious, circuit 1	No	-	-
A47	Speed drive 1: offline	A	Circuit 1 shutdown / BLDC 1	Serious, circuit 1	30s	-	-
A48	Speed drive 1: alarm + error code	A (R)	Circuit 1 shutdown / BLDC 1	Serious, circuit 1	No	3	3600
A49	Unit: circuit 2 offline	A	-	Serious, circuit 2	30s	-	-
A50	Circuit 2 unit: no. permanent memory writes	M	-	Fault	No	-	-
A51	Circuit 2 unit: permanent memory writes	M	-	Fault	No	-	-
A52	Circuit 2: condensation pressure probe	A	Circuit 2 shutdown	Serious, circuit 2	10s	-	-
A53	Circuit 2: condensing temperature probe	A	Circuit 2 shutdown	Serious, circuit 2	10s	-	-
A54	Circuit 2: evaporation pressure probe	A	Circuit 2 shutdown	Serious, circuit 2	10s	-	-
A55	Circuit 2: evaporation temperature probe	A	Circuit 2 shutdown	Serious, circuit 2	10s	-	-
A56	Circuit 2: discharge temperature probe	A	Circuit 2 shutdown	Serious, circuit 2	10s	-	-
A57	Circuit 2: suction temperature probe	A	Circuit 2 shutdown	Serious, circuit 2	10s	-	-
A58	Circuit 2: high pressure switch	Param. U081	Circuit 2 shutdown	Serious, circuit 2	No	-	-
A59	Circuit 2: high condensing pressure/temperature transducer	M	Circuit 2 shutdown	Serious, circuit 2	No	-	-
A60	Circuit 2: low pressure transducer	A (R)	Circuit 2 shutdown	Serious, circuit 2	No	3	3600
A61	Circuit 2: frost protection evaporation temperature	Param. U081	Circuit 2 shutdown	Serious, circuit 2	Param. U052	-	-
A62	Circuit 2: low pressure switch	Param. U081	Circuit 2 shutdown	Serious, circuit 2	Param. C049, C050	3	3600
A63	Circuit 2: compressor 1 overload	M	Comp. 1 circ. 2 shutdown	Fault, circuit 2	No	-	-
A64	Circuit 2: compressor 2 overload	M	Comp. 2 circ. 2 shutdown	Fault, circuit 2	No	-	-
A65	Circuit 2: compressor 1 maintenance	A	-	Fault	Param. C006	-	-
A66	Circuit 2: compressor 2 maintenance	A	-	Fault	Param. C003	-	-
A67	Circuit 2: source fan maintenance	A	-	Fault	Param. S012	-	-
A68	EVD circuit 2: LowSH	M	Circuit 2 shutdown	Serious, circuit 2	Param. E024	-	-
A69	EVD circuit 2: LOP	A	Circuit 2 shutdown	Serious, circuit 2	Param. E025	-	-
A70	EVD circuit 2: MOP	A	Circuit 2 shutdown	Serious, circuit 2	Param. E026	-	-
A71	EVD circuit 2: motor error	M	Circuit 2 shutdown	Serious, circuit 2	No	-	-
A72	EVD circuit 2: emergency closing	A	Circuit 2 shutdown	Serious, circuit 2	No	-	-
A73	EVD circuit 2: incomplete valve closing	A	Circuit 2 shutdown	Serious, circuit 2	No	-	-
A74	EVD circuit 2: offline	A	Circuit 2 shutdown	Serious, circuit 2	30s	-	-
A75	Circuit 2: envelope alarm + zone alarm	A (R)	Circuit 2 shutdown	Serious, circuit 2	Param. P003	3	3600
A76	BLDC circuit 2: high pressure differential at start-up	A	BLDC 2 not enabled to start	Serious, circuit 2	5min	-	-
A77	BLDC circuit 2: failed start-up	A (R)	-	Serious, circuit 2	45	5	3600
A78	BLDC circuit 2: low pressure differential	A	Circuit 2 shutdown	Serious, circuit 2	P004	-	-
A79	BLDC circuit 2: high gas discharge temp.	M	Circuit 2 shutdown	Serious, circuit 2	No	-	-
A80	Speeddrive circuit 2: offline	A	Comp. 1 circ. 2 shutdown	Serious, circuit 2	30s	-	-
A81	Speed drive circuit 2: alarm +code error	A (R)	Comp. 1 circ. 2 shutdown	Serious, circuit 2	No	3	3600
A85	Source delivery water temperature probe broken or disconnected - circuit 1	A	Circuit 1 shutdown	Serious, circuit 1	No	-	-
A87	Unit: EVD Evolution not compatible	A	Unit shutdown	Serious, unit	No	-	-

Tab. 8.b

9. TECHNICAL SPECIFICATIONS

Model	UCHBP* (panel models)	UCHBD* (DIN rail models)
Physical specifications		
Dimensions	See figures	See figures
Case	Polycarbonate	Polycarbonate
Assembly	panel	DIN rail
Ball pressure test temperature	125°C	125°C
Ingress protection	IP20 (rear) - IP65 (front)	IP00
Front cleaning	Use soft, non-abrasive cloth and neutral detergent or water	-
Environmental conditions		
Storage conditions	-40T85°C, <90 % RH non-condensing	-40T85°C, <90 % RH non-condensing
Operating conditions	-20T60°C, <90 % RH non-condensing	-20T60°C, <90 % RH non-condensing
Electrical specifications		
Rated power supply	24 Vac/dc (SELV or PELV power supply, Class 2)	24 Vac/dc (SELV or PELV power supply, Class 2)
Operating power supply voltage	24 Vac/dc, +10% -15%	24 Vac/dc, +10% -15%
Input frequency (AC)	50/60 Hz	50/60 Hz
Maximum current draw	600 mA rms	DIN without ExV valve driver: 600 mArms DIN with ExV valve driver: 1.25 Arms
Absorbed power for transformer sizing	15 VA	Models without valve driver: 15 VA Models with valve driver: 30 VA
Clock	precision: ± 50 ppm; min time maintenance after power off: 72 h	precision: ± 50 ppm; min time maintenance after power off: 72 h
Software class and structure	A	A
Pollution degree	3	3
Class of protection against electric shock	To be incorporated in class I or II appliances	To be incorporated in class I or II appliances
Type of action and disconnection	1.C	1.C
Rated impulse voltage	relay outputs: 4 kV; 24 V input: 0.5 kV	relay outputs: 4 kV; 24 V input: 0.5 kV
Surge immunity category	relay outputs: III; input 24V: II	relay outputs: III; input 24V: II
Control device construction	Device to be incorporated	Device to be incorporated
Terminal block	Plug-in male-female. Wire sizes: see the connector table	Plug-in male-female. Wire sizes: see the connector table
Purpose of the controller	Electrical operating control	Electrical operating control
User interface		
Buzzer	integrato	not included on the controller, built into the user terminal
Display	LED 2 rows, decimal point, and multi-function icons	LED 2 rows, decimal point, and multi-function icons
Connectivity		
NFC	Max distance 10mm, variable according to the mobile device used	Max distance 10mm, variable according to the mobile device used
Bluetooth Low Energy	Max distance 10m, variable according to the mobile device used	Max distance 10m, variable according to the mobile device used
BMS serial interface	Modbus over RS485, not opto-isolated	Modbus over RS485, not opto-isolated
FieldBUS serial interface	Modbus over RS485, not opto-isolated	Modbus over RS485, not opto-isolated
HMI interface	Modbus over RS485, not opto-isolated	Modbus over RS485, not opto-isolated
Analogue inputs (Lmax=10m)		
J2 S1, S2, S3: NTC S5: 0-5V ratiometric / 4-20 mA / NTC	NTC: resolution 0.1 °C; 10Kohm @ 25 °C, error:±1°C in the range -50T50°C, ±3°C in the range 50T90°C; 0-5 V ratiometric: error 2% fs, typical 1%; 4-20mA: error 5% fs, typical 1%	NTC: resolution 0.1 °C; 10Kohm @ 25 °C, error:±1°C in the range -50T50°C, ±3°C in the range 50T90°C; 0-5 V ratiometric: error 2% fs, typical 1%; 4-20mA: error 5% fs, typical 1%
J3 S4: 0-5 V ratiometric / 4-20 mA / NTC S6: 0-5 V ratiometric / 0-10V / 4-20 mA / NTC	0-5 V ratiometric: error 2% fs, typical 1%; 4-20mA: error 5% fs, typical 1%; 0-10 V: error 2% fs, typical 1%	0-5 V ratiometric: error 2% fs, typical 1%; 4-20mA: error 5% fs, typical 1%; 0-10 V: error 2% fs, typical 1%
J9 S7: NTC (DIN version only)	-	NTC: resolution 0.1 °C; 10Kohm @ 25 °C, error:±1°C in the range -50T50°C, ±3°C in the range 50T90°C;
Digital inputs (Lmax=10m)		
Model	UCHBP* (panel models)	UCHBD* (DIN rail models)
J2	ID1(*)	Voltage-free contact, not optically-isolated, typical closing current 6 mA, voltage with contact open 13 V, max contact resistance 50Ω (*) Fast digital input: 0-2 kHz; error 2% fs
J2	ID2	
J3	ID3(*), ID4, ID5,	
J9	ID6 - avail. only on DIN vers	

Model	UCHBP* (panel models)	UCHBD* (DIN rail models)
Valve output		
J14	Available only on DIN version	CAREL E*V unipolar valve power supply: 13 Vdc, min winding resistance 40 Ω
Analogue outputs (Lmax=10m)		
J14	Y1, Y2	0...10 Vdc: 10 mA max
Digital outputs (Lmax=10m)		
<p>Note: the sum of current draw on NO1, NO2, NO3 and NO4 must not exceed 8 A</p>		
J6	NO1(5A), NO2(5A), NO3(5A), NO4(5A)	5A: EN60730: 5A resistive, 250Vac, 50k cycles; 4(1), 230Vac, 100k cycles; 3 (1), 230Vac, 100k cycles
J7	NO5(5A)	UL60730: 5A resistive, 250Vac, 30k cycles; 1FLA, 6LRA, 250Vac, 30k cycles; Pilot Duty C300, 30k cycles
J11	NO6(5A) - only for DIN	250Vac, 30k cycles; Pilot Duty C300, 30k cycles
Emergency powersupply		
J10: Ultracap module (optional, available only on DIN version)	-	13 Vdc ±10%
Probe and terminal powersupply (Lmax=10m)		
5V	5 Vdc ± 2% to power the 0 to 5 V ratiometric probes. Maximum current delivered: 35 mA protected against short-circuits	5 Vdc ± 2% to power the 0 to 5 V ratiometric probes. Maximum current delivered: 35 mA protected against short-circuits
+V	8-11 V to power the 4-20 mA current probes. Maximum current delivered: 80 mA protected against short-circuits	8-11 V to power the 4-20 mA current probes. Maximum current delivered: 80 mA protected against short-circuits
VL	Not used	Not used
J8	User terminal power supply	User terminal power supply
Serialports		
BMS	<ul style="list-style-type: none"> • Integrated • Protocol: Modbus 	<ul style="list-style-type: none"> • Integrated • Protocol: Modbus
Lmax=500 m, shielded cable (RS485 1½ twisted pair) (1)	<ul style="list-style-type: none"> • HW driver: asynchronous half duplex RS 485 Circuit 2 • Not optically-isolated • 3-pin plug-in connector, 3.81 mm pitch • Max data rate: 115200 bit/s • Maximum number of connectable devices: 16 	<ul style="list-style-type: none"> • HW driver: asynchronous half duplex RS 485 Circuit 2 • Not optically-isolated • 3-pin plug-in connector, 3.81 mm pitch • Max data rate: 115200 bit/s • Maximum number of connectable devices: 16
FieldBus	<ul style="list-style-type: none"> • Integrated • HW driver: asynchronous half duplex RS 485 Circuit 1. 	<ul style="list-style-type: none"> • Integrated • HW driver: asynchronous half duplex RS 485 Circuit 1.
J5: Lmax=10 m, shielded cable (RS485 1½ twisted pair) (1)	<ul style="list-style-type: none"> • Typical reception resistance 96 kohms, equal to 1/8 of unit load, i.e. 1/256 of maximum load applicable on the line • Not optically-isolated • Max data rate: 19200 bit/s • Maximum number of connectable devices: 16 • Protocol: Modbus RTU 	<ul style="list-style-type: none"> • Typical reception resistance 96 kohms, equal to 1/8 of unit load, i.e. 1/256 of maximum load applicable on the line • Not optically-isolated • Max data rate: 19200 bit/s • Maximum number of connectable devices: 16 • Protocol: Modbus RTU
Cable lengths		
Analogue inputs/outputs, digital inputs/outputs, probe power	<10m (*) (*) in the panel version, if using the +13 V power supply in domestic environments, the maximum cable length is 2 m.	
Valve	< 2 m, < 9 m with shielded cable	< 2 m, < 9 m with shielded cable
BMS and Fieldbus serial cables	<500m with shielded cable	<500m with shielded cable
Conformity		
Electrical safety	EN/UL 60730-1, EN/UL 60335-1	EN/UL 60730-1, EN/UL 60335-1
Electromagnetic compatibility	EN 61000-6-1, EN 61000-6-2, EN 61000-6-3, EN 61000-6-4	EN 61000-6-1, EN 61000-6-2, EN 61000-6-3, EN 61000-6-4
Applications with flammable refrigerant gases	EN/UL 60079-15, EN/UL 60335-2-34, EN/UL 60335-2-40, EN/UL 60335-2-89	EN/UL 60079-15, EN/UL 60335-2-34, EN/UL 60335-2-40, EN/UL 60335-2-89
Wireless compliance	RED, FCC, IC	RED, FCC, IC

Tab. 9.a

Note: (1) it is recommended to use a BELDEN 8761 cable (AWG 22).

9.1 Connector/cable table

Ref.	Description	Wiring terminals	Wire cross-section (mm ²)	Lmax (m)
J1	Controller power supply	Panel model: plug-in terminal, screw, 2-pin, pitch 5.08 DIN rail model: plug-in terminal, screw, 2-pin, pitch 5.08	0.5...1.5 0.21...3.31	10 10
J2	Inputs S1, S2, S3, S5, ID1, ID2; outputs Y2, Y2	10-pin Microfit crimp connector	0.05...0.52	10
J3	Inputs S4, S6, ID3, ID4, ID5	8-pin Microfit crimp connector	0.05...0.52	10
J4	BMS	Plug-in screw terminal, 3-pin, pitch 3.81	0.081...1.31	500
J5	Fbus	Plug-in screw terminal, 3-pin, pitch 3.81	0.081...1.31	10
J6	Outputs NO1, NO2, NO3, NO4	6-pin Microfit crimp connector	0.5...1.31	10
J7	Output NO5	3-pin Microfit crimp connector	0.5...1.31	10
J8	Unit terminal	Connection cable P/N: ACS00CB000010 (L=3m)-/20 (L=1.5m)	0.13	2 (*)
J9	Inputs S7, ID6	4-pin Microfit crimp connector	0.05...0.52	10
J10	Ultracap	3-pin JST connector	0.13	2
J11	Output NO6	3-pin Microfit crimp connector	0.5...1.31	10
J14	Unipolar ExV valve	CAREL ExV unipolar valve connector, pre-wired	-	2, 6 with shielded cable

Tab. 9.b

(*) device to be incorporated.

10. RELEASE NOTES

The information and functions described in this manual refer to μ Chiller versions 3.1.4 or higher.

CAREL

CAREL INDUSTRIES - Headquarters

Via dell'Industria, 11 - 35020 Brugine - Padova (Italy)
Tel. (+39) 049.9716611 - Fax (+39) 049.9716600
e-mail: carel@carel.com - www.carel.com

µchiller +0300053EN rel. 2.2 - 14.12.2021