

Installation guide

ELIMINATOR® Hermetic filter drier Type DMT

023R9546

023R9546

Refrigerant R744 (CO2)

Maximum working pressure

PS/MWP: 140 bar/2030 psig

Refrigerant temperature



T_{min.}: -40 °C / -40 °F

T_{max.}: 100 °C / 212 °F

Flare / flare o-ring / flare NPT
copper plated solder versions

Connection: All sizes

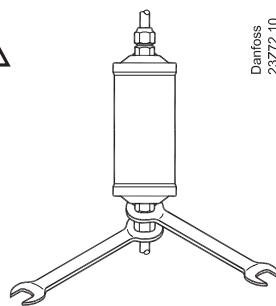
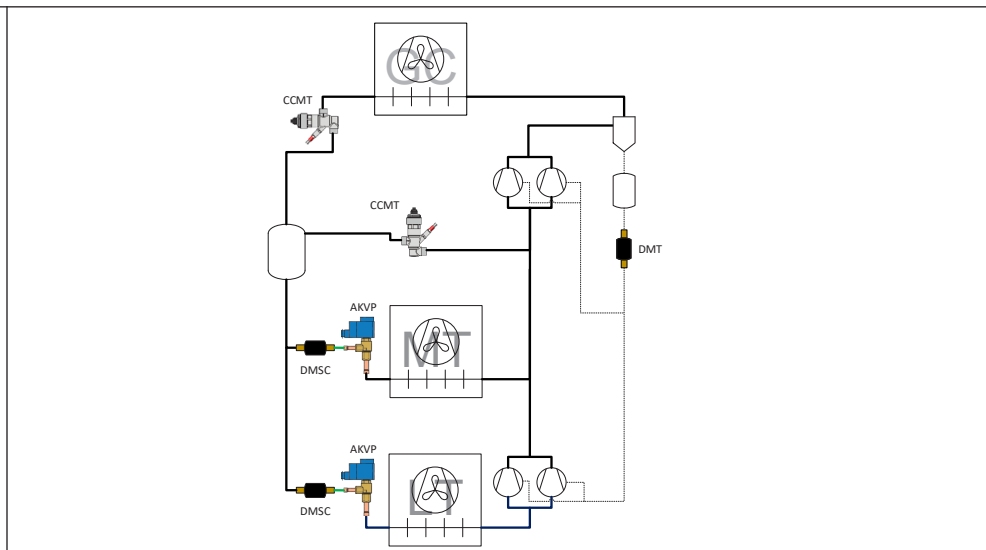
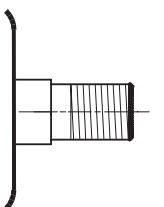
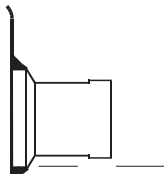
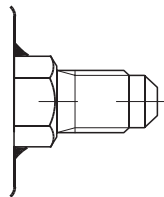

Danfoss
23Z72.10

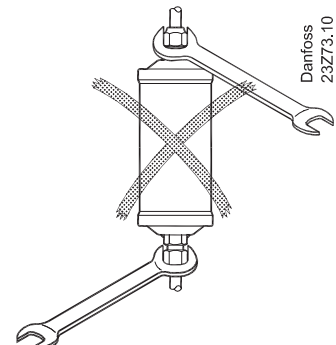

Danfoss
23Z73.10



Keep flames away
from body

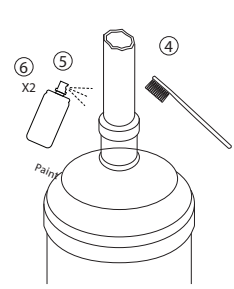
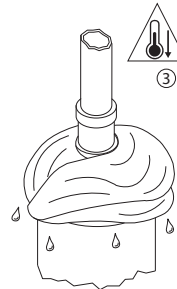
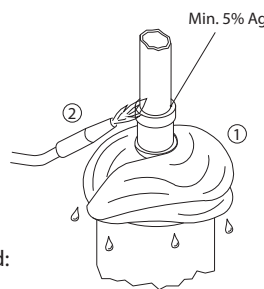

Danfoss
23Z73.10

Customer best practice will still be needed:

1. Use wet wrap when installing.
2. Braze the joints.
3. Let them cool down.
4. Clean the welding area after the installation (remove remaining flux with a brush).
This is an important operation and needs to be done with great care to remove all remaining flux.
5. Paint / Anti-corrosive needs to cover all open steel parts, areas where the black original paint has been burnt due to brazing and at least 3 cm approx of the copper.
6. Paint the joints twice.

Any information, including, but not limited to information on selection of product, its application or use, product design, weight, dimensions, capacity or any other technical data in product manuals, catalogues descriptions, advertisements, etc. and whether made available in writing, orally, electronically, online or via download, shall be considered informative, and is only binding if and to the extent, explicit reference is made in a quotation or order confirmation. Danfoss cannot accept any responsibility for possible errors in catalogues, brochures, videos and other material. Danfoss reserves the right to alter its products without notice. This also applies to products ordered but not delivered provided that such alterations can be made without changes to form, fit or function of the product.

All trademarks in this material are property of Danfoss A/S or Danfoss group companies. Danfoss and the Danfoss logo are trademarks of Danfoss A/S. All rights reserved.