

Millions of reasons to choose the best

Millions of Danfoss AB-QM™ Pressure Independent Control Valves (PICV's) are installed worldwide because they provide perfect flow control & hydronic balance, increasing energy savings by 20-50%.

**3 years
payback time**

Case studies prove that investing in Danfoss PICV's pays itself back in less than 3 years.

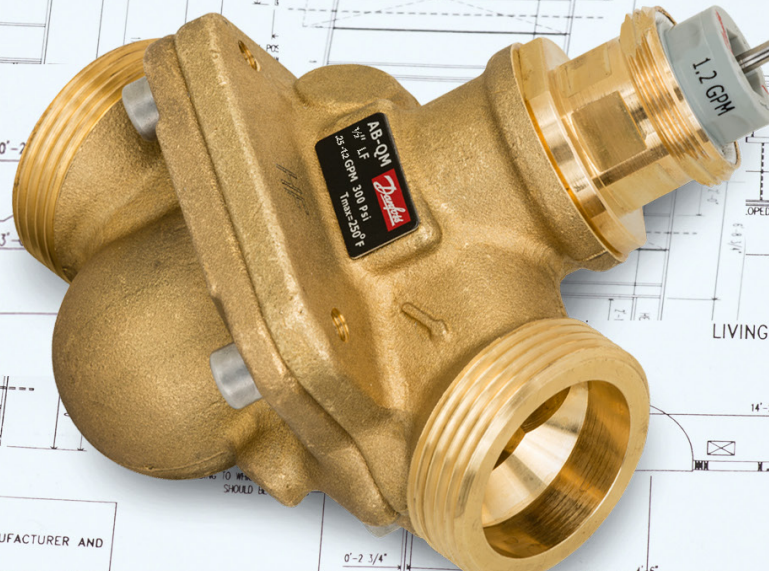

NOTE:
CONFIRM R.O. SIZES WITH WINDOW MANUFACTURER AND
ADJUST WALL FRAMING ACCORDINGLY.

Energy Demands? | Comfort Problems? | Maintenance Concerns?

www.ABQMvalves.com



NO MATTER THE INSTALLATION EXPERIENCE **SUBSTANTIAL ENERGY SAVINGS!**

From newly-built to renovations – Danfoss AB-QM™ is made for your business

Despite all the innovations in the field of installation, it is still a challenge to balance and control HVAC systems without pressure independent technology. The Danfoss AB-QM™ Pressure Independent Control Valve (PICV) will help save time during implementation, decrease maintenance and save energy whether you're looking for an energy saving solution during renovation or designing for a new building.

The easy choice

Danfoss AB-QM™ pressure independent temperature control valve cuts energy consumption from HVAC by 20-50%.



I ALREADY USE PICV'S – **WHY DANFOSS?**

There are many types of PICV's – and then there is the AB-QM™

Danfoss is the market leader in pressure independent control technology, with vast experience producing reliable and precise automatic control solutions. Independent research institutes determined that the AB-QM™ provides the best control performance compared to other pressure independent control valves on the market. Extended product range of valve sizes and matching actuators offers perfection in control, even at low flows.

To make your job easier, our experienced sales and technical support staff will recommend the best setup for your application and provide you with unsurpassed service.

Your benefits:

- **One valve does it all** (Dynamic balancing and control valve all in one)
- **Third party testing of AB-QM™ indicates accuracies of ± 5% of setpoint**
- **Compact Design**
- **100% Valve Authority**
- **Broad range of products with unique self-calibrating actuators**
- **Experienced customer service and technical support staff**





I USE CONVENTIONAL SOLUTIONS – WHY CHANGE?

The future is now

As opposed to conventional three-way or systems with manual balancing valves, the Danfoss AB-QM™ simplifies your system and removes the need for multiple devices. That's because the AB-QM™ is a compact, partial flow balancing valve and temperature control valve in one! As a combined assembly, the AB-QM™ leads to reduced commissioning and installation time. The required flow is simply set as a percentage of the valve's maximum flow and adjusted in the field.

Your benefits:

- **100% Valve Authority = 100% Flow Stability at Partial Loads**
- **Use fewer products to balance system**
- **Less commissioning and shorter installation time**
- **Maintenance Minimized**



I HAVE AN EXISTING INSTALLATION – WHY UPGRADE?

AB-QM™ is perfect for improving performance on your current HVAC system

From experience we know that our customers are challenged with balancing and control issues in their existing HVAC installations. Equipping your system with AB-QM™ will help you solve them. Since AB-QM™ leads to energy savings, the potential return on investment is less than three years.

Your benefits:

- **AB-QM™ puts your system back into proper balance**
- **Improved balance/control & substantial energy savings (\$\$\$)**
- **Minimized horsepower required by pump**
- **Chillers operate at designed capacities**
- **Improved Indoor comfort**
- **High ROI with potential payback time in less than 3 years**

PERFECT CONTROL AND BALANCE WITH AB-QM™

Danfoss developed the AB-QM™, a pressure independent temperature control valve. The valve, combined with a Danfoss actuator, optimizes your system and puts it back into proper balance in a cost-effective manner, and because the AB-QM assures that the flows required for heating or cooling match the loads perfect indoor climate is achieved. These system improvements lead to energy savings.

Peace of mind

More than 3 million AB-QM™ valves installed really says it all. This valve offers more than just control and balance in HVAC systems. It will save you time when installing, calculating and commissioning. Your customers will benefit from enhanced comfort.

Your benefits:

- **Lower costs and higher energy efficiency**
- **Better indoor comfort as flows always match load requirements**



FULL RANGE OF SIZES 1/2" TO 10"

Danfoss Knows that Size Matters!

Danfoss understands that size matters and is the only manufacturer of PICV's on the market with available sizes ranging from 1/2" to 10". To perfectly compliment all sizes of our AB-QM™ valves, Danfoss has developed a unique collection of low voltage actuators. This synergistic combination of AB-QM™ valves and actuators can handle any size application - from the smallest air handling units to the largest buildings in the world.



Your benefits:

- **Compact design** (great for small spaces such as fan coil units, VAV boxes, retrofits, etc.)
- **Extensive PICV sizes and actuator choices**
- **Extensive flow ranges; .25 GPM (1/2" Low Flow) to 1629 GPM (10" High Flow)**

AB-QM™ HELPS YOU GO GREEN



With AB-QM™ valves, we have saved a significant amount of electricity (14-15%) simply by regulating the chilled water pump flow via variable speed drives at required rate only. Not only does this benefit us in terms of financial costs, it also supports the company's long term sustainable environment policies."

Edward Kway – Head of Engineering
Fraser Centrepoint



WE'VE DONE THE MATH SO YOU CAN FOCUS ON **ENERGY SAVINGS & COST REDUCTION**

Controlling indoor temperatures is the central function of a HVAC installation. Therefore control valves are crucial and they need to be accurately sized to achieve optimal working conditions. The AB-QM™ precision & simple setting eliminates the need for sizing calculations and mistakes.

With AB-QM™ there is no need to calculate the Cv value of the valve anymore because if the required flow is within the setting range of the valve, it can be applied. This also means greater flexibility because several different pipe sizes, of AB-QM™ can be used to achieve

the same flow. The simple setting procedure of the AB-QM™ makes late changes in the design or subsequent system adjustments easy to implement.

The AB-QM™ has a compact and unique design that ensures 100% authority with all settings and all differential pressures and therefore makes authority calculations unnecessary. Having a 100% valve authority increases the control quality and precision – even at low flow requirements. This means increased comfort in the overall building, as well as energy savings.

Sizing

You will only need to know the flow, when sizing the AB-QM™ valve. Compared to properly sizing a traditional balancing valve: where you still need to know the required flow, the pump head and the resistance in the rest of the installation. AB-QM will save installers a lot of time.

Your benefits:

- **Easy setting and sizing**
- **100% Valve authority & perfect control**

HOW DOES IT WORK?

The working principle is as simple as it is effective. The AB-QM™ consists of two different parts: the control valve (orange) and the differential pressure controller (blue). The integrated membrane of the pressure controller maintains a constant differential pressure across the valve. The flow through a valve is determined by the Cv value and the differential pressure across the valve. As long as the

minimum differential pressure across the valve body is met, a constant flow rate is maintained preventing overflow and the authority of the AB-QM™ to control the flow is ensured.

pushed down and close the pressure controller (2). If the differential pressure decreases, the membrane will instantly move up again (3).

Your benefits:

- Constant Δp across the valve portion of the AB-QM™ results in accurate flow limitation and 100% authority.
- Double shut off for Class IV (**No leakage certification**).

Figures 1-3

In the illustrations you can see the membrane in action. If the differential pressure across the valve increases, the membrane will immediately be

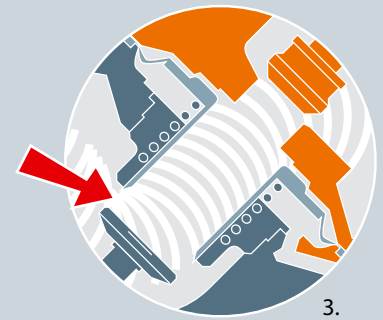
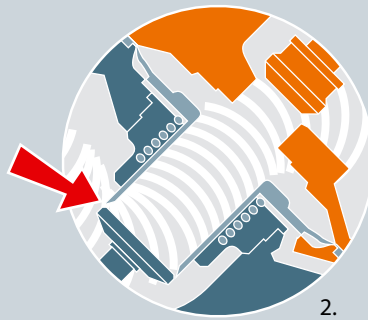
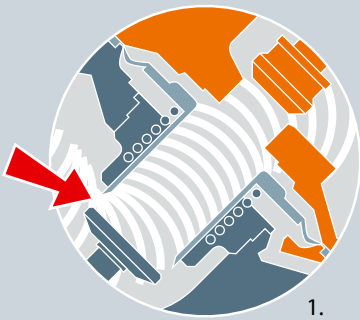

APPLICATIONS

The Danfoss AB-QM™ is the obvious control valve choice for water based units, such as Air Handling Units, Fan-coil units, chilled ceiling beams or radiator systems. The AB-QM™ combined with a Danfoss actuator, ensures the required flow in every unit and maintains hydronic balance in the entire system. AB-QM™ is successfully applied in offices, hotels, hospitals, airport terminals, and in buildings where accurate temperature control is extremely important, such as in laboratories, medical facilities or food processing areas.

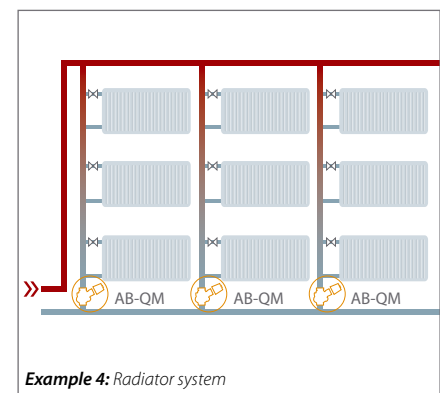
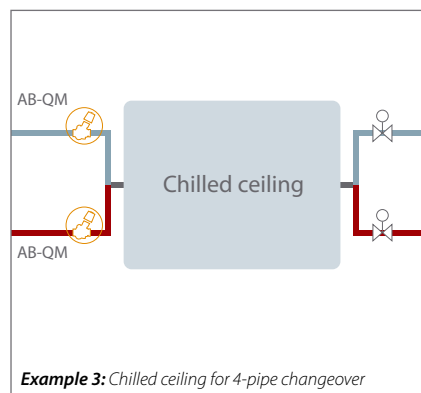
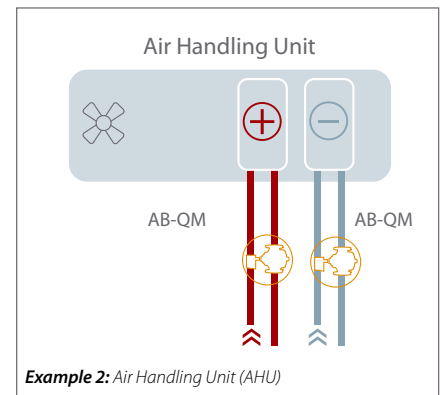
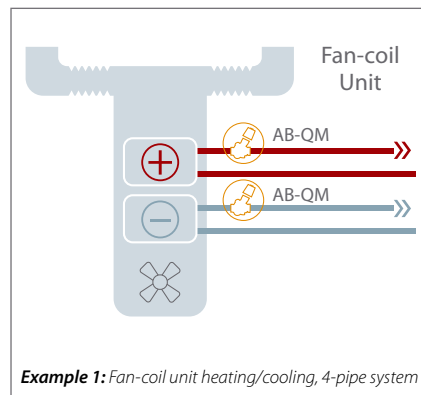

THE PERFECT MATCH

Danfoss offers a wide range of low voltage AB-QM™ actuators that are perfectly matched to any application. AB-QM™ actuators provide various control strategies; 3 point Floating, On/Off, and Proportional/Modulating.

Our AB-QM™ actuators have advanced travel-length detection (self-comissioning) to ensure 100% match of the input signal range to the valve travel.

A selection from our extensive range of actuators:



TWA-Z and ABN A5

Thermal wax actuator On/Off 24 NC/NO.

ABNM A5 LOG/LIN

Modulating thermal actuator 0-10V.

AME/V 110/120NLX

Actuator for 3-point or modulating (0-10V) control.

AME 435QM

Actuator for modulating (0-10V) control.

AME 55QM

Actuator for 3-point or modulating (0-10V) control.

AME 85QM

Actuator for 3-point or modulating (0-10V) control.



Learn more on our website: www.ABQMvalves.com

PROJECT REFERENCES

The AB-QM™ PICV was introduced several years ago and has enjoyed success, which is evident from the list of references and successful case stories around the globe.

Oswega High School

Location: Oswego, IL USA

Products: 125 AB-QM™ Valves (½" to 6") with AME110NL Actuators installed on Air Handling Units (AHUs), Variable Air Volume (VAV), & Fan Coil Units (FCU) throughout the facility.



Rochester Institute of Technology

Location: Rochester, NY USA

Products: 200 AB-QM™ Valves installed on chilled beams along with AME 13/25/55 Actuators & AM-PBU25.

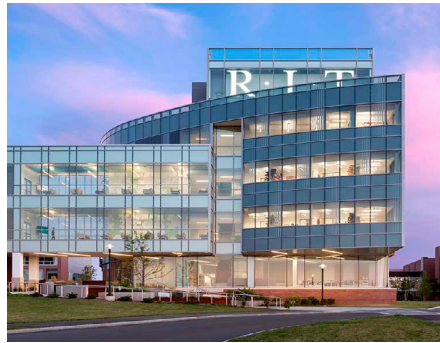

U.S. General Service Administration (GSA) Headquarters

Location: Washington, DC USA

Products: 1200 AB-QM™ Valves (½" to 3") installed on heating and cooling pipes, FCU, AHU, & VAVs.



Toledo Hospital

Location: Toledo, OH USA

Products: 30 AB-QM™ Valves (½") with AME110NL Actuators installed on heating and cooling and FCUs.



Waldorf Astoria Hotel

Location: Amsterdam, Netherlands

Products: 214 AB-QM™ Valves (¾"-2½") with AME435/AME110NL Actuators installed on FCU & AHUs.



Prime Tower

Location: Zurich, Switzerland

Products: 6150 AB-QM™ Valves (½" to 6") with AME actuators installed on 36 floors throughout the tallest building in Switzerland.



Danfoss · North America · Heating Segment · 11655 Crossroads Cir. Baltimore, MD 21220
Telephone: 1.866.375.4822 · E-mail: heatingcustomerservice@danfoss.com · www.ABQMvalves.com

Danfoss can accept no responsibility for possible errors in catalogues, brochures, and other printed material. Danfoss reserves the right to alter its products without notice. This also applies to products already on order provided that such alterations can be made without subsequential changes being necessary in specifications already agreed. All trademarks in this material are property of the respective companies. Danfoss and the Danfoss logotype are trademarks of Danfoss A/S. All rights reserved.