

Technical Information

Bourdon Type Gauges MR-Types

Part No. (Different part numbers)

Applications

- For measuring points with high dynamic pressure pulsations or vibrations.
- Can be used for all common refrigerants. Special dials with other temperature-scales available on request.
- For gaseous and liquid media that are not highly viscous or crystallizing and will not attack copper alloy parts.

Special Features

- Vibration and shock resistant
- Especially sturd design
- Approved by German Lloyd and Gosstandart

Technical data

Design	EN 837-1
Nominal size in mm	63
Accuracy class	1.6
Pressure limitation	Steady: 3/4 x full scale value Fluctuating: 2/3 x full scale value Short time: full scale value
Operating temperature	Ambient: -20°C to +60 °C Medium: +60 °C maximum
Temperature effect	When the temperature of the measuring system deviates from the reference temperature (+20 °C): max. ±0.4 %/10 K of the span
Ingress protection	IP 65 per EN 60529 / IEC 60529
Process connection	¼ SAE
Pressure element	< 60 bar: Cu-alloy, C-type ≥ 60 bar: Cu-alloy, helical type
Movement	Cu-alloy
Dial	Plastic ABS, white, with pointer stop pin
Pointer	Plastic, black

Window	Plastic, crystal-clear
Case	Natural finish stainless steel, with pressure relief at case circumference, 12 o'clock.
Bezel ring	Crimp ring, glossy finish stainless steel, triangular bezel.
Liquid filling	Glycerine

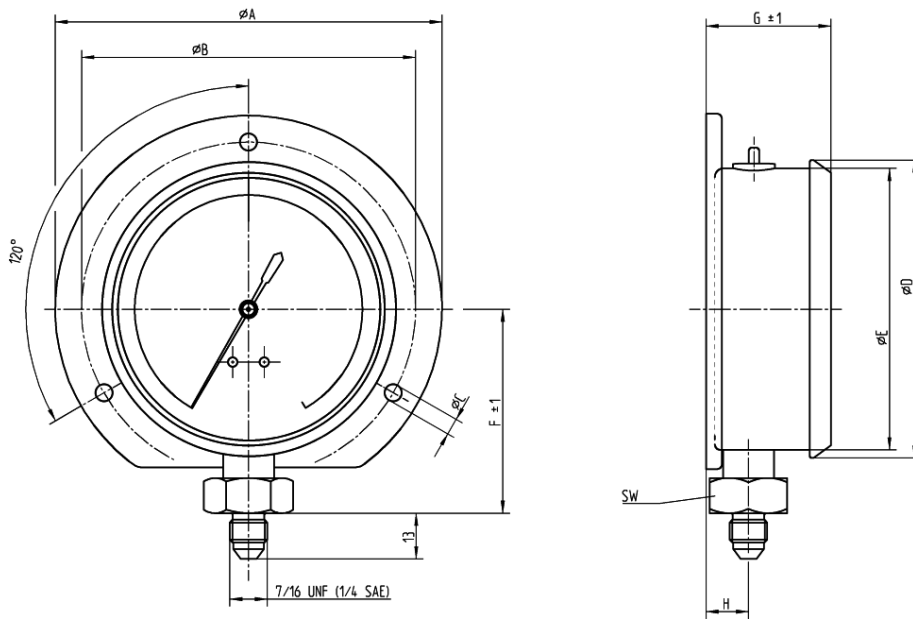

Typ	ØA	ØB	ØC	ØD	ØE	F	G	H	SW
MR-206 / 306	85	75	3.6	68	62	41	32.5	13.5	14
MR-406 / 506	110	95	4.8	85	80	58	35	11.5	17
MR-606 / 706	135	116	6.5	107	100	68	37	14.5	17

REFCO Manufacturing Ltd.
 Industriestrasse 11
 CH-6285 Hitzkirch
 Tel.: +41 41 919 72 82
 Fax: +41 41 919 72 83
 Email: info@refco.ch
www.refco.ch

Date 13.05.2022 / Ri